

Device/PLC Connection Manuals



About the Device/PLC Connection Manuals

Prior to reading these manuals and setting up your device, be sure to read the "Important: Prior to reading the Device/PLC Connection manual" information. Also, be sure to download the "Preface for Trademark Rights, List of Units Supported, How to Read Manuals and Documentation Conventions" PDF file. Furthermore, be sure to keep all manual-related data in a safe, easy-to-find location.



5.5 Yokogawa Electric

5.5.1 System Structure

The following describes the system structure for connecting the GP to Yokogawa Electric PLCs.

Reference The Cable Diagrams mentioned in the following tables are listed in the section titled "5.5.2 Cable Diagrams".

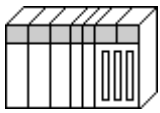
FACTORY ACE Series/FA-M3 (using Link I/F)

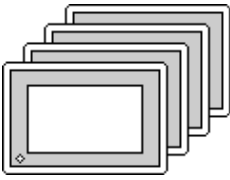
CPU	Link I/F	Cable Diagram	GP
	PC Link Unit 		
F3SP20-0N, F3SP21-0N, F3SP25-2N, F3SP28-3N, F3SP30-0N, F3SP35-5N, F3SP38-6N, F3SP53-4H, F3SP58-6H, F3SP36-3N, F3SP28-3S, F3SP38-6S, F3SP53-4S, F3SP58-6S, F3SP59-7S	F3LC11-2N	With n:1 transmission *1 (Cable Diagram 1) With n:m transmission *1 (Cable Diagram 2)	GP Series

* 1 The diagram below shows the system configuration recommended to allow n:m data transmission, using the host link protocol, between the Yokogawa Electric PLC [FA-M3] (or equipment supporting the same protocol - m units), and the GP (n units).

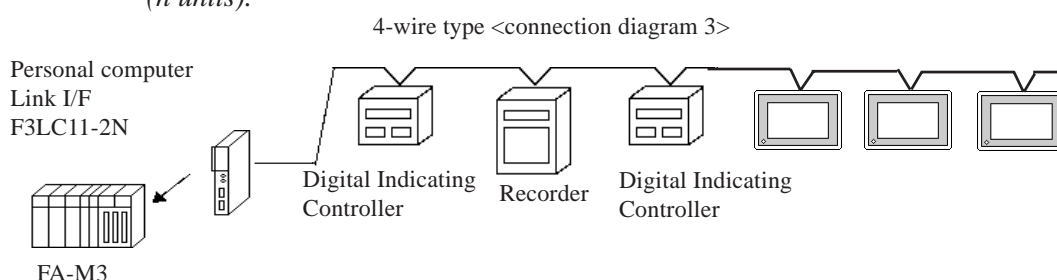

- Hereafter, equipment (i.e. a digital Indicating <UT37/38/2000> or recorder <mR series>) which supports either the FA-M3 or an identical protocol, will be called PA equipment.
- According to this PLC's design specifications, PA equipment can utilize from No. 1 through No.16 device positions, however, Nos. 17 and above cannot be used.

5.5.2 Cable Diagrams

The cable lines illustrated below and the cable lines recommended by Yokogawa Electric may differ, however, using these cables for your PLC operations will not cause any problems.

Cable Diagram 1

- When using Digital's RS-422 connector terminal adapter GP070-CN10-O

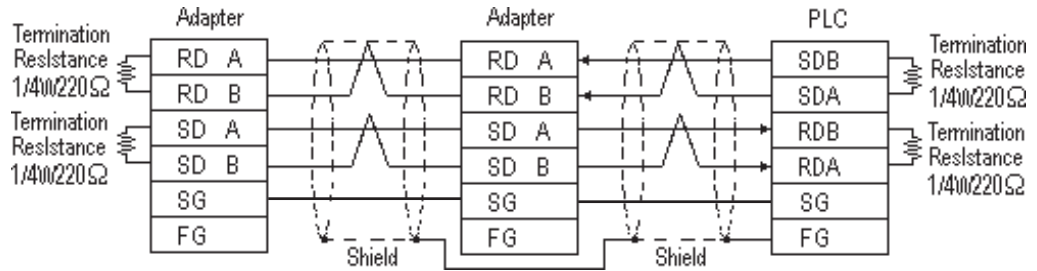

- When using Digital's Multi-link Cable, GP230-IS12-O

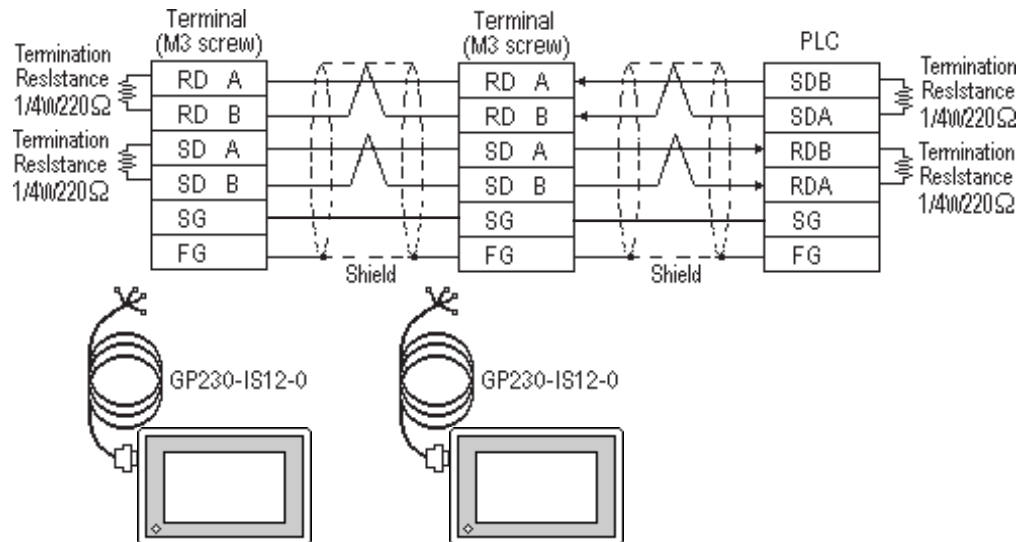

Ground your PLC's FG terminal according to your country's applicable standard. For details, refer to the corresponding PLC manual.



- **Pull out a small amount of the Transfer Cable's shield, make a wire out of it and connect it to the PLC's FG terminal.**
- **The GP230-IS12-O Cable FG terminal is not connected to the GP's FG.**
- **Connect a Termination Resistor at both ends of the cable.**
- **As a general rule, connect the PLC on one end of the circuit.**

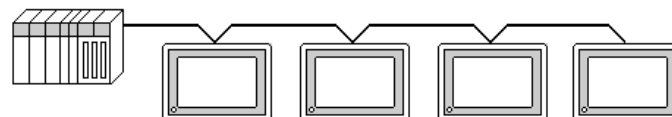



When making your own cable connections, we recommend using Hitachi Densen's CO-SPEV-SB (A) 3P* 0.5SQ.

The cable connection lines are as illustrated below. The cables between the GP and the terminals should be less than 10m.

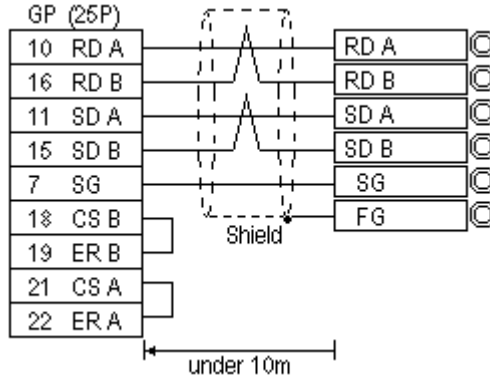

Cable Diagram 2

The following diagram is an example of the connection between the GP and PLC, showing both sides/ends of the wiring. Be sure to install terminating resistors as shown, on both side of the equipment.

- When using Digital's RS-422 connector terminal adapter GP070-CN10-O

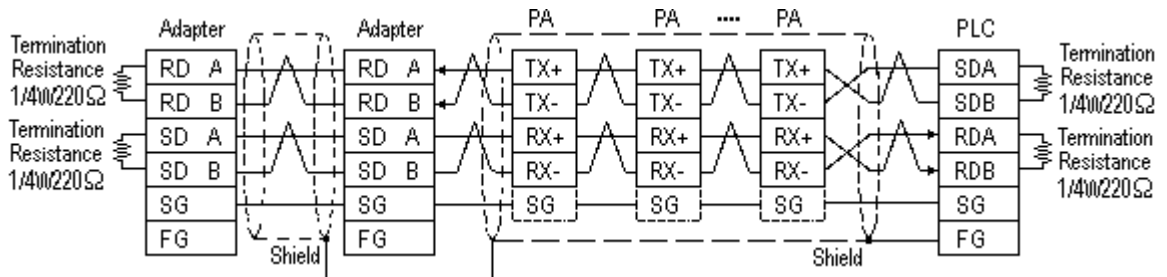

- * If a PA unit uses an SG wire, be sure to connect it.
- * If the PA unit does not have an SG wire, be sure to connect the GP's SG wire to the PLC's SG wire.

- When using Digital's Multi-link Cable, GP230-IS12-O

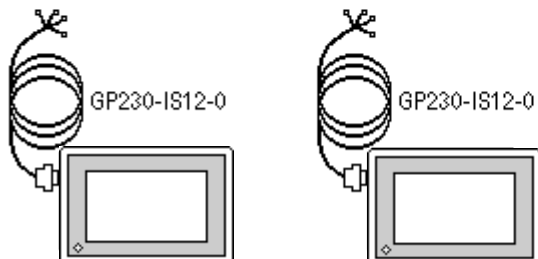
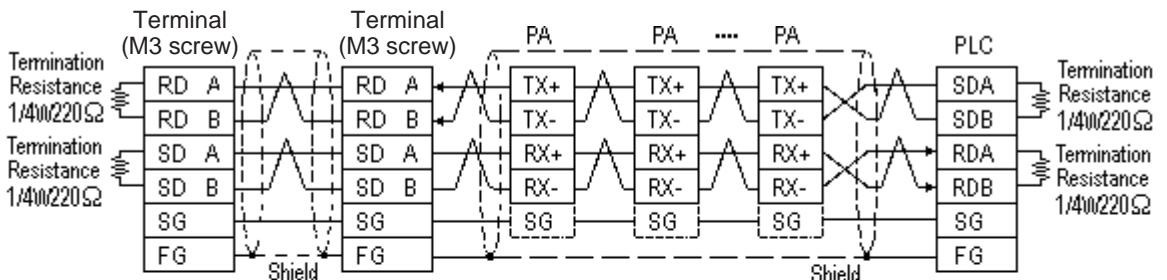

- * If a PA unit uses an SG wire, be sure to connect it.
- * If the PA unit does not have an SG wire, be sure to connect the GP's SG wire to the PLC's SG wire.



- **The naming/labeling of the A and B pins on the GP side is the reverse of the PLC side.**
- **Set up the personal computer Link I/Fs, using station(s) No. 1 to No.32.**
- **Set up unique numbers for each piece of PA equipment to be connected to the GP. If the same number is used by 2 or more pieces of PA equipment, errors will occur.**
- **Be sure that the data transmission settings between each GP (n units) and its related PA equipment (m units) are identical.**
- **Ground your PLC's FG terminal according to your country's applicable standard.**
- **Pull out a small amount of the Transfer Cable's shield, make a wire out of it and connect it to the PLC's FG terminal.**
- **The GP230-IS12-O Cable FG terminal is not connected to the GP's FG.**
- **Be aware the A and B signals of the GP and PLC are opposite to each other.**
- **Place a Termination Resistor at either end of the cable.**
- **As a general rule, connect the PLC on either end of the circuit.**



When making your own cable connections, we recommend using Hitachi Densen's CO-SPEV-SB (A) 3P* 0.5SQ.

The cable connection lines are as illustrated below. The cables between the GP and the terminals should be less than 10m.

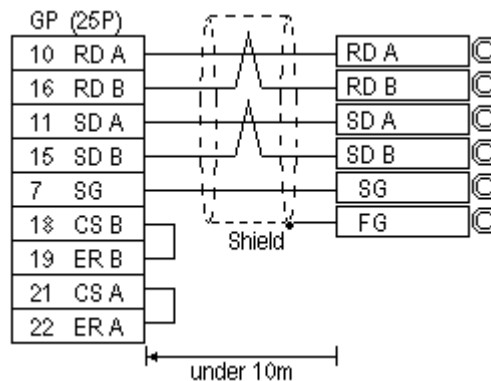

5.5.3 Supported Devices

The following describes the range of devices supported by the GP.

■ **FA-M3** (n:1 communication)

 Setup System Area or Communication Information's Storing Address here.

Device	Bit Address	Word Address	Particulars
Input Relay	X00201 ~ X71661	X00201 ~ X71649	÷16+1 *1,2
Output Relay	Y00201 ~ Y71664	Y00201 ~ Y71649	÷16+1 *1
Internal Relay	I00001 ~ I65535	I00001 ~ I65521	÷16+1
Joint Relay	E0001 ~ E4096	E0001 ~ E4081	÷16+1
Special Relay	M0001 ~ M9984	M0001 ~ M9969	÷16+1
Link Relay	L00001 ~ L78192	L00001 ~ L78177	÷16+1
Timer (contact)	T0001 ~ T3072	---	*2
Counter (contact)	C0001 ~ C3072	---	*2
Timer (current value)	---	TP0001 ~ TP3072	
Timer (setup value)	---	TS0001 ~ TS3072	*2
Counter (current value)	---	CP0001 ~ CP3072	
Counter (setup value)	---	CS0001 ~ CS3072	*2
Data Register	---	D00001 ~ D65535	Bit 5
File Register	---	B00001 ~ B65536	Bit 5 *3,4
		B065537 ~ B131072	
		B131073 ~ B196608	
		B196609 ~ B262144	
Joint Register	---	R0001 ~ R4096	Bit 5
Special Register	---	Z001 ~ Z1024	Bit 5
Link Register	---	W00001 ~ W74096	Bit 5 *5

L/H

*1 The value of the terminal number (bit), 01~49, of the last two digits for the Input Relay and

Output Relay can only be a multiple of 16 + 1.

E.g. For X00201

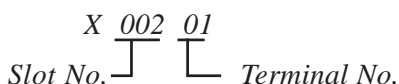

*2 Cannot perform data write.

(Continued on next page)

*3 File registers are each 65,535 words on your GP application.

You cannot extend over more than a single data "block" when performing the following features.

Be sure to set these features' settings so they are within a single data block.

- 1) "a-tag " settings
- 2) Performing Block read/write from Pro-Server
- 3) Designating the "Convert from" and "Conver to" address for the "Address Conversion" features

*4 When using a PC Link module, only Link Register up to B99999 can be used.

*5 A total of up to 4,096 link registers can be used.



- Write the CPU Number (1~4) in front of the device name.

E.g. For Internal Relay I0001, CPU #3:

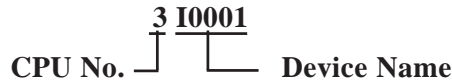

- The range of device that can be used will vary depending on the type of PLC.
For detailed information refer to the Yokogawa's Sequence CPU manual.

■ FA-M3 (n:m communication)

Setup System Area or Communication Information's Storing Address here.

Device	Bit Address	Word Address	Particulars
Input Relay	X00201 ~ X71364	X00201 ~ X71349	÷16+ *1,2
Output Relay	Y00201 ~ Y71364	Y00201 ~ Y71349	÷16+ *1
Internal Relay	I0001 ~ I32768	I0001 ~ I32753	÷16+
Joint Relay	E0001 ~ E4096	E0001 ~ E4081	÷16+
Special Relay	M0001 ~ M9984	M0001 ~ M9969	÷16+
Link Relay	L00001 ~ L72048	L00001 ~ L72033	÷16+
Timer (contact)	T0001 ~ T2047	---	*2
Counter (contact)	C0001 ~ C2047	---	*2
Timer (current value)	---	TP0001 ~ TP2047	L/H
Timer (setup value)	---	TS0001 ~ TS2047	*2
Counter (current value)	---	CP0001 ~ CP2047	
Counter (setup value)	---	CS0001 ~ CS2047	*2
Data Register	---	D0001 ~ D2047	Bit 5
File Register	---	B0001 ~ B2047	Bit 5
Joint Register	---	R0001 ~ R2047	Bit 5
Special Register	---	Z001 ~ Z1024	Bit 5
Link Register	---	W00001 ~ W11024	Bit 5 *3

(Continued on next page)

*1 The value of the terminal number (bit), 01~49, of the last two digits for the Input Relay and Output Relay can only be a multiple of 16 +1.

E.g. For X00201

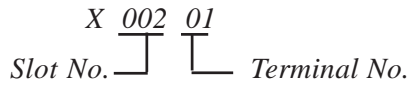

*2 Cannot perform data write.

*3 A total of up to 4,096 link registers can be used.



- Write the CPU Number (1~4) in front of the device name.

E.g. For Internal Relay I0001, CPU #3:

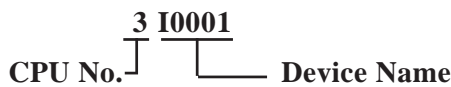

The range of device that can be used will vary depending on the type of PLC. For detailed information refer to the Yokogawa's Sequence CPU manual.

- When setting tags up in GP-PRO/PBIII for Windows, the PLC Station number can be specified during address Input. If a station number is not designated, it automatically uses the previously entered station number. (The initial default value is 1.)

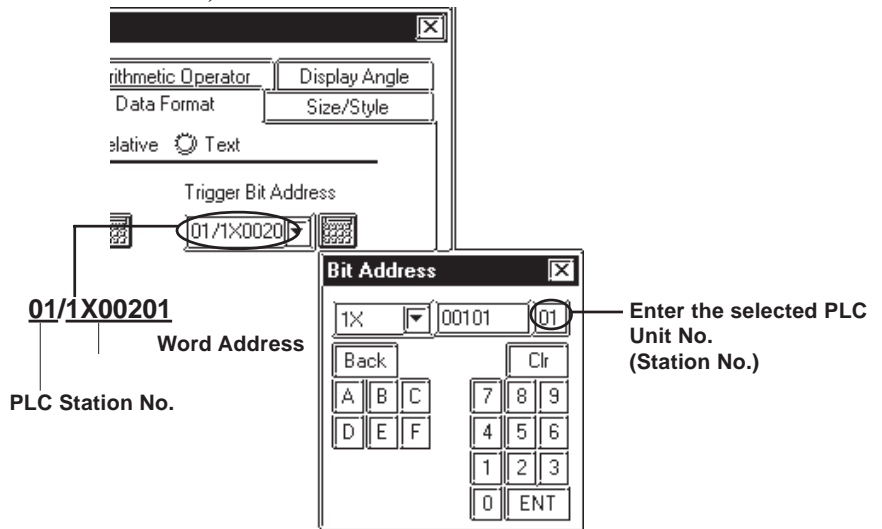

When converting addresses of Joint Relays used in GP-*10/ GP-*30/ GP-*50 Series unit project screens, all addresses will be converted to CPU No. 1 addresses. After all screens are converted, be sure to check all Joint Relay CPU numbers.

5.5.4 Environment Setup

The following lists Digital's recommended PLC and GP communication settings.

■ FACTORY ACE Series

GP Setup		Link I/F Setup	
Baud Rate	19200 bps	Baud Rate	19200 bps
Data Length	8 bits	Data Bit	8 bits
Stop Bit	1 bit	Stop Bit	1 bit
Parity Bit	None	Parity Bit	None
Data Flow Control	ER Control	---	
Communication Format	4-wire type	---	
---		Check Sum	No
---		Specify End Character	Yes
---		Protect Function	No
---		Data Format Setup Switch	8 OFF
Unit No.	1	Station Number	1
Unit. No. (n:m Comm)	Match so all GP, PC Link Unit station no.s are the same.	Station No. (n:m Comm)	Setup so all PA Equip., PC Link Unit no.'s are different.