

# Device/PLC Connection Manuals

---



## About the Device/PLC Connection Manuals



Prior to reading these manuals and setting up your device, be sure to read the "Important: Prior to reading the Device/PLC Connection manual" information. Also, be sure to download the "Preface for Trademark Rights, List of Units Supported, How to Read Manuals and Documentation Conventions" PDF file. Furthermore, be sure to keep all manual-related data in a safe, easy-to-find location.

## 13.4 Yaskawa Electric Inverters

### 13.4.1 System Structure

This section explains the system structure for the connection between an inverter made by Yaskawa Electric and the GP/GLC/LT.

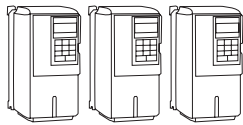
#### ■ Varispeed G7/F7 Series

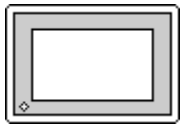

Inverter <sup>*1</sup>	Link I/F	Cable Diagram	GP/GLC/LT
			
CIMR-G7A□□□□ CIMR-F7A□□□□	Communication connector on inverter	RS-422 (1:1 connection, 4-wire type) <Cable Diagram 1> RS-422 (1:n connection, 4-wire type) <Cable Diagram 2> RS-422 (1:1 connection, 2-wire type) <Cable Diagram 3> RS-422 (1:n connection, 2-wire type) <Cable Diagram 4>	GP Series <sup>*2</sup> GLC Series <sup>*3</sup> LT Type C

\*1 The • in the inverter model differs depending upon the maximum applicable motor capacity.

\*2 This inverter cannot be used with the GP70 series except for the GP377 series.

\*3 This inverter cannot be used with the GLC100 series.

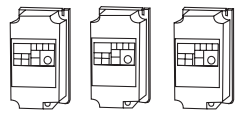
#### ■ Vs mini V7/J7 Series

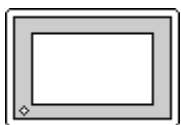
Inverter <sup>*1</sup>	Link I/F	Cable Diagram	GP/GLC/LT
			
CIMR-V7□A□□□□	Communication connector on inverter	RS-422 (1:1 connection, 4-wire type) <Cable Diagram 1> RS-422 (1:n connection, 4-wire type) <Cable Diagram 2>	GP Series <sup>*2</sup> GLC Series <sup>*3</sup> LT Type C
CIMR-J7□A□□□□	RS-422/RS-485 I/F card (S1-485/J7)	RS-422 (1:1 connection, 2-wire type) <Cable Diagram 3> RS-422 (1:n connection, 2-wire type) <Cable Diagram 4>	

\*1 The • in the inverter model differs depending upon the maximum applicable motor capacity.

\*2 This inverter cannot be used with the GP70 series except for the GP377 series.

\*3 This inverter cannot be used with the GLC100 series.

■ Connection Structure

◆ 1 : 1 connection

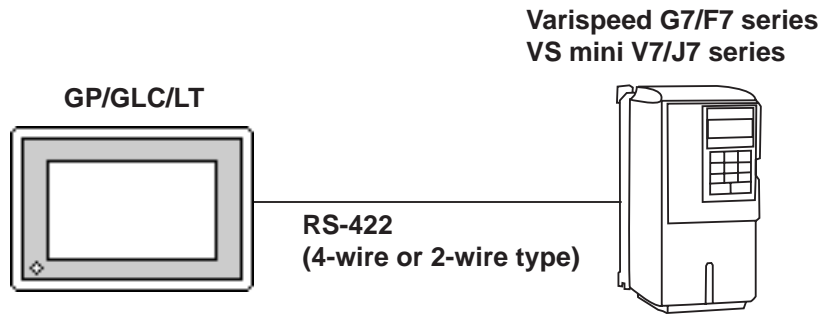

◆ 1 : n connection

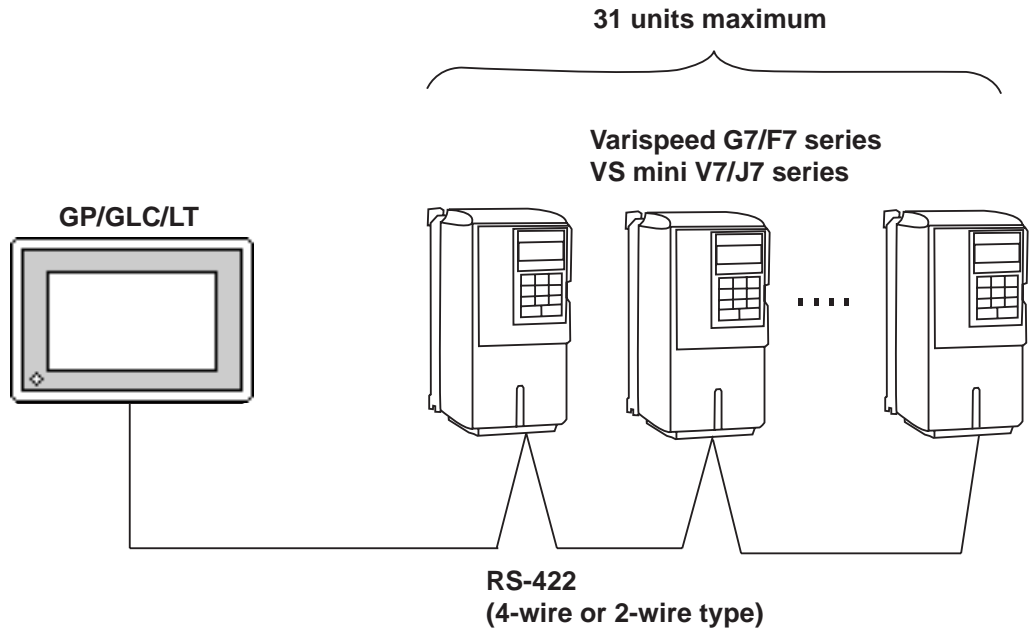

**13.4.2 Cable Diagrams**



- **Separate the communication wiring from the main circuit wiring and other power line.**
- **Ground the FG according to your country's applicable standards.**
- **When the RS-422 port is used, limit the cable length to 500 meters.**
- **To connect the shielded cable to the FG, use the ground terminal on the inverter rather than that on the GP.**

**Cable Diagram 1 (1:1 RS-422, 4-wire type)**

<When using Digital's RS-422 connector terminal adapter GP070-CN10-0>

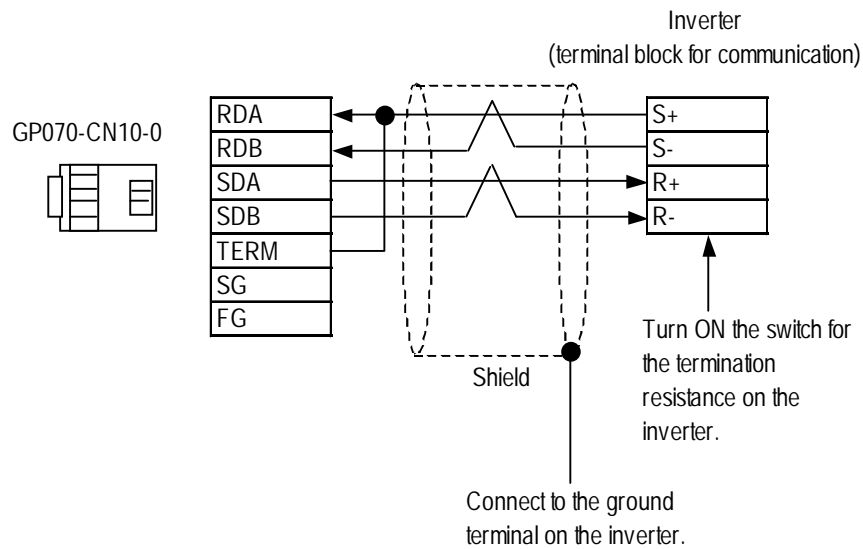

<When making your own connection>

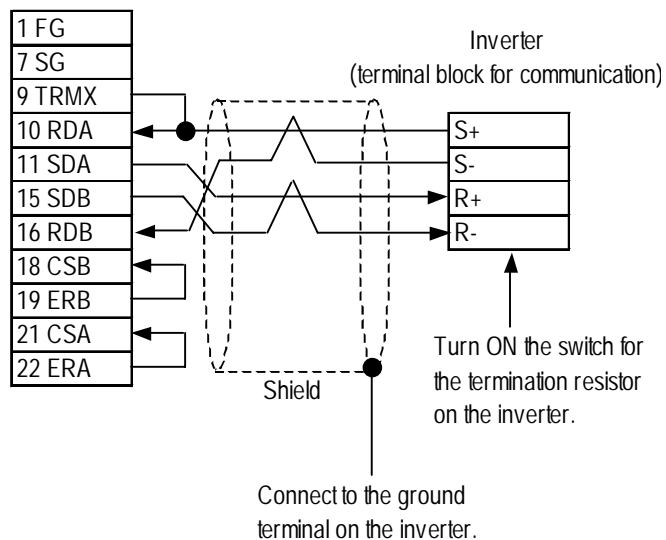

**Cable Diagram 2 (1:n RS-422, 4-wire type)**

<When using Digital's RS-422 connector terminal adapter GP070-CN10-0>

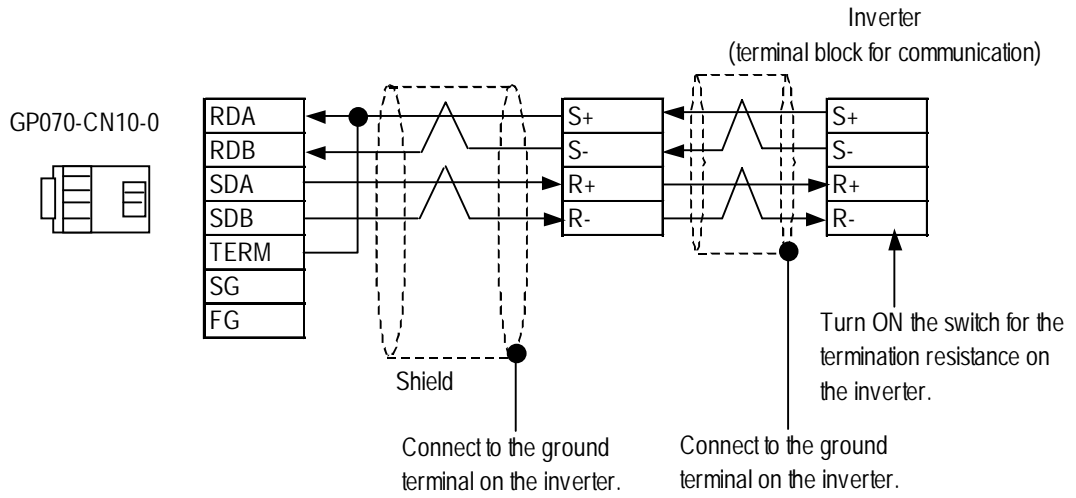

<When making your own connection>

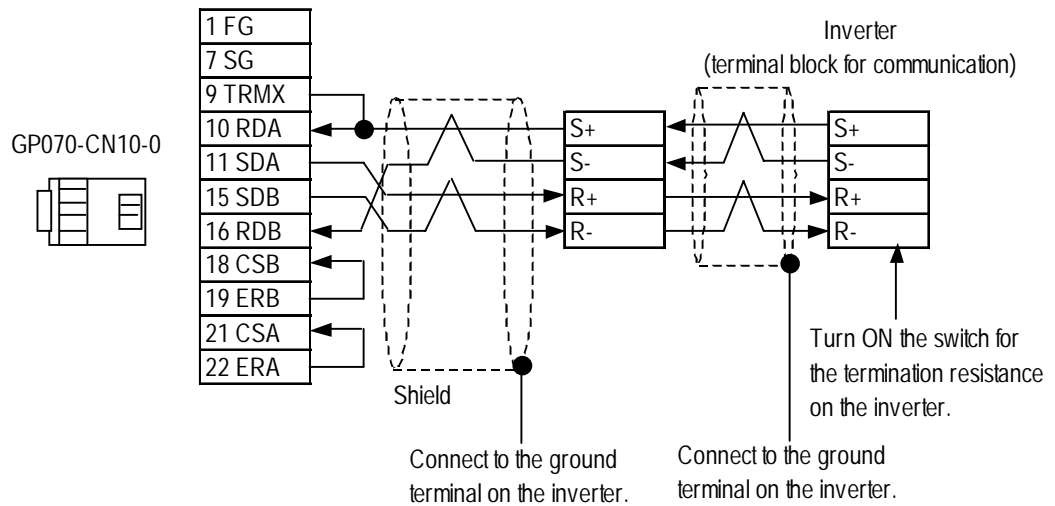

**Cable Diagram 3** (1:1 RS-422, 2-wire type)

<When using Digital's RS-422 connector terminal adapter GP070-CN10-0>

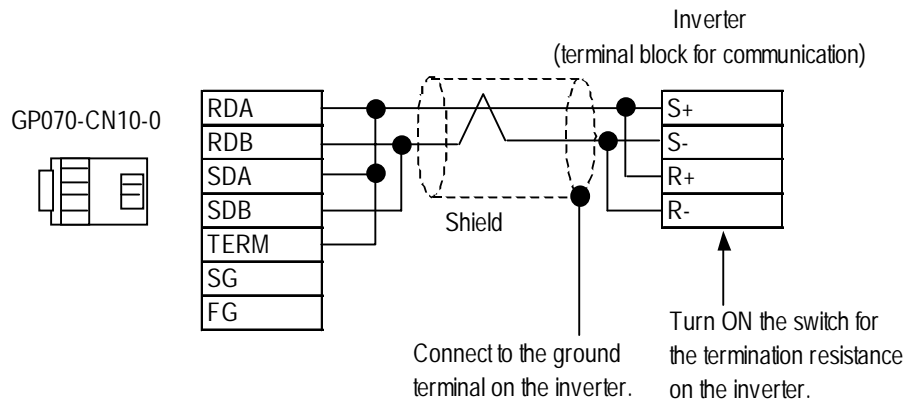

<When making your own connection>

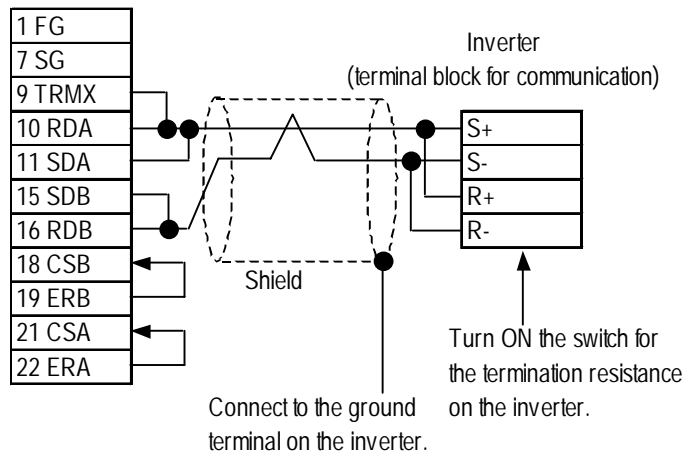

**Cable Diagram 4 (1:n RS-422, 2-wire type)**

<When using Digital's RS-422 connector terminal adapter GP070-CN10-0>

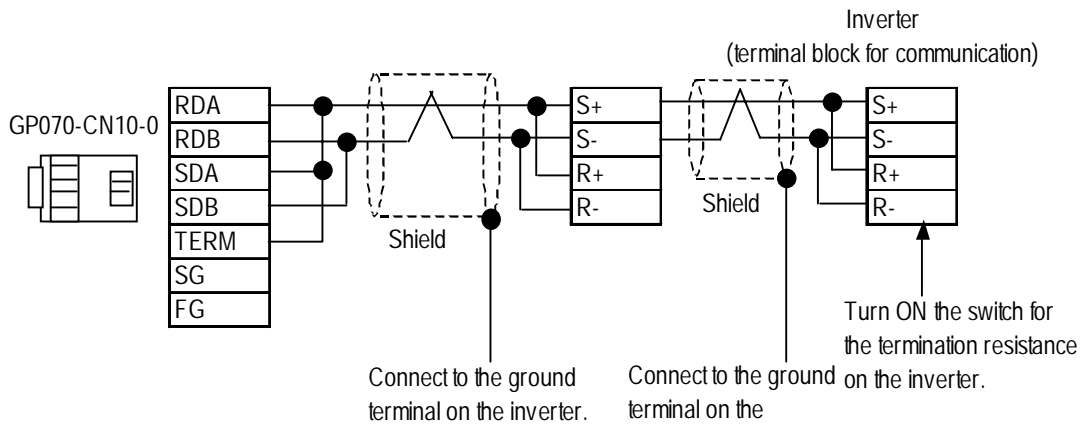

<When making your own connection>

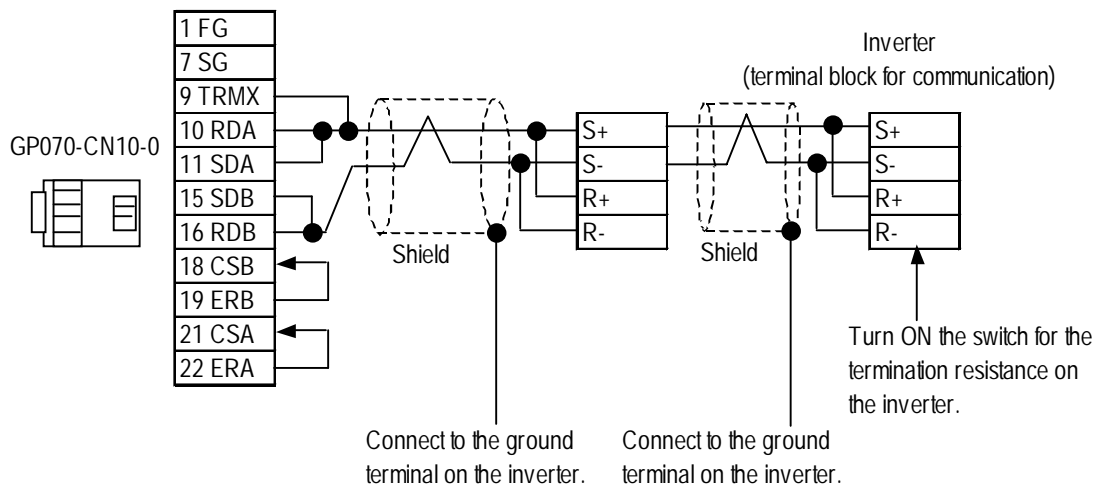

**13.4.3 Supported Devices**

**Varispeed G7/F7 Series vs. mini V7/J7 Series**

   Setup System Area here.

Device	Bit Addresses	Word Addresses	Remarks
Bit Register	BR00000 ~ BR03FFF	_____	*1*2*3*4 L/H
	BR04000 ~ BR07FFF	_____	
	BR08000 ~ BR0BFFF	_____	
Register	_____	0000 ~ 03FF	*1*2 <span style="border: 1px solid black; padding: 2px;">Bit F</span>
	_____	0400 ~ 07FF	
	_____	0800 ~ 0BFF	

\*1 The available register numbers and the availability of read/write are different depending upon the inverter models. For further information, refer to the instruction manual for each inverter model.

\*2 Specify the MEMOBUS register number indicated in the instruction manual for your inverter. As an example, the correspondence of the constant numbers and names of the inverter to register numbers is shown below. For further information, refer to the instruction manual for each inverter model.

Ex) Inverter Constant Numbers, Names and Register Numbers

Constant No.	Name	Description	Setting Range	Default Value	Change during Operation	Control Mode			MEMOBUS Register
						V/f without PG	V/f with PG	Vector without PG	
A1-02	Selection of Control Mode	Select an inverter control mode. 0: V/f control without PG 1: V/f control with PG 2: Vector control without PG The control mode is not initialized by selecting INITIALIZE.	0 ~ 2	0	x	0	0	0	102H
b1-01	Selection of frequency command	Select a frequency command input method. 0: Digital operator 1: Control circuit terminal (analog input) 2: MEMOBUS communication 3: Optional card 4: Pulse column input	0 ~ 4	1	x	0	0	0	180H

Register No.



**Settings on GP-PRO/PBIII for Windows**

<Bit register>

01/BR 0001 F

- Bit address (use 0 to F)
- Device address (MEMOBUS register number of inverter)
- Device name
- Station address of inverter

Enter the station address of the inverter to be specified.

<Register>

01/0001

- Device address (MEMOBUS register number of inverter)
- Station address of inverter

Enter the station address of the inverter to be specified.

\*3 When data is written, the values other than those for the specified bits of the selected register are retained. (Immediately before data is written, the data on the selected register is temporarily read out, and then written with only the specified bits rewritten.)

\*4 To write bits to a write-only register, use the register device instead. Trying to write data to a write-only register will result in a host communication error (02:02:##) (## stands for the station address at which the error has occurred). Refer to "15.4.5 Error Codes."



- **The system data area (20 words) of the GP/GLC/LT cannot be allocated to the data area available on the inverter. Even if the system data area is set using the GP-PRO/PBIII or the offline GP/GLC/LT, this allocation cannot be made. To use the read-in area, specify the first address of the system area.**

### 13.4.4 Environment Setup

#### ■ Varispeed G7/F7 Series

GP/GLC/LT Settings		Inverter Settings	
Baud Rate	9600bps	Port Transmission Rate	9600bps
Data Length	8bit	Data Length	8 bits (fixed)
Stop Bit	2bit	Stop Bit	1 bit (fixed)
Parity Bit	Even	Parity Bit <sup>*1</sup>	Even Parity
Control Method	ER Control	RTS Control	Provided
Communication Format	2-wire/4-wire type	_____	_____
Station No. (DEC)	1	Station Address (HEX)	1 ~ 1F
_____		Selection of Frequency Command <sup>*2</sup>	MEMOBUS Communication
		Selection of Operation Command <sup>*3</sup>	MEMOBUS Communication

*\*1 The default value is Parity Invalid.*

*\*2 Make this selection when issuing the frequency command from the GP/GLC/LT.*

*\*3 Make this selection when issuing the operation command from the GP/GLC/LT.*

#### ■ VS mini V7/J7 Series

GP/GLC/LT Settings		Inverter Settings	
Baud Rate	9600bps	Port Transmission Rate	9600bps
Data Length	8bit	Data Length	8 bits (fixed)
Stop Bit	2bit	Stop Bit	1 bit (fixed)
Parity Bit	Even	Parity Bit	Even Parity
Control Method	ER Control	RTS Control	Provided
Communication Format	2-wire/4-wire type	_____	_____
Station No. (DEC)	1	Station Address (DEC)	1 ~ 31
_____		Selection of Frequency Command <sup>*1</sup>	MEMOBUS Communication
		Selection of Operation Command <sup>*2</sup>	MEMOBUS Communication

*\*1 Make this selection when issuing the frequency command from the GP/GLC/LT.*

*\*2 Make this selection when issuing the operation command from the GP/GLC/LT.*

**13.4.5 Error Codes**

<Inverter Error Codes>

An error code specific to the inverter is displayed in the lower left corner of the GP screen such as "Host communication error (02:\*\*:##)." \*\* stands for the error code specific to the PLC. ## stands for the station address of the inverter where the error has occurred.

**■ Error Codes**

Error Code	Error Name	Description
01	Function code error	A function code that is not available on the inverter was used.
02	Wrong register number	The register you tried to access is not used. A register that is not used was specified at the start address for continuous read-out.
03	Wrong number of registers	The number of read-out data is not within a range between 1 and 16. When data was written, the number of data in the message is not the number of registers multiplied by 2.
21	Setting error	When any control data or constant was written, it was outside the allowable setting range.
22	Write mode error	When the inverter is protected from write (e.g., during its operation), you tried to write data. Data was written to a read-only register.
23	Write during UV operation	Data was written when the main circuit was at low voltage (UV).
24	Write during processing of constants	You tried to write data when the inverter was processing constants.