

Device/PLC Connection Manuals



About the Device/PLC Connection Manuals

Prior to reading these manuals and setting up your device, be sure to read the "Important: Prior to reading the Device/PLC Connection manual" information. Also, be sure to download the "Preface for Trademark Rights, List of Units Supported, How to Read Manuals and Documentation Conventions" PDF file. Furthermore, be sure to keep all manual-related data in a safe, easy-to-find location.



Ubon Corporation PLC

1 System Structure

The following describes the system structure for connecting the GP to Ubon Corporation PLCs.

Reference *The Cable Diagrams mentioned in the following tables are listed in the section titled "2.2.2 Cable Diagrams".*

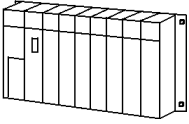
■ UPZ Series (using Link I/F)

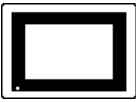
CPU	Link I/F	Connection Diagram	Target Machine
			
UPZ3-16ND1-16TD1 UPZ3-T UPZ2-M	CPU unit Link I/F ^{*1}	RS-232C <Connection Diagram 1>	GP/GLC Series
			ST 401
		RS-422 <Connection Diagram 2>	GP/GLC Series
			ST 400

* 1 Connect to the CPU Module's general purpose communication port.

2 Cable Diagrams

The cable diagrams illustrated below and the cable diagrams recommended by Hitachi Ltd. may differ; however, using these cables for your PLC operations will not cause any problems.



Ground your PLC's FG terminal according to your country's applicable standard. For details, refer to the corresponding PLC manual.



- **Connect the FG line of the Shield cable to either the GP or PLC, depending on your environment. When using a connector hood and grounding the FG line, be sure to use an electrical conductor. The following connection diagrams show examples for connecting a shielded cable to the PLC.**

- **When using an RS-232C cable, the cable length must be less than 15m.**
- **If a communications cable is used, it must be connected to the SG (signal ground).**
- **When using an RS-232C cable, the cable length must be less than 600m.**

Cable Diagram 1 (RS-232C)

◆ With a GP/GLC Series unit

- When making your own cable

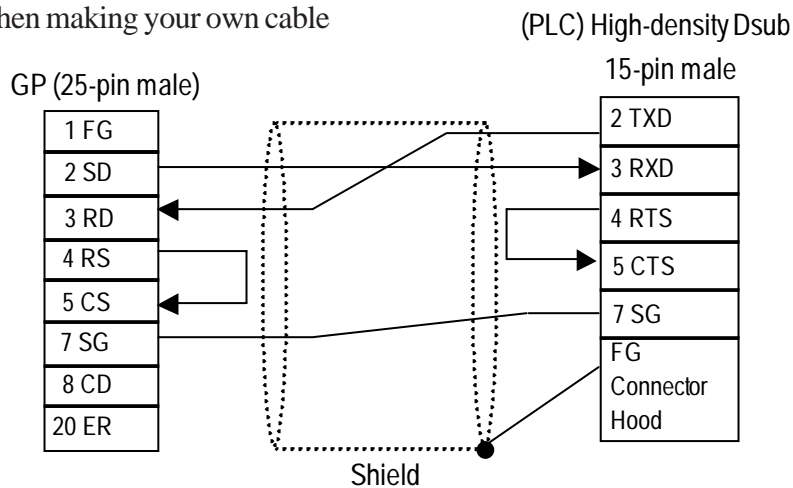

◆ With an ST401 unit

- When making your own cable

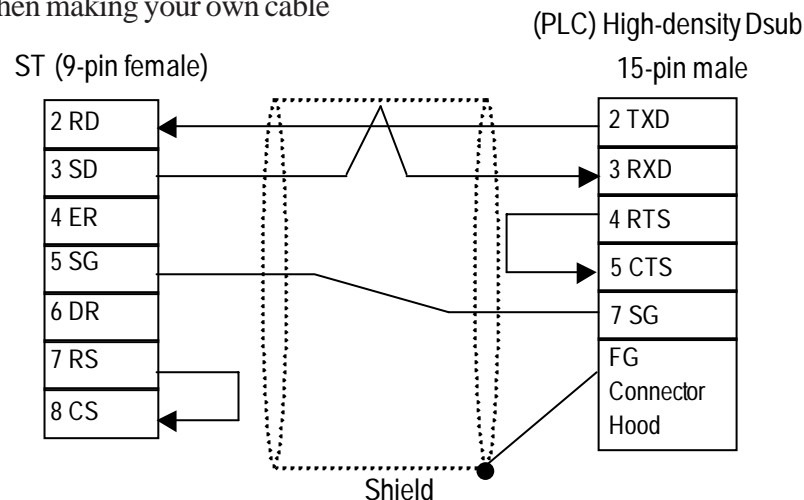

Cable Diagram 2 (RS-422)

◆ With a GP/GLC Series unit

- When using Digital's RS-422 connector terminal adapter GP070-CN10-0

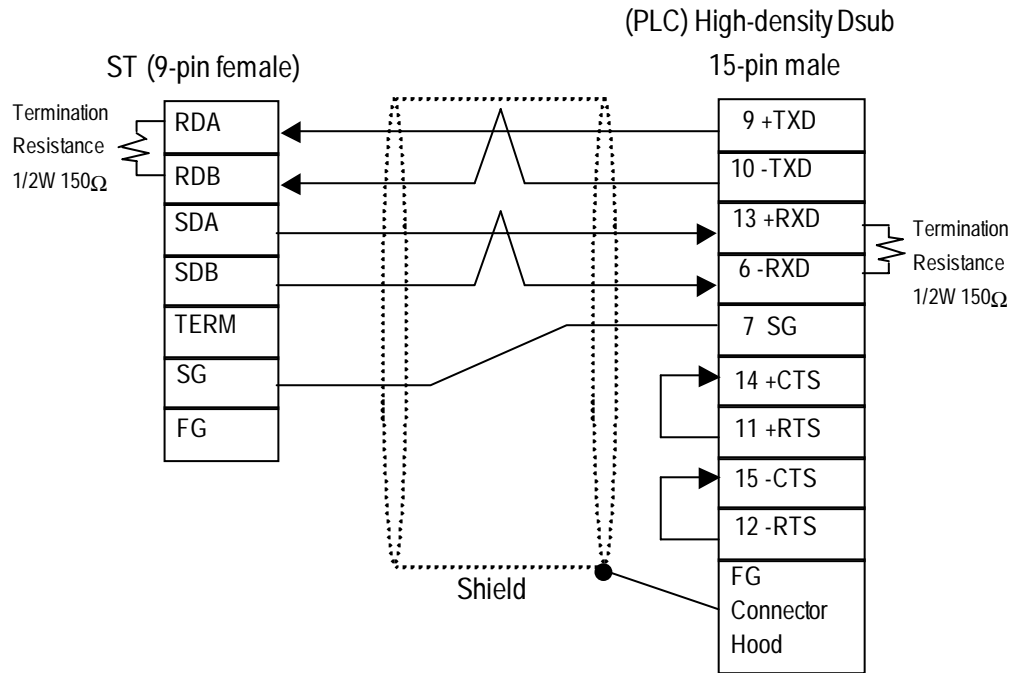

- When making your own cable

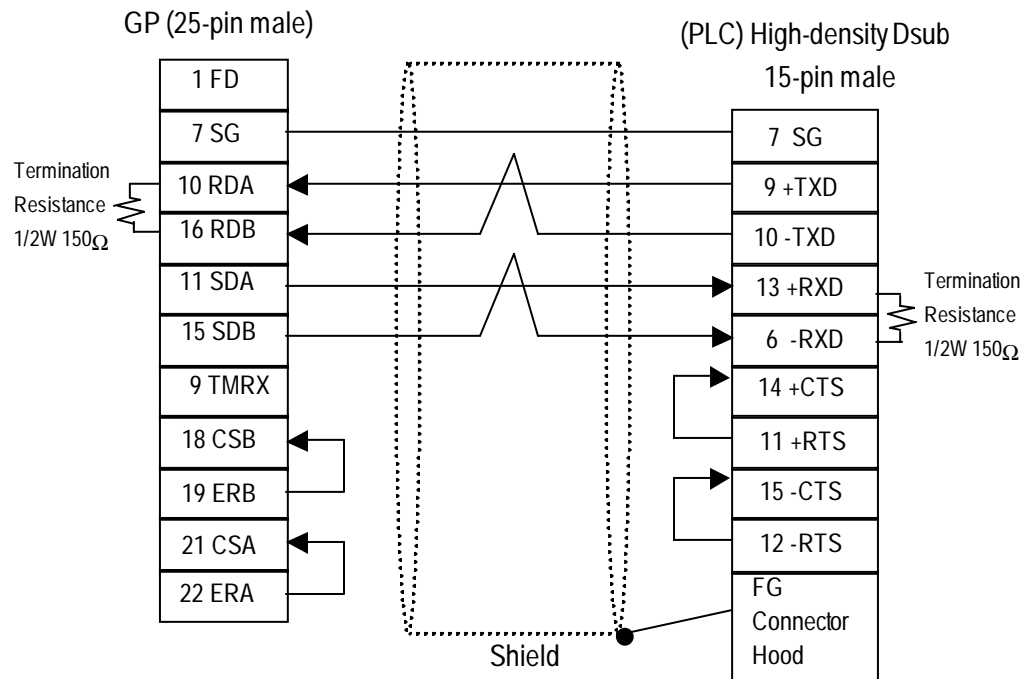

◆ **With an ST401 unit**

- When making your own cable

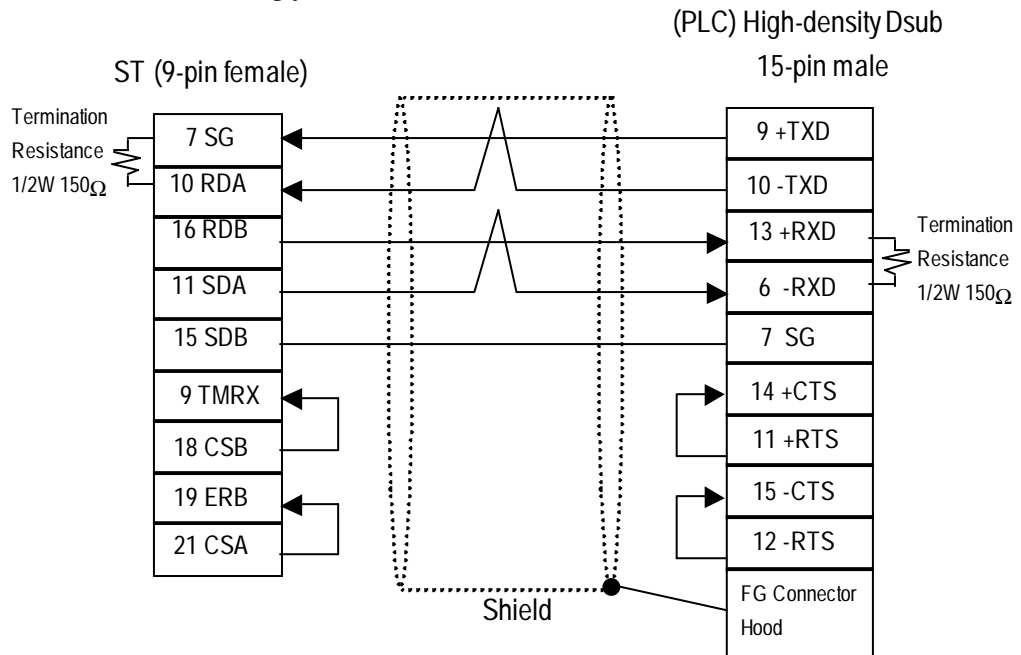

















3 Supported Devices

The following describes the range of devices supported by the GP.

■ UPZ Series

 Setup System Area here.

Device	Bit Address	Word Address	Remarks
Input Relay	I000 to I777	R40400 to R40437	 *1
Output Relay	Q000 to Q777	R40500 to R40537	
Internal Relay	M0000 to M1777	R40600 to R40677	
Stage	S0000 to S1777	R41000 to R41037	
Special Relay	SP000 to SP777	R41200 to R41237	 *2
Timer	T000 to T377	R41100 to R41117	
Counter	C000 to C177	R41140 to R41147	
Timer (Elapsed Time)	————	R000 to R377	
Counter (Elapsed Time)	————	R1000 to R1177	
Data Register	————	R1400 to R7377	 
	————	R10000 to R17777	 
Special Register	————	R7400 to R7777	  *2
	————	R37000 to R37777	  *2

L/H

*1 Addresses allocated to the PLC or the I/O units can not be written to.

*2 Certain addresses may not be able to be written to. (No write error will occur, however the data written will not be reflected in the address.)

4 Environment Setup

The following table lists Digital's recommended PLC and GP communication settings.

■ UPZ Series

GP Setup		PLC Settings	
Baud Rate	9600 bps	Baud Rate	9600 bps
Data Length	8 bit (fixed)	_____	
Stop Bit	1 bit (fixed)	Stop Bit	1 ^{*1}
Parity Bit	Odd	Parity Bit	Odd
Data Flow Control	ER Control	_____	
Communication Format (RS-232C)	RS-232C	_____	
Communication Format (RS-422)	4-wire type	_____	
Unit No.	0	Station Number	0
_____		Protocol	CCM Net (DirectNET)
_____		Data Type	Hex

**1 Even though this setting can be changed, it should always be left at "1".*