

Device/PLC Connection Manuals



About the Device/PLC Connection Manuals

Prior to reading these manuals and setting up your device, be sure to read the "Important: Prior to reading the Device/PLC Connection manual" information. Also, be sure to download the "Preface for Trademark Rights, List of Units Supported, How to Read Manuals and Documentation Conventions" PDF file. Furthermore, be sure to keep all manual-related data in a safe, easy-to-find location.

12.8 Toho Electronics Inc. Controllers



12.8.1 System Structure

The following describes the system configuration used when connecting the GP/GLC/LT to this Controller.





- **After the Controller's power is turned ON, no communication is performed for about four seconds. As a result, note that it may take several seconds to start communication when the GP/GLC/LT and the Controller are turned ON at the same time.**
- **When a save request command is sent to the Controller (STR write command), it can take up to six seconds for the controller to respond. At this time, note that the communication speed may slow significantly, which is indicated by the slowing of the update frequency of the GP/GLC/LT display, as the GP/GLC/LT enters the standby state.**

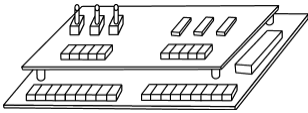

■ TTM-004/X04

Temperature Controller	Cable Diagram	GP/GLC/LT
		
TTM-004-□-A□□□ TTM-X04-□-□□□□	RS-422 (2-wire type) <Cable diagram 1>	GP or GLC series LT Type C
	RS-422 (2-wire type, 1:n) <Cable diagram 3>	

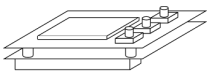

■ TTM-00B

Temperature Controller	Cable Diagram	GP/GLC/LT
		
TTM-00B-□-□□□□	RS-422 (2-wire type) <Cable diagram 1>	GP or GLC series LT Type C
	RS-422 (2-wire type, 1:n) <Cable diagram 3>	

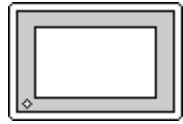

■ TTM-10L

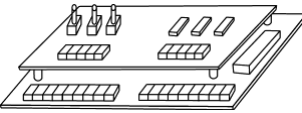
Temperature Controller	Cable Diagram	GP/GLC/LT
		
TTM-10L-□-□-□	RS-422 (2-wire type) <Cable diagram 1>	GP or GLC Series LT Type C
	RS-232C <Cable diagram 2>	
	RS-422 (2-wire type, 1:n) <Cable diagram 3>	



■ TTM-100B

Temperature Controller	Cable Diagram	GP/GLC/LT
		
TTM-100B4-□ □-□ □ □ □-□ □ □ TTM-100B8-□ □-□ □ □ □ □ □-□ □ □	RS-422 (2-wire type) <Cable diagram 1>	GP or GLC Series LT Type C
	RS-422 (2-wire type, 1:n) <Cable diagram 3>	

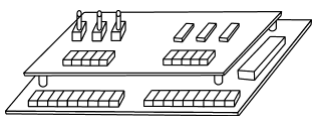

■ TTM-110 Series

Temperature Controller	Cable Diagram	GP/GLC/LT
		
TTM-114-□-□ □-□ □ □ □ □ □ □-□ TTM-115-□-□ □-□ □ □ □ □ □ □ □-□ TTM-117-□-□ □-□ □ □ □ □ □ □ □-□ TTM-119-□-□ □-□ □ □ □ □ □ □ □-□	RS-422 (2-wire type) <Cable diagram 1>	GP or GLC Series LT Type C
	RS-422 (2-wire type, 1:n) <Cable diagram 3>	



■ TTM-110B Series

Temperature Controller	Cable Diagram	GP/GLC/LT
		
TTM-110B-□-□ □-□□□□□□-□	RS-422 (2-wire type) <Cable diagram 1>	GP or GLC series LT Type C
	RS-422 (2-wire type, 1:n) <Cable diagram 3>	

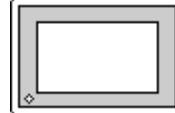

■ TTM-120 Series

Temperature Controller	Cable Diagram	GP/GLC/LT
		
TTM-124-□-□ □-□□□□□□-□ TTM-125-□-□ □-□□□□□□-□ TTM-127-□-□ □-□□□□□□-□ TTM-129-□-□ □-□□□□□□-□	RS-422 (2-wire type) <Cable diagram 1>	GP or GLC series LT Type C
	RS-422 (2-wire type, 1:n) <Cable diagram 3>	

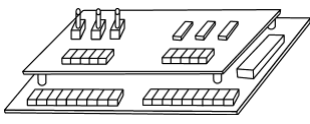

■ TTM-300 Series

Temperature Controller	Cable Diagram	GP/GLC/LT
		
TTM-304-□-□N-□□□□-□ TTM-305-□-□N-□□□□-□ TTM-309-□-□N-□□□□-□	RS-422 (2-wire type) <Cable diagram 1>	GP or GLC series LT Type C
	RS-422 (2-wire type, 1:n) <Cable diagram 3>	

■ TTM-300B

Temperature Controller	Cable Diagram	GP/GLC/LT
		
TTM-300B-□-□N-□□□□-□	RS-422 (2-wire type) <Cable diagram 1>	GP or GLC Series LT Type C
	RS-422 (2-wire type, 1:n) <Cable diagram 3>	

■ TTM-1020 Series

Temperature Controller	Cable Diagram	GP/GLC/LT
		
TTM-1520-□ □-□ □-□□□-□ TTM-1521-□ □-□ □-□□□-□ TTM-1522-□ □-□ □-□□□-□ TTM-1523-□ □-□ □-□□□-□ TTM-1524-□ □-□ □-□□□-□ TTM-1525-□ □-□ □-□□□-□ TTM-1920-□ □-□ □-□□□-□ TTM-1921-□ □-□ □-□□□-□ TTM-1922-□ □-□ □-□□□-□ TTM-1923-□ □-□ □-□□□-□ TTM-1924-□ □-□ □-□□□-□ TTM-1925-□ □-□ □-□□□-□	RS-422 (2-wire type) <Cable diagram 1>	GP or GLC Series LT Type C
	RS-422 (2-wire type, 1:n) <Cable diagram 3>	

12.8.2 Cable Diagrams

The cable diagrams shown below and the cable diagrams recommended by Toho Electronics Inc. may differ, however, using these cables for your Controller's operations will not cause any problems.



- **RS-422 connector terminal numbers will differ depending on the controller model. Prior to performing wiring, refer to your controller's User Manual.**
- **When using RS-232C format, all cables should be no more than 15 meters long and also using RS-422 format, all cables should be no more than 50 meters long.**

■ Cable Diagram 1 (1:1) RS-422 (2-wire type)

- Using Digital's RS-422 connector terminal adapter GP070-CN10-0

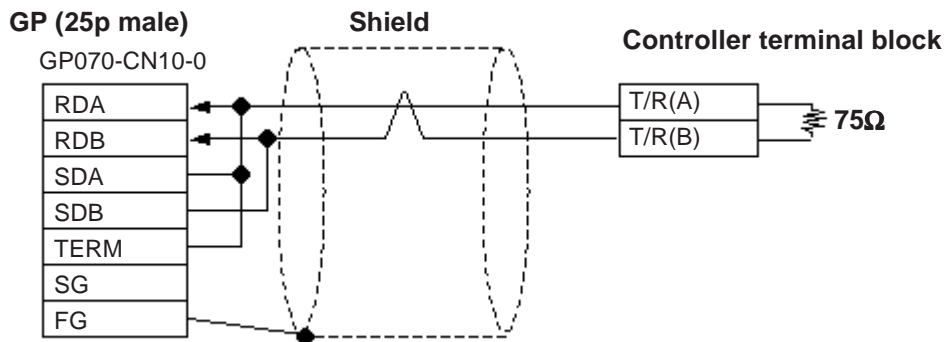

- Using Digital's RS-422 Cable GP230-IS11-0

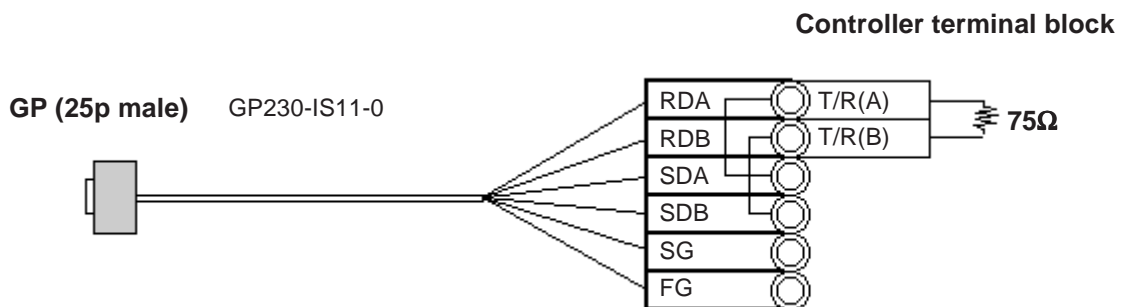

Note: Be sure that RDA - SDA and RDB - SDB are both connected to the Controller terminal block.



Since the SG and FG lines cannot be connected to the controller terminal block, be sure to cover them with insulating tape.

- When making your own cables

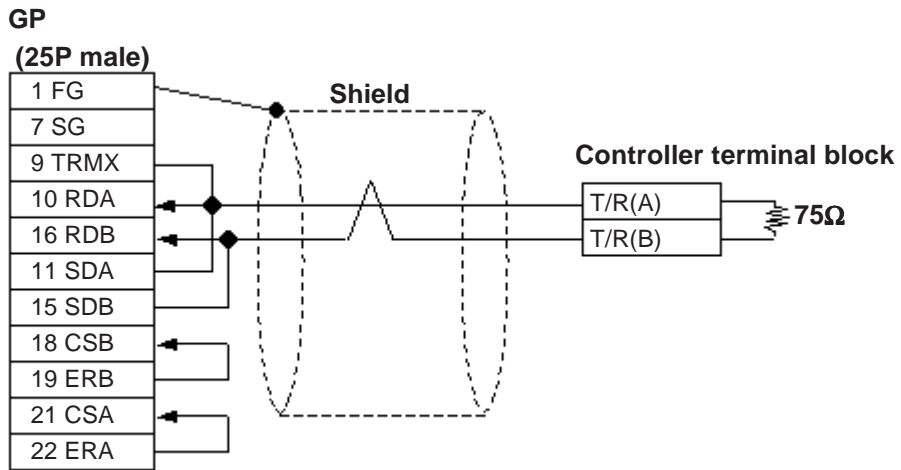

When connecting the No.9 pin and No.10 pin in the GP Serial I/F, a termination resistance of 100Ω is added between RDA and RDB.

■ Cable Diagram 2 RS-232C

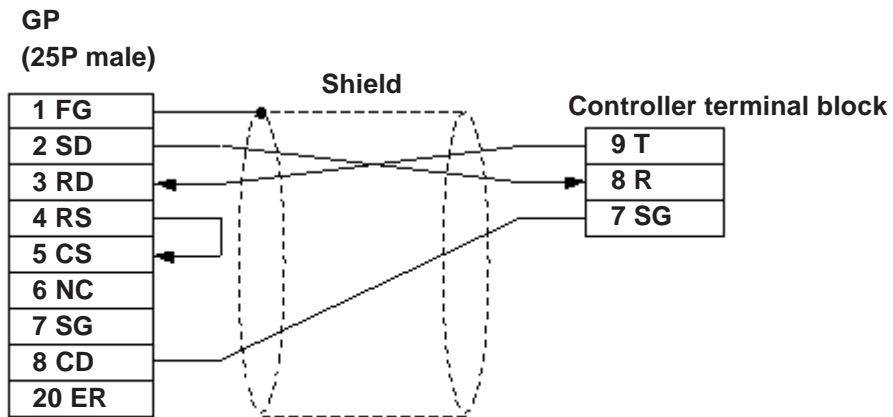

■ Cable Diagram 3 (1:n) RS-422



Ground a shielded cable in accordance with the electrical requirements of your system, using one of the following three methods.

- (1) Distributed grounding (as shown below)
- (2) Parallel grounding, or
- (3) Serial grounding.

• Using Digital's RS-422 connector terminal adapter GP070-CN10-0

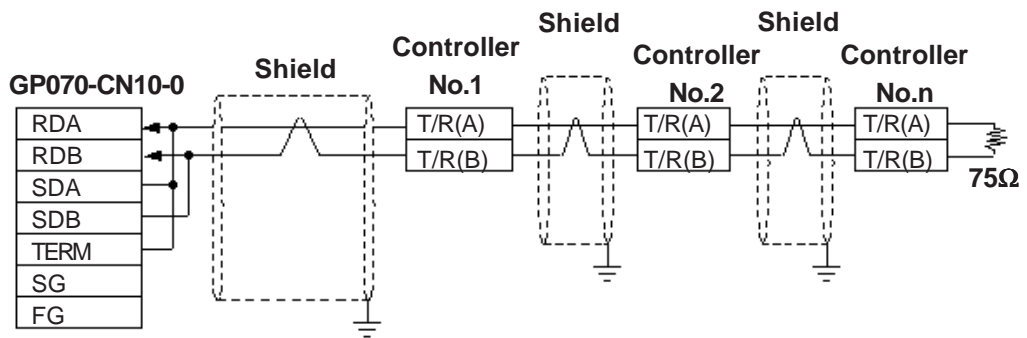

• Using Digital's RS-422 cable, GP230-IS11-0

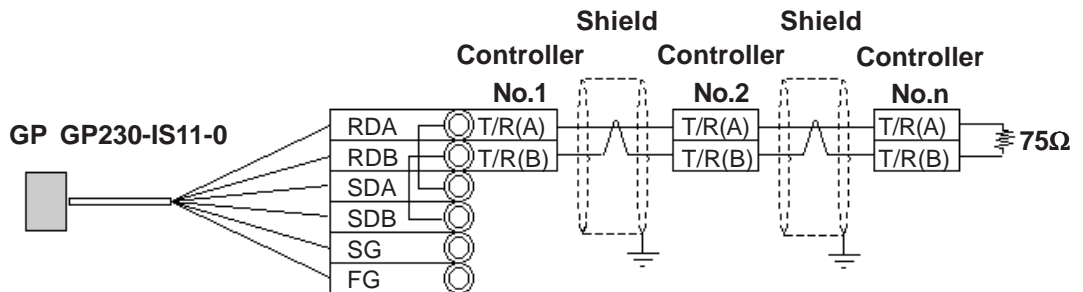

- Be sure that RDA - SDA and RDB - SDB are both connected to the Controller terminal block.



Since the SG and FG lines cannot be connected to the controller terminal block, be sure to cover them with insulating tape.

- When making your own cable connections

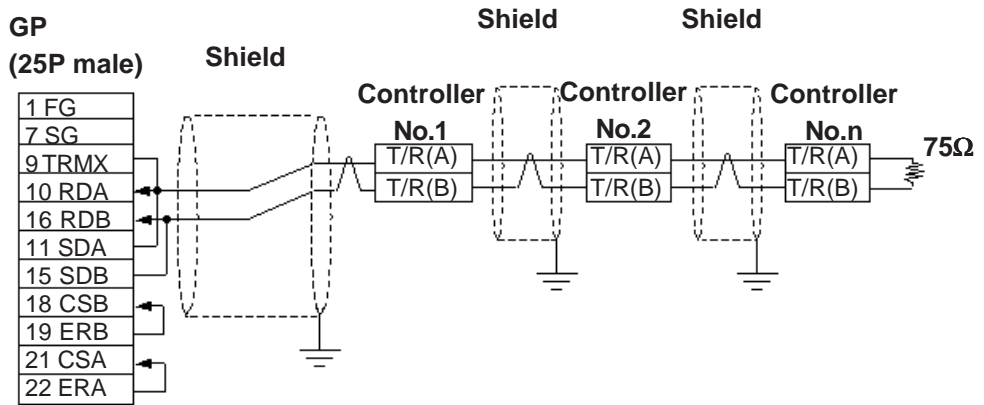

- When connecting the No.9 pin and No.10 pin in the GP Serial I/F, a termination resistance of 100Ω is added between RDA and RDB.

12.8.3 Supported Devices

The following list shows the range of devices supported by the GP/GLC.



Important

- **The Controller identifiers "1" and "2" (refer to your Controller's User Manual) are assigned to predefined addresses and devices. As a result, when you enter devices on the GP screen editor software, do so as shown below.**

Device Selection

(Select from 00_, 10_, 100_,
110_, 120_, 300_ or 1020_)

Address Selection

(Refer to Supported
Devices List on
following pages.)

Enter the Controller's
Communication Unit No.
(Station No.)

- **Each identifier has read and write limitations detailed information, refer to your Controller's Instruction Manual. For details about precautions when using identifier "2" with GP-PRO/PBIII, refer to TTM-300 Series Supported Device's *1 or *2.**
- **GP/GLC/LT's System Area (LS0 to LS19) Settings**
The GP/GLC/LT's system area (20 words) cannot be allocated to the Controller's own data area. Even though you can enter the system area settings via the GP's screen editor software or via the GP/GLC/LT's OFFLINE screen, it is impossible to actually allocate the system area to the Controller's data area.
- **When you save data to your Controller's EEPROM (send a Save request), write it in the device address corresponding to symbol STR or identifier STR. For the TTM-300 series, this procedure is not needed since it saves data directly to the EEPROM.**
- **When saving data to the EEPROM, write the data to the device address that corresponds to your Controller's STR identifier.**



- **In the Read Area, only the devices "00_ ", "10_ ", "100_ ", "110_ ", "120_ ", "300_ " and "1020_ " can be set. All other devices, "SSV", "END", "STI", "SOK", "SWZ", "SWT", "SON", "SOF", "SRN" and "SEO" cannot be used.**
- **Depending on the Controller's setting conditions, the GP/GLC/LT's pre-set setting values may be used. Refer to the table as shown below.**

Model	Address	Identifier	Controller Condition	Decimal marked values using on GP/GLC/LT (Hex)
TTM-004/X04/00B (00_)	0	PV1	Over Scale	32767(0x7FFF)
			Under Scale	-32768(0x8000)
	2 - 10	PR1 - PR9	When an arbitrary identifier has been assigned to the priority screen. (When the display of PR1 to PR9 on the temperature controller is not OFF.)	0011 ~ 0077 *1
			In the case where no setting has been assigned to the priority screen. (When the display of PR1 to PR9 on the temperature controller is OFF.)	-32768(0x8000)
			In the case where the identifier COM has been assigned to the priority screen.	32767(0x7FFF) *2
			In the case where the identifier BPS has been assigned to the priority screen.	32766(0x7FFE) *2
			In the case where the identifier ADR has been assigned to the priority screen.	32765(0x7FFD) *2
			In the case where the identifier AWT has been assigned to the priority screen.	32764(0x7FFC) *2
			In the case where the identifier MOD has been assigned to the priority screen.	32763(0x7FFB) *2
	TTM-10L (10_)	0	PV1	Over Scale
Under Scale				-32768(0x8000)
22		□CJ	Over Scale	32767(0x7FFF)
			Under Scale	-32768(0x8000)
23		PV2	Over Scale	32767(0x7FFF)
			Under Scale	-32768(0x8000)
TTM-100B (100_)	0	PV1	Over Scale	32767(0x7FFF)
			Under Scale	-32768(0x8000)
TTM-110/110B (110_)	0	PV1	Over Scale	32767(0x7FFF)
			Under Scale	-32768(0x8000)
TTM-120 (120_)	0	PV1	Over Scale	32767(0x7FFF)
			Under Scale	-32768(0x8000)
TTM-300/300B (300_)	0	PV1	Over Scale	32767(0x7FFF)
			Under Scale	-32768(0x8000)
	4	□TI	When the Operation has finished	-32768(0x8000)

*1 Addresses allocated to each identifier

▼ **Reference** ▲ 12.8.3 Supported Devices ■ TTM-004/X04/00B

*2 This identifier cannot be registered as the priority screen function setting (PR1 to PR9) via a GP/GLC/LT Write command. To register this function, use the front panel of the temperature controller.

- **You cannot use this device as a 32-bit device, since each identifier's addresses are not consecutive.**

■ TTM-004/X04/00B

Device	Bit Address	Word Address	Controller Setting item	Identifiers	Others
00_	000000 ~ 000015	0000	Process value PV	PV1	
	000100 ~ 000115	0001	Setting value SV	SV1	
	000200 ~ 000215	0002	Priority display set 1	PR1	
	000300 ~ 000315	0003	Priority display set 2	PR2	
	000400 ~ 000415	0004	Priority display set 3	PR3	
	000500 ~ 000515	0005	Priority display set 4	PR4	
	000600 ~ 000615	0006	Priority display set 5	PR5	
	000700 ~ 000715	0007	Priority display set 6	PR6	
	000800 ~ 000815	0008	Priority display set 7	PR7	
	000900 ~ 000915	0009	Priority display set 8	PR8	
	001000 ~ 001015	0010	Priority display set 9	PR9	
	001100 ~ 001115	0011	Set/select of input	INP	
	001200 ~ 001215	0012	Gain for PV correction	PVG	
	001300 ~ 001315	0013	Zero point for PV correction	PVS	
	001400 ~ 001415	0014	Filter input	PDF	
	001500 ~ 001515	0015	Decimal position	<input type="checkbox"/> DP	
	001600 ~ 001615	0016	Function by FUNC Key	<input type="checkbox"/> FU	
	001700 ~ 001715	0017	Lock	LOC	
	001800 ~ 001815	0018	SV H limit	SLH	
	001900 ~ 001915	0019	SV L limit	SLL	
	002000 ~ 002015	0020	Control mode	<input type="checkbox"/> MD	
	002100 ~ 002115	0021	Control type	CNT	
	002200 ~ 002215	0022	Set/select of normal or reverse	DIR	
	002300 ~ 002315	0023	Output1, manipulated value	MV1	
	002400 ~ 002415	0024	Tuning type	TUN	
	002500 ~ 002515	0025	AT coefficient	ATG	
	002600 ~ 002615	0026	AT sensitivity	ATC	
	002700 ~ 002715	0027	Output 1, proportional band	<input type="checkbox"/> P1	
	002800 ~ 002815	0028	Integral time	<input type="checkbox"/> I1	
	002900 ~ 002915	0029	Derivative time	<input type="checkbox"/> D1	
	003000 ~ 003015	0030	Output 1, proportional cycle	<input type="checkbox"/> T1	
	003100 ~ 003115	0031	Anti reset wind-up	ARW	
	003200 ~ 003215	0032	Setting of H limit for Output 2 MV limiter	MH1	
	003300 ~ 003315	0033	Setting of L limit for Output 2 MV limiter	ML1	
	003400 ~ 003415	0034	Output 1, control sensitivity	<input type="checkbox"/> C1	
	003500 ~ 003515	0035	Output 1, OFF position	CP1	
	003600 ~ 003615	0036	Output 2, manipulated value	MV2	
	003700 ~ 003715	0037	Output 2, proportional band	<input type="checkbox"/> P2	
	003800 ~ 003815	0038	Output 2, proportional cycle	<input type="checkbox"/> T2	
	003900 ~ 003915	0039	Setting of H limit for Output 2 MV limiter	MH2	
	004000 ~ 004015	0040	Setting of L limit for Output 2 MV limiter	ML2	
	004100 ~ 004115	0041	Manual reset	PBB	
	004200 ~ 004215	0042	Output 2, control sensitivity	<input type="checkbox"/> C2	
	004300 ~ 004315	0043	Output 2, OFF position	CP2	
	004400 ~ 004415	0044	Dead band	<input type="checkbox"/> DB	
	004500 ~ 004515	0045	EV 1, function	E1F	
	004600 ~ 004615	0046	EV 1, H limit	E1H	
	004700 ~ 004715	0047	EV 1, L limit	E1L	
	004800 ~ 004815	0048	EV 1, sensitivity	E1C	
004900 ~ 004915	0049	EV 1, delay timer	E1T		

Device	Bit Address	Word Address	Controller Setting item	Identifier	other
00_	005000 ~ 005015	0050	Abnormal SV/heater function	E1B	
	005100 ~ 005115	0051	EV 1, polarity	E1P	
	005200 ~ 005215	0052	CT input	CM1	
	005300 ~ 005315	0053	EV 1, abnormal current of heater	CT1	
	005400 ~ 005415	0054	EV 2, function	E2F	
	005500 ~ 005515	0055	EV 2, H limit	E2H	
	005600 ~ 005615	0056	EV 2, L limit	E2L	
	005700 ~ 005715	0057	EV 2, sensitivity	E2C	
	005800 ~ 005815	0058	EV 2, delay timer	E2T	
	005900 ~ 005915	0059	EV 2, abnormal SV/ heater function	E2B	
	006000 ~ 006015	0060	EV 2, polarity	E2P	
	006100 ~ 006115	0061	CT input	CM2	
	006200 ~ 006215	0062	EV 2, abnormal current of heater	CT2	
	006300 ~ 006315	0063	DI input	DIF	
	006400 ~ 006415	0064	Polarity of DI	DIP	
	006500 ~ 006515	0065	Control setting 2	SV2	
	006600 ~ 006615	0066	Timer output	TMO	
	006700 ~ 006715	0067	Timer function	TMF	
	006800 ~ 006815	0068	Timer unit switch	H/M	
	006900 ~ 006915	0069	Allowable width for timer SV start	TSV	
	007000 ~ 007015	0070	Time setting	TIM	
	007100 ~ 007115	0071	Monitor of remaining time	TIA	
	_____	0072	Timer start/stop	TST	<input type="checkbox"/>
	007300 ~ 007315	0073	Output monitor	OM1	
	007400 ~ 007415	0074	AT start/stop	<input type="checkbox"/> AT	
	_____	0075	Data store	STR	<input type="checkbox"/>

■ TTM-10L

Device	Bit Address	Word Address	Control Setting Item	Identifier	Other
10_	000000 ~ 000015	0000	Process Variable (PV)	PV1	
	000100 ~ 000115	0001	Control Setting Value (SV)	<input type="checkbox"/> SV	
	000200 ~ 000215	0002	EV L. Limit Set	1L1	
	000300 ~ 000315	0003	EV H. Limit Set	1H1	
	000400 ~ 000415	0004	Auto-Tuning Start/Release	<input type="checkbox"/> AT	
	000500 ~ 000515	0005	Proportional Band	<input type="checkbox"/> P1	
	000600 ~ 000615	0006	Integral Time	<input type="checkbox"/> I1	
	000700 ~ 000715	0007	Derivative Time	<input type="checkbox"/> D1	
	000800 ~ 000815	0008	P-cycle Time	<input type="checkbox"/> T1	
	000900 ~ 000915	0009	Control Sensitivity	<input type="checkbox"/> C1	
	001000 ~ 001015	0010	Set/Select of Input/Output	<input type="checkbox"/> IO	
	001100 ~ 001115	0011	L. Limit of SV Limiter	SLL	
	001200 ~ 001215	0012	H. Limit of SV Limiter	SLH	
	001300 ~ 001315	0013	Control Type	CNT	
	001400 ~ 001415	0014	PV Correction	PVS	
	001500 ~ 001515	0015	Manual Reset	PBB	
	001600 ~ 001615	0016	OFF Position	<input type="checkbox"/> CP	
	001700 ~ 001715	0017	EV Function	A1F	
	001800 ~ 001815	0018	EV Sensitivity	ALC	
	001900 ~ 001915	0019	Decimal Point Position	<input type="checkbox"/> DP	
	002000 ~ 002015	0020	Selection of C/F	<input type="checkbox"/> CF	
	002100 ~ 002115	0021	Setting of Lock Function	LOC	
	002200 ~ 002215	0022	Temperature of cooling contact compensation	<input type="checkbox"/> CJ	
	002300 ~ 002315	0023	Process Variable (PV) with decimal point	PV2	
	002400 ~ 002415	0024	Output state monitor	OM1	
_____	0025	Data store	STR	<input type="checkbox"/>	

■ TTM-110Series (TTM-114, 115, 117, 119)/110B

Device	Bit Address	Word Address	Controll Setting Item	PV	Other
10_	000000 ~ 000015	0000	Process value (PV)	PV1	
	000100 ~ 000115	0001	Control set value (SV)	<input type="checkbox"/> SV	
	000200 ~ 000215	0002	Main control MV (OUT1)	MV1	
	000300 ~ 000315	0003	Main control MV (OUT2)	MV2	
	000400 ~ 000415	0004	Auto-tuning start/release	<input type="checkbox"/> AT	
	000500 ~ 000515	0005	Alarm 1 L limit set	1L1	
	000600 ~ 000615	0006	Alarm 1 H limit set	1H1	
	000700 ~ 000715	0007	Main control P-band	<input type="checkbox"/> P1	
	000800 ~ 000815	0008	Integral time	<input type="checkbox"/> I1	
	000900 ~ 000915	0009	Derivative time	<input type="checkbox"/> D1	
	001000 ~ 001015	0010	Output 1 P-cycle time	<input type="checkbox"/> T1	
	001100 ~ 001115	0011	Output 1 sensitivity	<input type="checkbox"/> C1	
	001200 ~ 001215	0012	Output 2 P-band	PC1	
	001300 ~ 001315	0013	Output 2 P-cycle time	TC1	
	001400 ~ 001415	0014	Output 2 sensitivity	CC1	
	001500 ~ 001515	0015	Dead Band	DB1	
	001600 ~ 001615	0016	Cooling Point of Contact Compensation	<input type="checkbox"/> CJ	
	001700 ~ 001715	0017	Set/Select of Input/Output	<input type="checkbox"/> IO	
	001800 ~ 001815	0018	Setting of L limit for OUT1 MV Limiter	MLL	
	001900 ~ 001915	0019	Setting of H limit for OUT1 MV Limiter	MLH	
	002000 ~ 002015	0020	Setting of L limit of SV Limiter	SLL	
	002100 ~ 002115	0021	Setting of H limit of SV Limiter	SLH	
	002200 ~ 002215	0022	Control action select	CNT	
	002300 ~ 002315	0023	Setting of sensor value correction	PVS	
	002400 ~ 002415	0024	Manual reset value	PBB	
	002500 ~ 002515	0025	Alarm 1 function	A1F	
	002600 ~ 002615	0026	AL output sensitivity	ALC	
	002700 ~ 002715	0027	Heater abnormal current	<input type="checkbox"/> CT	
	002800 ~ 002815	0028	Selection of data transmission function	TR1	
	002900 ~ 002915	0029	Selection of C/F	<input type="checkbox"/> CF	
	003000 ~ 003015	0030	Output state monitor	OM1	
	003100 ~ 003115	0031	Response Delay Speed	AWT	
_____	0032	Data store	STR		

■TTM-110Series(TTM-114, 115, 117, 119)/110B

Device	Bit Address	Word Address	Controller Setting Item	Identifier	Other
110_	000000 ~ 000015	0000	Process Value (PV)	PV1	
	000100 ~ 000115	0001	Control Set Value (SV)	<input type="checkbox"/> SV	
	000200 ~ 000215	0002	Main Control MV (OUT 1)	MV1	
	000300 ~ 000315	0003	Sub-Control MV (OUT 2)	MV2	
	000400 ~ 000415	0004	Timer Remainder Time	TIA	
	000500 ~ 000515	0005	Auto-Tuning Start/Release	<input type="checkbox"/> AT	
	000600 ~ 000615	0006	Time Setting On Timer	TIM	
	000700 ~ 000715	0007	Alarm 1 L. Limit Set	1L1	
	000800 ~ 000815	0008	Alarm 1 H. Limit Set	1H1	
	000900 ~ 000915	0009	Alarm 2 L. Limit Set	2L1	
	001000 ~ 001015	0010	Alarm 2 H. Limit Set	2H1	
	001100 ~ 001115	0011	Main Control P-band	<input type="checkbox"/> P1	
	001200 ~ 001215	0012	Integral Time	<input type="checkbox"/> I1	
	001300 ~ 001315	0013	Derivative Time	<input type="checkbox"/> D1	
	001400 ~ 001415	0014	Output 1 P-cycle Time	<input type="checkbox"/> T1	
	001500 ~ 001515	0015	Output 1 Sensitivity	<input type="checkbox"/> C1	
	001600 ~ 001615	0016	Output 2 P-band	PC1	
	001700 ~ 001715	0017	Output 2 P-cycle Time	TC1	
	001800 ~ 001815	0018	Output 2 Sensitivity	CC1	
	001900 ~ 001915	0019	Dead Band	DB1	
	002000 ~ 002015	0020	Set/Select of Input/Output Type	<input type="checkbox"/> IO	
	002100 ~ 002115	0021	Setting of L. Limit For Out 1 MV Limiter	MLL	
	002200 ~ 002215	0022	Setting of H. Limit For Out 1 MV Limiter	MLH	
	002300 ~ 002315	0023	Setting of H. Limit of SV Limiter	SLL	
	002400 ~ 002415	0024	Setting of L. Limit of SV Limiter	SLH	
	002500 ~ 002515	0025	Control Action Select	CNT	
	002600 ~ 002615	0026	Setting of Sensor Value Correction	PVS	
	002700 ~ 002715	0027	Manual Reset Value	PBB	
	002800 ~ 002815	0028	Timer Operation Mode	TMM	
	002900 ~ 002915	0029	Alarm 1 Function	A1F	
	003000 ~ 003015	0030	Alarm 2 Function	A2F	
	003100 ~ 003115	0031	AL Output Sensitivity	ALC	
	003200 ~ 003215	0032	Heater Abnormal Current	<input type="checkbox"/> CT	
	003300 ~ 003315	0033	Selection of Data Transmission Function	TR1	
	003400 ~ 003415	0034	Decimal Point Position	<input type="checkbox"/> DP	
	003500 ~ 003515	0035	Selection of C/F	<input type="checkbox"/> CF	
	003600 ~ 003615	0036	Buzzer Sound Setting	<input type="checkbox"/> BU	
	003700 ~ 003715	0037	Setting of Lock Function	LOC	
	003800 ~ 003815	0038	Output State Monitor	OM1	
	—————	0039	Timer Reset	TMS	<input type="checkbox"/> 1.5
	004000 ~ 004015	0040	Run/Ready Status	RUN	
—————	0041	Data Store	STR	<input type="checkbox"/> 1.5	

■ TTM-120 Series (TTM-124, 125, 127, 129)

Device	Bit Address	Word Address	Controller Setting Item	Identifier	Other
120_	000000 ~ 000015	0000	Process Value (PV)	PV1	
	000100 ~ 000115	0001	Control Set Value (SV)	<input type="checkbox"/> AV	
	000200 ~ 000215	0002	Control Mode	MD1	
	000300 ~ 000315	0003	Main Control MV (OUT1)	MV1	
	000400 ~ 000415	0004	Sub-Control MV (OUT2)	MV2	
	000500 ~ 000515	0005	Auto-Tuning Start/Release	<input type="checkbox"/> AT	
	000600 ~ 000615	0006	Alarm 1L Limit Set	1L1	
	000700 ~ 000715	0007	Alarm 1H Limit Set	1H1	
	000800 ~ 000815	0008	Alarm 2L Limit Set	2L1	
	000900 ~ 000915	0009	Alarm 2H Limit Set	2H1	
	001000 ~ 001015	0010	Output 1 P-band	<input type="checkbox"/> P1	
	001100 ~ 001115	0011	Integral Time	<input type="checkbox"/> I1	
	001200 ~ 001215	0012	Derivative Time	<input type="checkbox"/> D1	
	001300 ~ 001315	0013	Output 1 P-cycle Time	<input type="checkbox"/> T1	
	001400 ~ 001415	0014	Output 1 Sensivity	<input type="checkbox"/> C1	
	001500 ~ 001515	0015	Main Control OFF Position	<input type="checkbox"/> CP	
	001600 ~ 001615	0016	Output 2 P-band	PC1	
	001700 ~ 001715	0017	Output 2 P-cycle Time	TC1	
	001800 ~ 001815	0018	Output 2 Sensivity	CC1	
	001900 ~ 001915	0019	Output 2 OFF Position	CCP	
	002000 ~ 002015	0020	Dead Band	DB1	
	002100 ~ 002115	0021	Set/Select of Input/Output Type	<input type="checkbox"/> IO	
	002200 ~ 002215	0022	Setting of L. Limit for Out1 MV Limiter	MLL	
	002300 ~ 002315	0023	Setting of H. Limit for Out1 MV Limiter	MLH	
	002400 ~ 002415	0024	Setting of L. Limit of SV Limiter	SLL	
	002500 ~ 002515	0025	Setting of H. Limit of SV Limiter	SLH	
	002600 ~ 002615	0026	Control Action Select	CNT	
	002700 ~ 002715	0027	Rump Time of SV1	RP1	
	002800 ~ 002815	0028	Setting of Sensor Value correction	PVS	
	002900 ~ 002915	0029	Digital PV Filter	PDF	
	003000 ~ 003015	0030	Manual Reset Value	PBB	
	003100 ~ 003115	0031	Swiching for Balanceless Bumpless	<input type="checkbox"/> BB	
	003200 ~ 003215	0032	Alarm 1 Function	A1F	
	003300 ~ 003315	0033	Alarm 2 Function	A2F	
	003400 ~ 003415	0034	AL Output Sensivity	ALC	
	003500 ~ 003515	0035	Heater Abnormal Current	<input type="checkbox"/> CT	
	003600 ~ 003615	0036	Selection of Data Transmission Function	TR1	
	003700 ~ 003715	0037	DI Function	<input type="checkbox"/> DI	
	003800 ~ 003815	0038	Decimal Point Position	<input type="checkbox"/> DP	
	003900 ~ 003915	0039	Selection of C/F	<input type="checkbox"/> CF	
	004000 ~ 004015	0040	Buzzer Sound Setting	<input type="checkbox"/> BU	
	004100 ~ 004115	0041	Setting of Lock	LOC	
	004200 ~ 004215	0042	Output State Monitor	OM1	
	—————	0043	Data Store	STR	

■TTM-300 Series (TTM-304, 305, 309)/300B

Device	Bit Address	Word Address	Controller Setting Item	Identifier	Other
300_	000000 ~ 000015	0000	Process Value (PV)	PV1	
	000100 ~ 000115	0001	Mode change	<input type="checkbox"/> MD	
	000200 ~ 000215	0002	Control Setting Value (SV)	<input type="checkbox"/> SV	
	000300 ~ 000315	0003	Run Step Setting Value (SV)	OSV	
	000400 ~ 000415	0004	The time elapsed	<input type="checkbox"/> TI	
	000500 ~ 000515	0005	Run step setting time	OTI	
	000600 ~ 000615	0006	Count numbers of time executed	SRR	
	—————	0007	Step forward function execution	ADV	<input type="checkbox"/> [Bit 5]
	000800 ~ 000815	0008	Pattern number	<input type="checkbox"/> PT	
000900 ~ 000915	0009	Step number	<input type="checkbox"/> ST		
SSV	000000 ~ 204715	0000 ~ 2047 ^{*1}	Step temperature setting	SSV	
END	000000 ~ 204715	0000 ~ 2047 ^{*1}	Final step setting	END	
STI	000000 ~ 204715	0000 ~ 2047 ^{*1}	Step time setting	STI	
SOK	000000 ~ 204715	0000 ~ 2047 ^{*1}	Final step finish condition setting	SOK	
SWZ	000000 ~ 204715	0000 ~ 2047 ^{*1}	Step wait zone	SWZ	
SWT	000000 ~ 204715	0000 ~ 2047 ^{*1}	Step wait time	SWT	
SON	000000 ~ 204715	0000 ~ 2047 ^{*1}	Time signal ON time	SON	
SOF	000000 ~ 204715	0000 ~ 2047 ^{*1}	Time signal OFF time	SOF	
SRN	000000 ~ 200015	0000 ~ 2000 ^{*2}	Execution time	SRN	
SEO	000000 ~ 200015	0000 ~ 2000 ^{*2}	End signal ON time	SEO	
300_	001000 ~ 001015	0010	Pattern numbers	PAT	
	001100 ~ 001115	0011	Step numbers	STP	
	001200 ~ 001215	0012	PV correction	PVS	
	001300 ~ 001315	0013	Change C/ F	<input type="checkbox"/> CF	
	001400 ~ 001415	0014	Type of Control	CNT	
	001500 ~ 001515	0015	Type of Input/Output	<input type="checkbox"/> IO	
	001600 ~ 001615	0016	Select decimal position	<input type="checkbox"/> DP	
	001700 ~ 001715	0017	Mainipulated value limiter Low	MLL	
	001800 ~ 001815	0018	Manipulated value limiter High	MLH	
	001900 ~ 001915	0019	Setting of L. limit of SV limiter	SLL	
	002000 ~ 002015	0020	Setting of H. limit of SV limiter	SLH	
	002100 ~ 002115	0021	Select PV start or SV start	PSV	
	002200 ~ 002215	0022	SV start setting value	SVS	
	002300 ~ 002315	0023	Select Start at Power ON	PON	
	002400 ~ 002415	0024	Event Output 1 function	DO1	
	002500 ~ 002515	0025	PV Event Output 1 function	A1F	
	002600 ~ 002615	0026	Event Output 1 Low limit	A1L	
	002700 ~ 002715	0027	Event Output 1 High limit	A1H	
	002800 ~ 002815	0028	Event Output 1 sensitivity	A1C	
	002900 ~ 002915	0029	Time signal 1 Output mode	TF1	
	003000 ~ 003015	0030	Time signal 1 ON time	ON1	
003100 ~ 003115	0031	Time signal 1 OFF time	OF1		
003200 ~ 003215	0032	Event output 1 unusual looping time	LT1		
003300 ~ 003315	0033	Event Output 2 function	DO2		
003400 ~ 003415	0034	PV Event Output 2 function	A2F		
003500 ~ 003515	0035	Event Output 2 Low limit	A2L		

Device	Bit Address	Word Address	Controller Setting Item	Identifier	Other
300-	003600 ~ 003615	0036	Event Output 2 High limit	A2H	
	003700 ~ 003715	0037	Event Output 2 sensitivity	A2C	
	003800 ~ 003815	0038	Time signal 2 Output mode	TF2	
	003900 ~ 003915	0039	Time signal 2 ON time	ON2	
	004000 ~ 004015	0040	Time signal 2 OFF time	OF2	
	004100 ~ 004115	0041	Event output 2 unusual looping time	LT2	
	004200 ~ 004215	0042	Key lock function	LOC	
	004300 ~ 004315	0043	Output condition monitor	OM1	
	004400 ~ 004415	0044	[Low temperature] Proportional	<input type="checkbox"/> P1	
	004500 ~ 004515	0045	[Low temperature] Integrated time	<input type="checkbox"/> I1	
	004600 ~ 004615	0046	[Low temperature] Differential time	<input type="checkbox"/> D1	
	004700 ~ 004715	0047	Middle point 1 setting	PM1	
	004800 ~ 004815	0048	[Middle temperature] Proportional	<input type="checkbox"/> P2	
	004900 ~ 004915	0049	[Middle temperature] Integrated	<input type="checkbox"/> I2	
	005000 ~ 005015	0050	[Middle temperature] Differential	<input type="checkbox"/> D2	
	005100 ~ 005115	0051	Middle point 2 setting	PM2	
	005200 ~ 005215	0052	[High temperature] Proportional	<input type="checkbox"/> P3	
	005300 ~ 005315	0053	[High temperature] Integrated time	<input type="checkbox"/> I3	
	005400 ~ 005415	0054	[High temperature] Differential time	<input type="checkbox"/> D3	
	005500 ~ 005515	0055	Proportional Cycle	<input type="checkbox"/> <input type="checkbox"/> T	
	005600 ~ 005615	0056	Fuzzy constant	FUZ	
	005700 ~ 005715	0057	Control sensitivity to [Low temperature]	<input type="checkbox"/> C1	
	005800 ~ 005815	0058	Control sensitivity to [Middle temperature]	<input type="checkbox"/> C2	
	005900 ~ 005915	0059	Control sensitivity to [High temperature]	<input type="checkbox"/> C3	
	006000 ~ 006015	0060	Auto-tuning setting value of [High temperature]	AT1	
	006100 ~ 006115	0061	Auto-tuning setting value of [Middle temperature]	AT2	
	006200 ~ 006215	0062	Auto-tuning setting value of [High temperature]	AT3	
	_____	0063	Auto-tuning execution of [Low temperature]	AP1	<input type="checkbox"/>
	_____	0064	Auto-tuning execution of [Middle temperature]	AP2	<input type="checkbox"/>
	_____	0065	Auto-tuning execution of [High temperature]	AP3	<input type="checkbox"/>
_____	0066	Auto-tuning execution of [Low]->[Middle]->[High] temperature	AP4	<input type="checkbox"/>	
006700 ~ 006715	0067	Auto-tuning under execution	ATR		

*1 When using identifiers from SSV to SOF with a TTM-300 series unit, use the Device Name as the identifier, and the Step No. and Pattern No. as the address. The maximum values available for the pattern number and the step number that can be set on a GP/GLC/LT are 20 and 47, respectively. Specify them as shown below.

Ex.)

Device	Bit Address	Word Address	Control Setting Item	Identifier
SSV	000000 ~ 204715	0000 ~ 2047	Step Temperature Setting	SSV

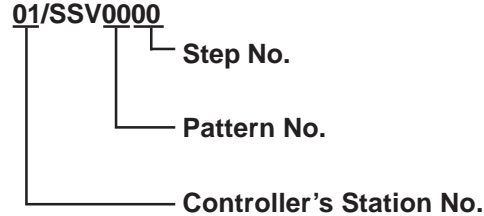

*2 When using identifier SRN or SEO with the TTM-300 series unit, use the Device Name as the identifier, and the Step No. and Pattern No. as the address. The maximum values available for the pattern number and the step number that can be set on a GP/GLC/LT is 20, respectively. Specify them as shown below.

Ex.)

Device	Bit Address	Word Address	Controller Setting Item	Identifier
SRN	000000 ~ 200015	0000 ~ 2000	Excution Time	SRN

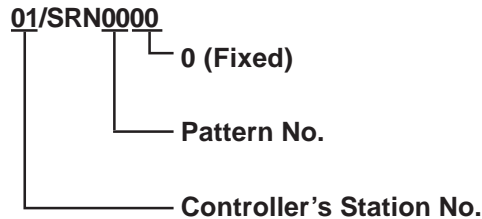

When entering addresses for identifiers SSV to SEO with a TTM-300 series unit, be sure to refer *1 or *2 above.

Device Selection

(Select from SSV, END, STI, SOK, SWZ, SWT, SON, SOF, SRN or SEO)

Address Selection
(Step No. or Pattern No.)

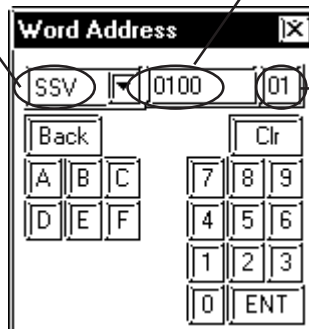

Enter the Controller's Station No.

■ TTM-1020 Series(TTM-1520, 1521, 1522, 1523, 1524, 1525, 1920, 1921, 1922, 1923, 1924, 1925)

Device	Bit Address	Word Address	Controller Setting Item	Identifier	Other
1020_	000000 - 000015	0000	Process Value (PV)	PV1	
	000100 - 000115	0001	CH No.	<input type="checkbox"/> CH	
	000200 - 000215	0002	Control Setting Value (SV)	<input type="checkbox"/> SV	
	000300 - 000315	0003	SV1	SV1	
	000400 - 000415	0004	Set/Select of Auto/Manual	MD1	
	000500 - 000515	0005	Set/Select of Remote/Local	REM	
	000600 - 000615	0006	Main Control MV (Out 1)	MV1	
	000700 - 000715	0007	Main Control MV (Out 2)	MV2	
	000800 - 000815	0008	Auto-Tuning Start/Release	<input type="checkbox"/> AT	
	000900 - 000915	0009	SV2	SV2	
	001000 - 001015	0010	SV3	SV3	
	001100 - 001115	0011	SV4	SV4	
	001200 - 001215	0012	SV5	SV5	
	001300 - 001315	0013	SV6	SV6	
	001400 - 001415	0014	SV7	SV7	
	001500 - 001515	0015	SV8	SV8	
	001600 - 001615	0016	Set/Select of Input/Output Type	<input type="checkbox"/> IO	
	001700 - 001715	0017	Setting of Sensor Value Correction	PVS	
	001800 - 001815	0018	Decimal Point Position	<input type="checkbox"/> DP	
	001900 - 001915	0019	Selection of C/F	<input type="checkbox"/> CF	
	002000 - 002015	0020	Setting of L. Limit of SV Limiter	SLL	
	002100 - 002115	0021	Setting of H.Limit of SV Limiter	SLH	
	002200 - 002215	0022	Setting of Lock Function	LOC	
	002300 - 002315	0023	Control Action Select	CNT	
	002400 - 002415	0024	Proportional band	<input type="checkbox"/> P1	
	002500 - 002515	0025	Integrated time	<input type="checkbox"/> I1	
	002600 - 002615	0026	Differential time	<input type="checkbox"/> D1	
	002700 - 002715	0027	Output 1 P-cycle Time	<input type="checkbox"/> T1	
	002800 - 002815	0028	Control sensitivity	<input type="checkbox"/> C1	
	002900 - 002915	0029	Manual Reset Value	PBB	
	003000 - 003015	0030	Setting of L. Limit for Out 1 MV Limiter	MLL	
	003100 - 003115	0031	Setting of H. Limit for Out 1 MV Limiter	MLH	
	003200 - 003215	0032	Setting for unusual	FAL	
	003300 - 003315	0033	Cooling P-band	PC1	
	003400 - 003415	0034	Cooling P-cycle time	TC1	
	003500 - 003515	0035	Cooling Sensitivity	CC1	
	003600 - 003615	0036	Dead Band	DB1	
	003700 - 003715	0037	Setting of L limit of cooling output	MCL	
	003800 - 003815	0038	Setting of H limit of cooling output	MCH	
003900 - 003915	0039	L limit of cascade scaling	CSL		

Device	Bit Address	Word Address	Controll Setting Item	Identifier	Other
1020_	004000 ~ 004015	0040	H limit of cascade scalling	CSH	
	004100 ~ 004115	0041	Event 1 Function	EV1	
	004200 ~ 004215	0042	PV Event 1 Function	P1F	
	004300 ~ 004315	0043	PV Event 1 Low Limit	P1L	
	004400 ~ 004415	0044	PV Event 1 High Limit	P1H	
	004500 ~ 004500	0045	DI 1 Function	D1F	
	004600 ~ 004615	0046	Event 2 Function	EV2	
	004700 ~ 004715	0047	PV Event 2 Function	P2F	
	004800 ~ 004815	0048	PV Event 2 Low Limit	P2L	
	004900 ~ 004915	0049	PV Event 2 High Limit	P2H	
	005000 ~ 005015	0050	DI2 Function	D2F	
	005100 ~ 005115	0051	Event 3 Function	EV3	
	005200 ~ 005215	0052	PV Event 3 function	P3F	
	005300 ~ 005315	0053	PV Event 3 Low Limit	P3L	
	005400 ~ 005415	0054	PV Event 3 Hight Limit	P3H	
	005500 ~ 005515	0055	DI3 Function	D3F	
	005600 ~ 005615	0056	Event 4 Function	EV4	
	005700 ~ 005715	0057	PV Event 4 Function	P4F	
	005800 ~ 005815	0058	PV Event 4 Low Limit	P4L	
	005900 ~ 005915	0059	PV Event 4 High Limit	P4H	
	006000 ~ 006015	0060	DI4 Function	D4F	
	006100 ~ 006115	0061	Evet 5 Function	EV5	
	006200 ~ 006215	0062	PV Event 5 Function	P5F	
	006300 ~ 006315	0063	PV Event 5 Low Limit	P5L	
	006400 ~ 006415	0064	PV Event 5 High Limit	P5H	
	006500 ~ 006515	0065	DI5 Function	D5F	
	006600 ~ 006615	0066	Selection of Data Transmission 1 Function	TR1	
	006700 ~ 006715	0067	L limit of transmission 1 scalling	T1L	
	006800 ~ 006815	0068	H limit of transmission 2 scalling	T1H	
	006900 ~ 006915	0069	Selection of Data Transmission 2 Function	TR2	
	007000 ~ 007015	0070	L limit of transmission 2 scalling	T2L	
	007100 ~ 007115	0071	H limit of transmission 2 scalling	T2H	
007200 ~ 007215	0072	Close feedback resistance control	CLS		
007300 ~ 007315	0073	Open feedback resistance control	OPN		
007400 ~ 007415	0074	quota of function	FNC		
007500 ~ 007515	0075	Output State Monitor	OM1		
007600 ~ 007615	0076	Event condition monitor	EM1		
_____	0077	Data Store	STR		

12.8.4 Environment Setup

The following table lists the recommended Controller and GP/GLC/LT communication settings.

GP/GLC/LT Settings		Controller Settings	
Baud Rate	9600 bps	Baud Rate	9600 bps
Data Length	8 bit	Data Length	8 bit
Stop Bit	2 bit	Stop Bit	2 bit
Parity Bit	None	Parity Bit	None
Data Flow Control	ER	_____	_____
Communication Format (using RS-422) *1	RS-422 (2-line)	_____	_____
Communication Format (using RS-232C) *1	RS-232C	_____	_____
Unit No. *2	1 to 32	Communication Unit No.	1 to 32
_____	_____	Mode Setting *3	Communication Mode
_____	_____	Mode Setting *4	Read/Write

- *1 Controller cannot switch the Communication Format. When purchasing the Controller, select either an RS-422 or RS-232C.
- *2 Although the settable range for a machine number on the temperature controllers is 1 to 99, the range for GP/GLC is 1 to 32.
- *3 This setting is required for models other than the TTM-004/X04 series. When you perform communication between the Controller and GP/GLC/LT, be sure to set your Controller to Data Transfer mode.
- *4 This setting is required only for the TTM-004/X04 series. When the Controller is set to read-only, rewritable devices will become read-only.

12.8.5 Error Code

Controller error codes are displayed by the “Host Communication Error (02:**:##)”, and indicated in the left lower corner of the GP/GLC/LT screen ** indicates the Controller’s error code, and ## indicates the number of the Controller unit.

Error Code	Error Message	Meaning
00	Flat of the instrument (Memory error or A/D conversion error)	_____
01	Numeric data out of "the setting range respectively specified in each of setting items".	Data written to an arbitrary device is out of the range for writing.
02	Change of an item prohibited, or no item to be read out.	No device exists in the address specified for the temperature controller connected to GLC/GP/LT. Or, data was written to the specified device, even though that device is write protected.
03	An ASCII code other than the numeric data is specified in the place. Or, an ASCII code other than "0" or "-" is specified in the place for the sign.	_____
04	Format error	The format of the command from the GP/GLC/LT is incorrect due to noise, etc.
05	BCC error	The format of commands sent from GP/GLC/LT is erroneous due to noise or the like.
06	Overrun error	_____
07	Framing error	Machine Numbers for temperature controllers are overlapping. Or, the format of commands sent from GP/GLC/LT is erroneous due to noise or the like.
08	Parity error	The current Data Transfer Parity setting is incorrect. Or, the format of commands sent from GP/GLC/LT is erroneous due to noise or the like.
09	Trouble has happened on PV in process of AT. Or, AT does not be finalized in 3 hours.	_____



Depending on the specification of the Controller, if two errors occur at the same time, the larger error number will be displayed.

Reference

For more details about error codes, refer to the TOHO ELECTRONICS INC.'s COMMUNICATIONS FUNCTION Instructon Manual.

