

Device/PLC Connection Manuals



About the Device/PLC Connection Manuals

Prior to reading these manuals and setting up your device, be sure to read the "Important: Prior to reading the Device/PLC Connection manual" information. Also, be sure to download the "Preface for Trademark Rights, List of Units Supported, How to Read Manuals and Documentation Conventions" PDF file. Furthermore, be sure to keep all manual-related data in a safe, easy-to-find location.

5.2 OMRON

5.2.1 System Structure



The following describes the system structure for connecting the GP to Omron PLCs.

Reference The Cable Diagrams mentioned in the following tables are listed in the section titled "5.2.2 Cable Diagrams".



If the SYSMAC C/CV/α series PLC is used in RUN mode, "PLC COM. ERROR (02: 01)" may briefly display. The GP subsequently forces the PLC to enter the MONITOR mode (data can be written to the PLC, while it is in RUN mode); data communication will not be affected.

■ SYSMAC C Series (using Link I/F)

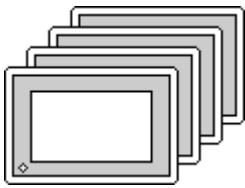
CPU	Link I/F	Cable Diagram	GP
	 Upper Link Unit		
C 200H	C 200H-LK202 ^{*1} C 120-LK202-V1 ^{*2}	RS-422 (Cable Diagram 1)	GP Series
C 200HS	C 200H-LK202 ^{*1}	RS-422 (Cable Diagram 2)	
C 500, C 500F, C 1000H, C 2000,	C 120-LK202-V1 ^{*2} C 500-LK201-V1 ^{*1}		
C 2000H	C 500-LK203 ^{*1}	RS-422 (Cable Diagram 1)	
C 1000HF	C 500-LK203 ^{*1}		
C 120, C 120F	C 120-LK202-V1 ^{*2}	RS-422 (Cable Diagram 5)	
SRM1-C02 CPM1-20CDR-A CPM2A	CPM1-CIF11		



* 1 Base installation type.

* 2 Connected to the CPU.



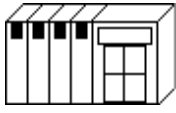
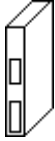

When you wish to run communications at a high speed, use the upper Link I/F (CPU type) C120-LK202-V1.

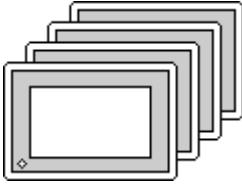

■ **SYSMAC- α Series** (using Link I/F)

CPU	Link I/F	Cable Diagram	GP
	Communication Board 		
C200HX-CPU64, C200HG-CPU43, C200GE-CPU42	C200HW-COM06	RS-422 (Cable Diagram 3)	GP series
C200HX-CPU64-Z	C200H-LK202-V1	RS-422 (Cable Diagram 1)	

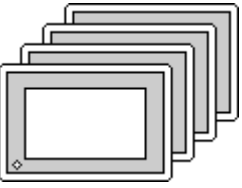

■ **SYSMAC CV Series** (using Link I/F and CPU Unit Link I/F)

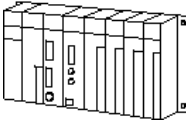
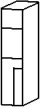
CPU	Link I/F	Cable Diagram	GP
	Communication Board 		
CV500, CV1000, CVM1	CV500-LK201 CPU Unit Link I/F	RS-422 (Cable Diagram 4)	GP series

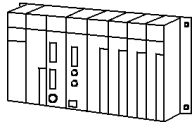

■ **SYSMAC CJ1M Series** (using Link I/F)

CPU	Link I/F	Cable Diagram	GP
			
CJ1M-CPU23 CJ1M-CPU22 CJ1M-CPU13 CJ1M-CPU12	CJ1W-SCU41	RS-422 (Cable Diagram 6)	GP Series

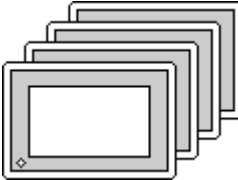
■ **SYSMAC CS1 Series** < using Link I/F >

CPU	Link I/F	Cable Diagram	GP
			
CS1H-CPU67 CS1H-CPU66 CS1H-CPU65 CS1H-CPU64 CS1H-CPU63 CS1G-CPU45 CS1G-CPU44 CS1G-CPU43 CS1G-CPU42 CS1H-CPU67H CS1H-CPU66H CS1H-CPU65H CS1H-CPU64H CS1H-CPU63H CS1G-CPU45H CS1G-CPU44H CS1G-CPU43H CS1G-CPU42H	CS1W-SCB41	RS-422 (Port 2) (Cable Diagram 6)	GP Series

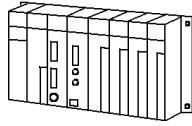
■ **SYSMAC CJ Series** (using Link I/F)

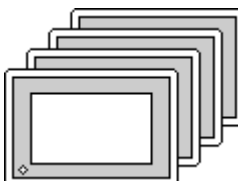
CPU	Link I/F	Cable Diagram	GP
			
CJ1G-CPU44 CJ1G-CPU45 CJ1G-CPU42H CJ1G-CPU43H CJ1G-CPU44H CJ1G-CPU45H	CJ1W-SCU41	RS-422 (Cable Diagram 6)	GP series

5.2.2 Cable Diagrams

The cable diagrams shown below and the cable diagrams recommended by Omron may differ, however, using these cables for your PLC operations will not cause any problems.

Cable Diagram 1

- When using Digital's RS-422 connector terminal adapter GP070-CN10-O

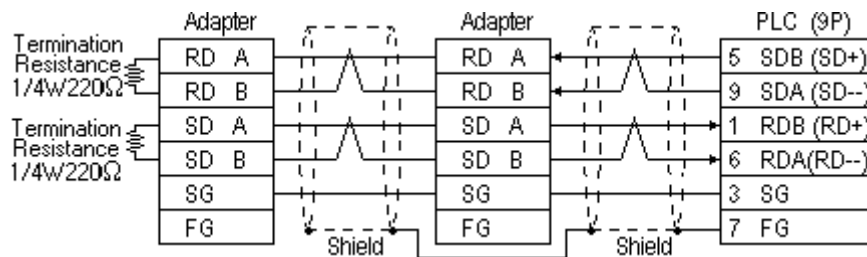

- When using Digital's Multi-link Cable, GP230-IS12-O

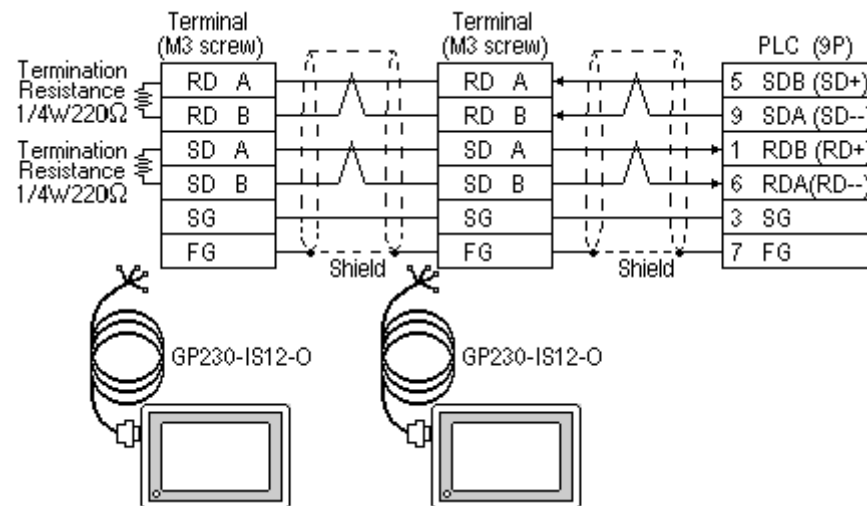

Ground your PLC's FG terminal according to your country's applicable standard. For details, refer to the corresponding PLC manual.



- **Pull out a small amount of the Transfer Cable's shield, make a wire out of it and connect it to the PLC's FG terminal.**
- **The GP230-IS12-O Cable FG terminal is not connected to the GP's FG.**
- **Be aware the A and B signals of the GP and PLC are opposite to each other.**
- **Place a Termination Resistor where the GP and PLC are positioned at either end of the cable. The Termination Resistor is automatically setup when the PLC's Termination Resistor switch is turned ON.**



- For the RS-422 connection, use a cable length less than 500m.
- As a general rule, connect the PLC at either end of the circuit.

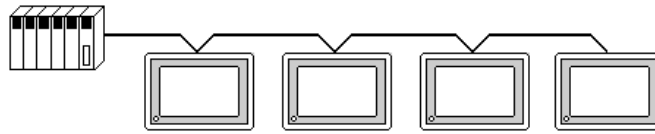

When making your own cable connections, we recommend using Hirakawa Densen's H-9293A (CO-HC-ESV-3P*7/0.2).

The cable connection lines are as illustrated below. The cables between the GP and the terminals should be less than 10 meters.

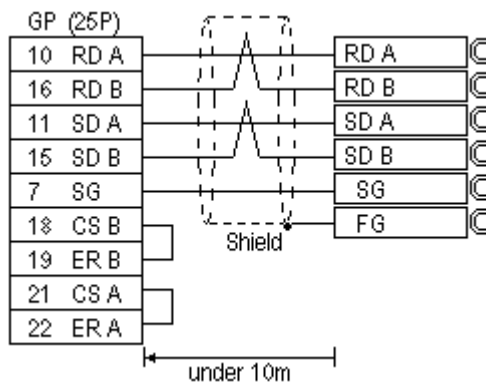

Cable Diagram 2

- When using Digital's RS-422 connector terminal adapter GP070-CN10-O

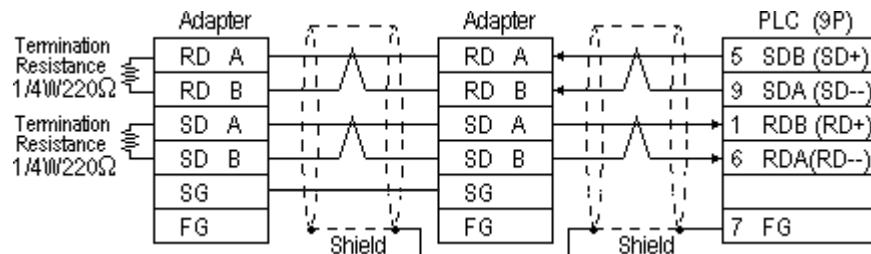

- When using Digital's Multi-link Cable, GP230-IS12-O

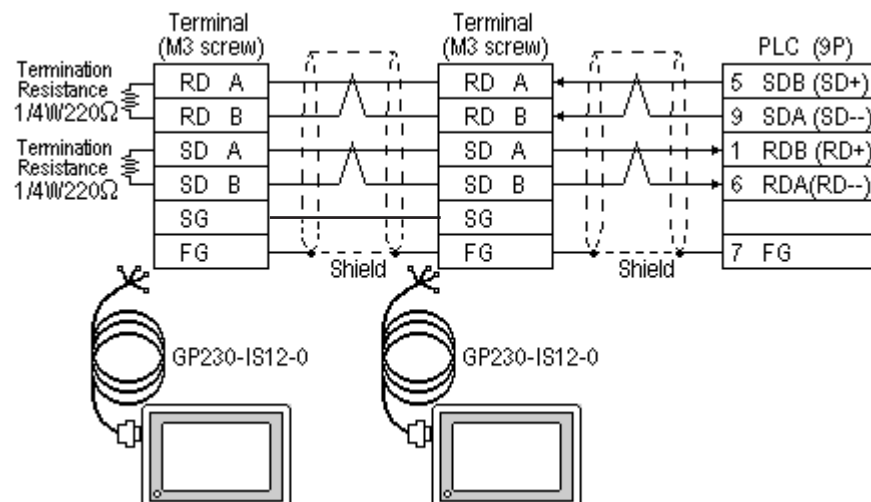



Ground your PLC's FG terminal according to your country's applicable standard. For details, refer to the corresponding PLC manual.



- Pull out a small amount of the Transfer Cable's shield, make a wire out of it and connect it to the PLC's FG terminal.
- The GP230-IS12-O Cable FG terminal is not connected to the GP's FG.
- Be aware the A and B signals of the GP and PLC are opposite to each other.
- Place a Termination Resister at both ends of the cable. The termination Resister is automatically setup when the PLC's Termination Resister switch is turned ON.
- As a general rule, connect the PLC at either end of the circuit.

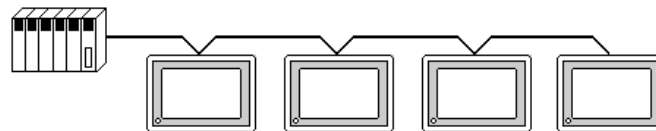

When making your own cable connections, we recommend using Hiramaka Densen's H-9293A (CO-HC-ESV-3P*7/0.2).

The cable connection lines are as illustrated below. The cables between the GP and the terminals should be less than 10 meters.

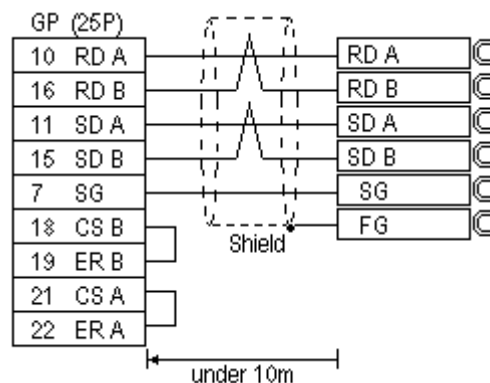

Cable Diagram 3

- When using Digital's RS-422 connector terminal adapter GP070-CN10-O

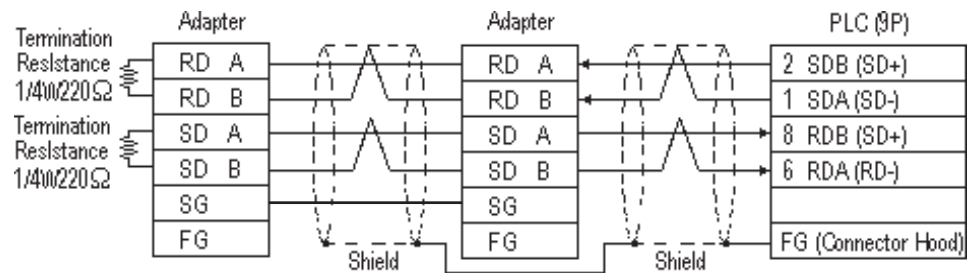

- When using Digital's Multi-link Cable, GP230-IS12-O

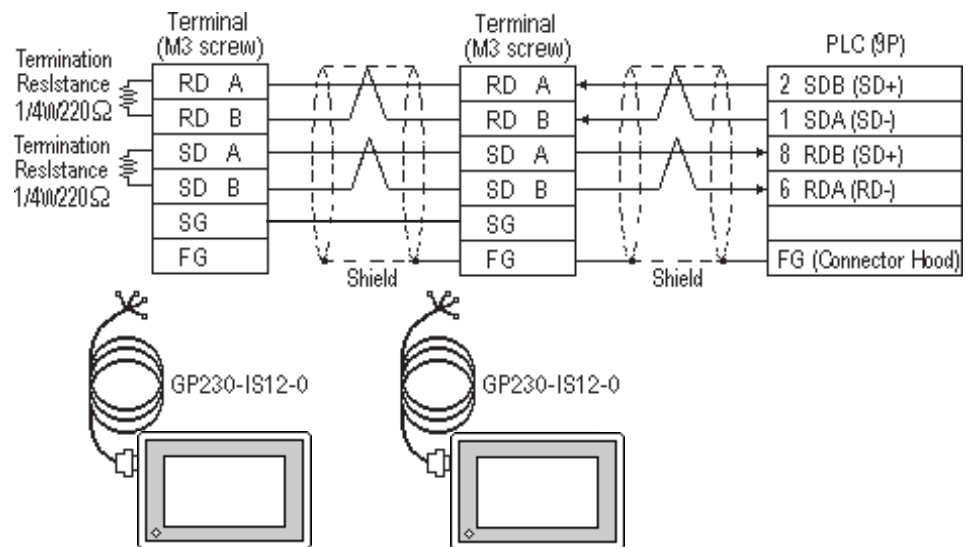

Ground your PLC's FG terminal according to your country's applicable standards. For details, refer to the corresponding PLC manual.



- **Pull out a small amount of the Transfer Cable's shield, make a wire out of it and connect it to the PLC's FG terminal.**
- **The GP230-IS12-O Cable FG terminal is not connected to the GP's FG.**
- **Be aware the A and B signals of the GP and PLC are opposite to each other.**
- **Place a Termination Resistor at both ends of the cable. The Termination Resistor is automatically setup when the PLC's Termination Resistor switch is turned ON.**
- **As a general rule, connect the PLC at one end of the circuit.**

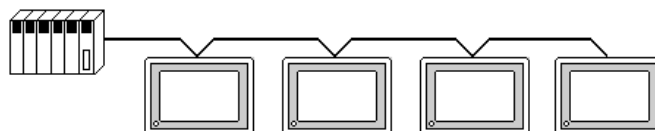



Note: When making your own cable connections, we recommend using HIRAKAWA Densen's H-9293A (CO-HC-ESV-3P*7/0.2).

The cable connection lines are shown below. The cables between the GP and the terminals should be less than 10 meters.

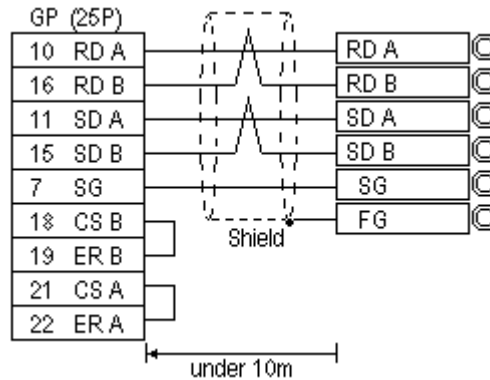

Cable Diagram 4

- When using Digital's RS-422 connector terminal adapter GP070-CN10-O

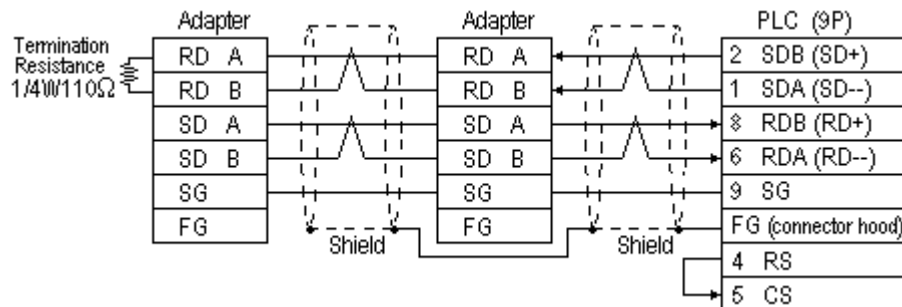

- When using Digital's Multi-link Cable, GP230-IS12-O

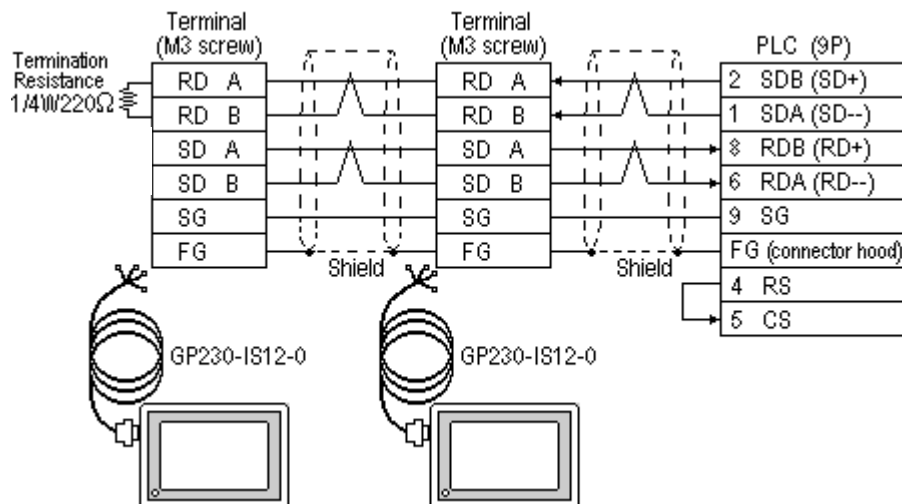



Ground your PLC's FG terminal according to your country's applicable standards. For details, refer to the corresponding PLC manual.



- Pull out a small amount of the Transfer Cable's shield, make a wire out of it and connect it to the PLC's FG terminal.
- Setup the PLC's RS-232C/422 toggle switch as RS-422.
- An Omron connector (XM2A-0901) and connector hood(XM2S-0911) is included with each CV500/CV1000 CPU unit. Other connectors are not compatible.
- The GP230-IS12-O Cable FG terminal is not connected to the GP's FG.
- Be aware the A and B signals of the GP and PLC are opposite to each other.
- Place a Termination Resistor at both ends of the cable. The Termination Resistor is automatically setup when the PLC's Termination Resistor switch is turned ON.
- As a general rule, connect the PLC at one end of the circuit.

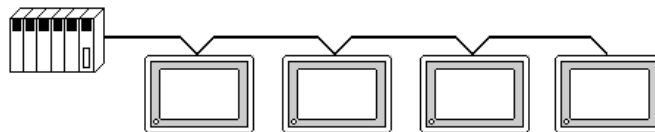

When making your own cable connections, we recommend using Hirakawa Densen's H-9293A (CO-HC-ESV-3P*7/0.2).

The cable connection lines are as illustrated below. The cables between the GP and the terminals should be less than 10 meters.

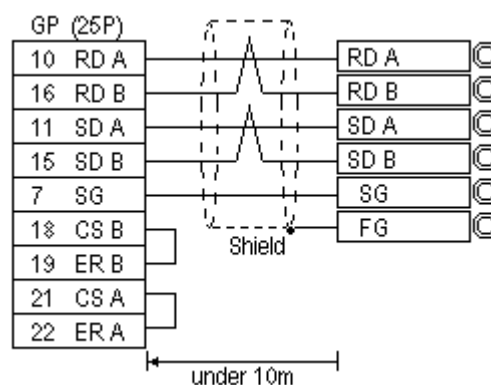

Cable Diagram 5

- When using Digital's RS-422 connector terminal adapter GP070-CN10-O

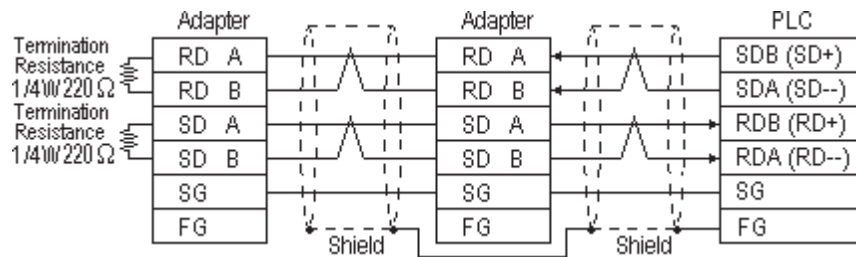

- When using Digital's Multi-link Cable, GP230-IS12-O

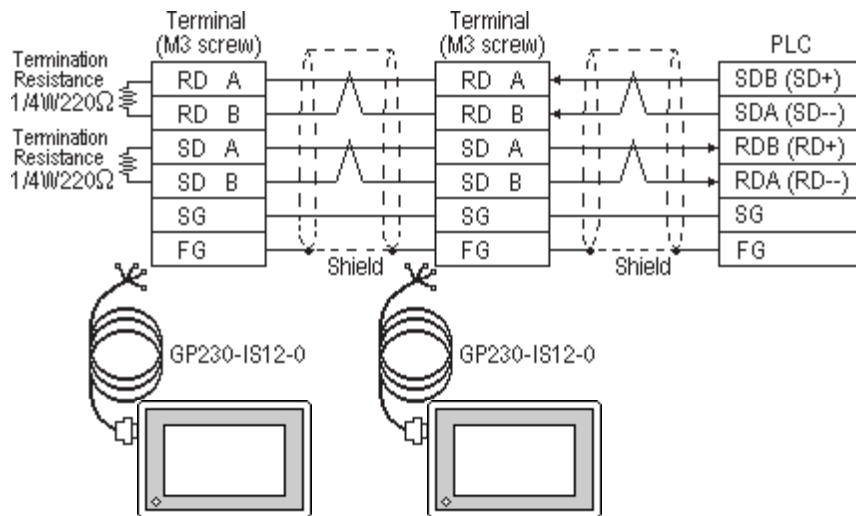

Ground your PLC's FG terminal according to your country's applicable standards. For details, refer to the corresponding PLC manual.



- Pull out a small amount of the Transfer Cable's shield, make a wire out of it and connect it to the PLC's FG terminal.
- Be aware the A and B signals of the GP and PLC are opposite to each other.
- Place a Termination Resistor at both ends of the cable. The Termination Resistor is automatically setup when the PLC's Termination Resistor switch is turned ON.
- As a general rule, connect the PLC at one end of the circuit.

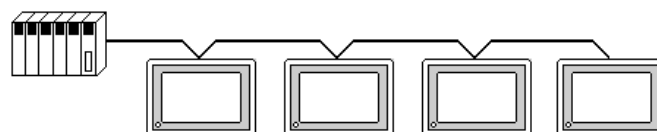



Note: When making your own cable connections, we recommend using Hirakawa Densen's H-9293A (CO-HC-ESV-3P*7/0.2).

The cable connection lines are shown below. The cables between the GP and the terminals should be less than 10 meters.

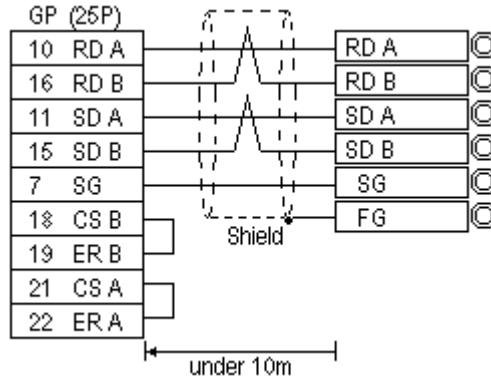

Cable Diagram 6

- When using Digital's RS-422 connector terminal adapter GP070-CN10-0

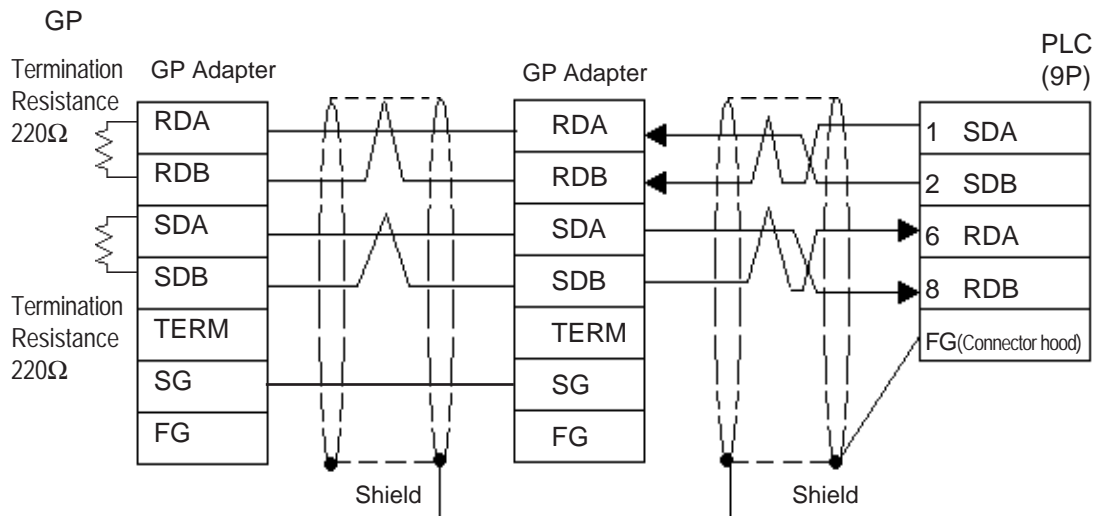

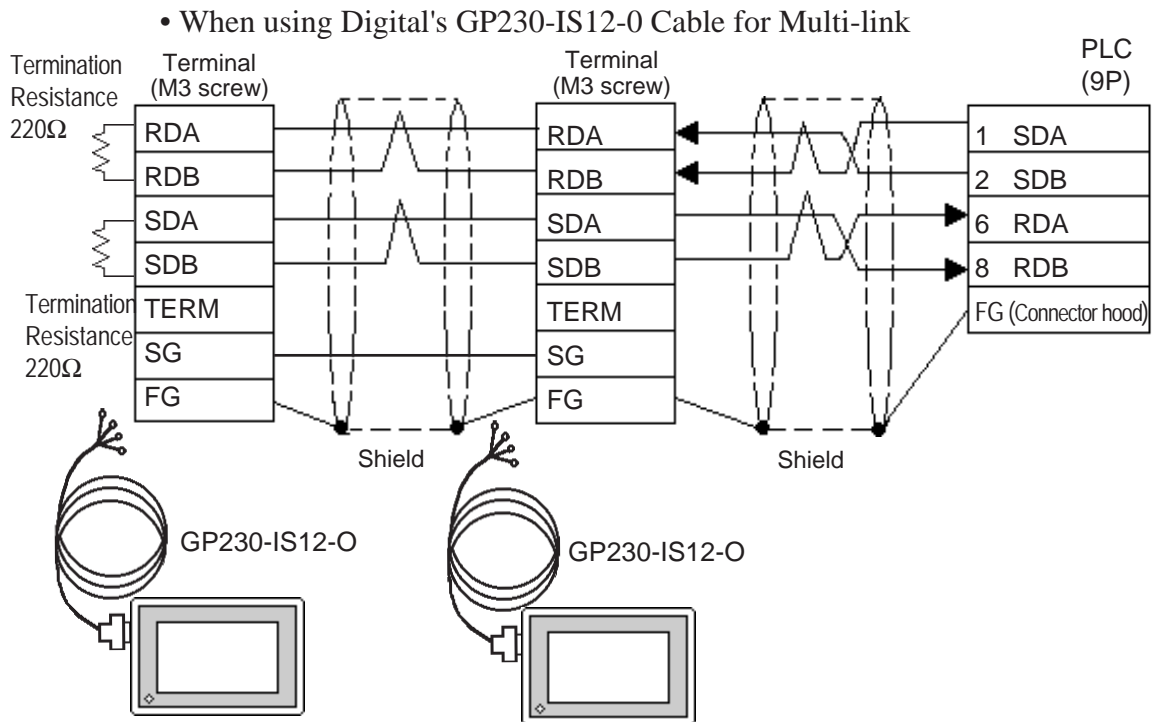

- When making your own cable instead of using GP230-IS12-0

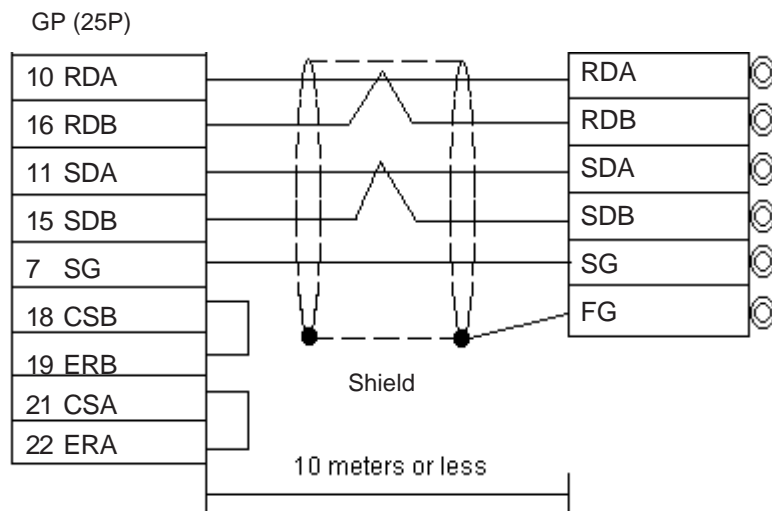

Note:

- Pull out a small amount of the Transfer Cable's shield, make a wire out of it and connect it to the PLC's FG terminal.
- GP230-IS12-0 cable's FG terminal is not connected to GP's FG terminal.
- Be aware the A and B signals of the GP and PLC are opposite to each other.
- Place a Termination Resistor where the GP and PLC are positioned at either end of the cable.
- The PLC's termination resistance will be automatically set when the board's Termination Resistance Switch is turned ON.
- As a general rule, connect the PLC on either end of the circuit.
- RS-422 cables must be 500 meters or less.
- The Hidakawa Hewtech's CO-HC-ESV-3PX7/0.2 cable is recommended for this connection.

5.2.3 Supported Devices

The following describes the range of devices supported by the GP.

■ SYSMAC C Series

 Setup System Area or Communication Information's Storing Address here.

Device	Bit Address	Word Address	Particulars
I/O Relay	00000 ~ 51115	000 ~ 511	L/H
Internal Hold Relay			
Analog Setup Value Storage Area	22000 ~ 22315	220 ~ 223	
Data Link Relay	LR0000 ~ LR6315	LR00 ~ LR63	
Special Hold Relay	24400 ~ 25515	244 ~ 255	
Auxiliary Memory Relay	AR0000 ~ AR2715	AR00 ~ AR27	
Hold Relay	HR0000 ~ HR9915	HR00 ~ HR99	
Timer (contact)	TIM000 ~ TIM511	---	
Counter (contact)	CNT000 ~ CNT511	---	
Timer (current value)	---	TIM000 ~ TIM511	
Counter (current value)	---	CNT000 ~ CNT511	
Data Memory	---	DM0000 ~ DM9999	

* 1 Use the I/O Relay/Internal Hold Relay for setting up this data.



Note:

The procedure for writing bits for T- and W-tags is different for the GP-*30, the GP-*50, and the GP-70 series units:

When performing the bit write operation (other than *Reverse*) using T and W tags on the GP-*30 Series, the corresponding word address, other than the selected bits, is cleared.



Important

- The method of writing bits will differ depending on the GP series.
<GP-*30 series>

When the bit write operation (other than *Reverse*) is performed, the corresponding word address will set the bits to 0 (except the designated bits).

<Except GP-*30 series>

When the bit write operation is performed, the GP reads the PLC's corresponding word address and turns a bit ON, then send back to PLC. Do not write to the word address from the ladder program in the middle of this operation.

- When running a GP-*30 Series ladder program, be aware of the above points.

■ SYSMAC-α Series

 Setup System Area or Communication Information's Storing Address here.

Device	Bit Address	Word Address	Particulars	
I/O Relay I	00000 ~ 02915	000 ~ 029	L/H	
I/O Relay II	30000 ~ 30915	300 ~ 309		
Internal Hold Relay I	03000 ~ 23515	030 ~ 235		
Internal Hold Relay II	31000 ~ 51115	310 ~ 511		
Special Hold Relay I	23600 ~ 25507	236 ~ 255		
Special Hold Relay II	25600 ~ 29915	256 ~ 299		
Hold Relay	HR0000 ~ HR9915	HR00 ~ HR99		
Auxiliary Memory Relay	AR0000 ~ AR2715	AR00 ~ AR27		
Link Relay	LR0000 ~ LR6315	LR00 ~ LR63		
Timer (contact)	TIM000 ~ TIM511	---		
Counter (contact)	CNT000 ~ CNT511	---		
Timer (current value)	---	TIM000 ~ TIM511		
Counter (current value)	---	CNT000 ~ CNT511		
Data Memory	---	DM0000 ~ DM6655		



The procedure for writing bits for T- and W-tags is different for the GP series.

When performing the bit write operation (other than *Reverse*) using T and W tags on the GP-*30 Series, the corresponding word address, other than the selected bits, is cleared.



- The method of writing bits will differ depending on the GP series.

<GP-*30 series>

When the bit write operation (other than *Reverse*) is performed, the corresponding word address will set the bits to 0 (except the designated bits).

<Except GP-*30 series>

When the bit write operation is performed, the GP reads the PLC's corresponding word address and turns a bit ON, then send back to PLC. Do not write to the word address from the ladder program in the middle of this operation.

- When running a GP-*30 Series ladder program, be aware of the above points.

■ SYSMAC CV Series

 Setup System Area or Communication Information's Storing Address here.

Device	Bit Address	Word Address	Particulars	
I/O Relay	00000 ~ 19915	000 ~ 199	L/H	
Internal Hold Relay				
Sysmac BUS/2 Remote I/O Relay	020000 ~ 099915	0200 ~ 0999		
Data Link Relay	100000 ~ 119915	1000 ~ 1199		
Special Hold Relay	A00000 ~ A51115	A000 ~ A511		
Hold Relay	120000 ~ 149915	1200 ~ 1499		
Internal Aux. Relay	190000 ~ 229915	1900 ~ 2299		
SYSBUS Remote I/O Relay	230000 ~ 255515	2300 ~ 2555		
Timer (contact)	T0000 ~ T1023	---		
Counter (contact)	C0000 ~ C1023	---		
Timer (current value)	---	T0000 ~ T1023		
Counter (current value)	---	C0000 ~ C1023		
Data Memory	---	D0000 ~ D9999		



- Write operations cannot be performed on the Timer and Counter bit devices.
- Cannot use the Data Memory extended addresses (E).



- **The procedure for writing bits for T- and W-tags is different for the GP series.**
- **When performing the bit write operation (other than *Reverse*) using T and W tags on the GP-*30 Series, the corresponding word address, other than the selected bits, is cleared.**



- The method of writing bits will differ depending on the GP series.

<GP-*30 series>

When the bit write operation (other than *Reverse*) is performed, the corresponding word address will set the bits to 0 (except the designated bits).

<Except GP-*30 series>

When the bit write operation is performed, the GP reads the PLC's corresponding word address and turns a bit ON, then send back to PLC. Do not write to the word address from the ladder program in the middle of this operation.



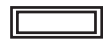

- When running a GP-*30 Series ladder program, be aware of the above points.

■ SYSMAC CS1/CJ /CJ1M Series

In this list, "Exp." means "Expansion".



Setup System Area or Communication Information's Storing Address here.

Device	Bit Address	Word Address	Particulars
Channel I/O	000000 ~ 614315	0000 ~ 6143	
Internal Auxiliary Relay	W00000 ~ W51115	W000 ~ W511	
Hold Relay	H00000 ~ H51115	H000 ~ H511	
Special Auxiliary Relay	A00000 ~ A95915	A000 ~ A959	*1
Timer(Contact)	T0000 ~ T4095	---	*3
Counter(Contact)	C0000 ~ C4095	---	*3
Task Flag (Bit)	TKB00 ~ TKB31	---	*6
Timer(Current)	---	T0000 ~ T4095	
Counter(Current)	---	C0000 ~ C4095	
Data Memory	D0000000 ~ D3276715	D00000 ~ D32767	*2
Exp. Data Memory (E0 ~ EC)	E00000000 ~ EC3276715	E000000 ~ EC32767	*4
Exp. Data Memory (Current Bank)	---	EM00000 ~ EM32767	 *5
Task Flag	---	TK0 ~ TK30	  *3
Index Register	---	IR0 ~ IR15	 *3
Data Register	---	DR0 ~ DR15	 *3

*1 Addresses A000 to A477 cannot be written to.

*2 When using the Communication Unit (CS1W-SCU21/CJ1W-SCU41), addresses D30000 to D31599, since they are used for PLC system settings, should not be written to from the GP.

When using the Communication Board (CS1W-SCB21/41), addresses D32000 to D32767 are used for PLC settings, should not be written to from the GP.

*3 Cannot be written to.

*4 The range of Expansion Data Memory varies depending on the CPU type.

*5 Expansion Data Memory (Current Bank) does not exist on SYSMAC CJ/CJ1M Series.

*6 Data cannot be written.

Reference For details about each device, refer to Omron's SYSMAC CS1 /CJ Series Communication Board CS1W-SCB21-/41 Communication CS1W-SCU21/CJ1W-SCU41 and CJ1W-SCU41 Users Manual.

5.2.4 Environment Setup

The following tables contain Digital's recommended PLC and GP communication settings. The recommended settings are for an RS-232C connection.

■ SYSMAC C Series

GP Setup		Upper Link Unit Setup	
Baud Rate	19200 bps	Baud Rate	19200 bps
Data Length	7 bits	Data Bit	7 bits
Stop Bit	2 bits	Stop Bit	2 bits
Parity Bit	Even	Parity Bit	Even
Data Flow Control	ER Control	---	
Communication Format	4-wire type	Communication Format	RS-422
---		Command Level	Level 1,2,3 is valid
---		Relation	1:N
---		DC +5V power supply	No
---		CTS Setup	Normally On
Unit. No.	0	Station Number	0

■ SYSMAC- α Series

GP Setup		PLC Setup	
Baud Rate	19200 bps	Baud Rate	19200 bps
Data Length	7 bits	Data Bit	7 bits
Stop Bit	2 bits	Stop Bit	2 bits
Parity Bit	Even	Parity Bit	Even
Data Flow Control	ER Control	---	
Communication Format	4-wire type	Change dip SW 1 to indicate either RS-422 or 485 cable (2-wire or 4-wire type)	4
Unit. No.	0	Station Number	0

■ SYSMAC CV Series

GP Setup		PLC Setup	
Baud Rate	19200 bps	Baud Rate	19200 bps
Data Length	7 bits	Data Bit	7 bits
Stop Bit	2 bits	Stop Bit	2 bits
Parity Bit	Even	Parity Bit	Even
Data Flow Control	ER Control	---	
Communication Format	4-wire type	Communication Format	RS-422
Unit. No.	0	Station Number	0

■ SYSMAC CS1/CJ Series

GP Setup		PLC Setup	
Baud Rate	19200	Baud Rate	19200
Data Length	7	Data Length	7
Stop Bit	2	Stop Bit	2
Parity Bit	Even	Parity Bit	Even
Data Flow Control	ER	-	-
Communication Format (using RS422)	4-wire type	WIRE (2-wire/4-wire type Switch)	4-wire type
-	-	TERM (Termination Resistance Switch)	Termination Resistance ON
Unit.No	0	Upper Link Station No.	0
-	-	Serial Communication mode	Upper Link
-	-	Communication Delay Time	0
-	-	CTS Control	None