

Device/PLC Connection Manuals



About the Device/PLC Connection Manuals

Prior to reading these manuals and setting up your device, be sure to read the "Important: Prior to reading the Device/PLC Connection manual" information. Also, be sure to download the "Preface for Trademark Rights, List of Units Supported, How to Read Manuals and Documentation Conventions" PDF file. Furthermore, be sure to keep all manual-related data in a safe, easy-to-find location.

7.5 Omron



When transferring Screen Data:

With this protocol, even if the transfer setting “Do not perform setup” is selected, network information settings will be transferred. As a result, after transferring the same project data to multiple GP units, be sure to check each GP unit’s network information.

7.5.1 System Structure for Ethernet Connection

This section explains the system structures for the Ethernet connection between OMRON PLCs and GP units.

■ SYSMAC CS1 Series

CPU	Link/I/F	Cables	Unit	GP
	 Ethernet Unit			
CS1H-CPU67 CS1H-CPU66 CS1H-CPU65 CS1H-CPU64 CS1H-CPU63 CS1G-CPU45 CS1G-CPU44 CS1G-CPU43 CS1G-CPU42 CS1H-CPU67H CS1H-CPU66H CS1H-CPU65H CS1H-CPU64H CS1H-CPU63H CS1G-CPU45H CS1G-CPU44H CS1G-CPU43H CS1G-CPU42H	CS1W-ETN01	Ethernet cable (compatible with the IEEE802.3)	Pro-face Ethernet I/F Unit GP070-ET11 GP070-ET41 GP377-MLTE11 GP377-MLTE41 GP077-MLTE41	GP Series ^{*1}

**1 Refer to the following page’s table for compatible GP/GLC units and Ethernet connection information.*

Series Name		Product Name	Optional Ethernet I/F Unit	Built-in Ethernet Port
GP77R Series	GP-377R Series	GP-377RT	○ ^{*1 *2}	x
	GP-477R Series	GP-477RE	○ ^{*2}	x
	GP-577R Series	GP-577RS	○ ^{*2}	x
		GP-577RT	○ ^{*2}	x
GP2000 Series	GP-2300 Series	GP-2300L	x	○
		GP-2300S	x	○
		GP-2300T	x	○
	GP-2400 Series	GP-2400T	x	○
	GP-2500 Series	GP-2500L	○ ^{*3 *4}	○
		GP-2500S	○ ^{*3 *4}	○
		GP-2500T	○ ^{*3 *4}	○
	GP-2501 Series	GP-2501L	○ ^{*2 *3}	x
		GP-2501S	○ ^{*2 *3}	x
		GP-2501T	○ ^{*2 *3}	x
	GP-2600 Series	GP-2600T	○ ^{*3 *4}	○
	GP-2601 Series	GP-2601T	○ ^{*2 *3}	x
GLC2000 Series	GLC-2300 Series	GLC-2300L	x	○
		GLC-2300T	x	○
	GLC-2400 Series	GLC-2400T	x	○
	GLC-2500 Series	GLC-2500T	○ ^{*3 *4}	○
	GLC-2600 Series	GLC-2600T	○ ^{*3 *4}	○
ST Series	ST403	x	○	

*1 Only Multi unit can be used.

*2 The 2-Way Driver (Pro-Server, GP-Web and others) cannot be used.



*3 When using optional Ethernet I/F unit, a bus conversion unit (PSL-CONV00) is required.

*4 Using the optional Ethernet I/F Unit allows you to set up separate Class and Net No.s for 2-Way Driver applications (Pro-Server, GP-Web and others) and the PLC. When doing this, data transfer with the PLC is performed through the optional Ethernet I/F Unit.

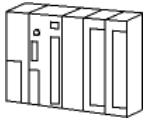

- For cable connections, refer to the user's manual for each optional unit. For the GP2000 and GLC2000 series units, however, refer to the user's manual for the main unit.

■ SYSMAC CJ Series

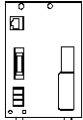
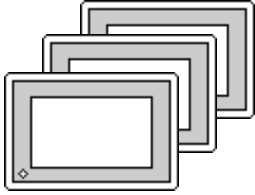
CPU	Link/I/F	Applicable Cable	Unit	GP/GLC
	 Ethernet Unit			
CJ1G-CPU44 CJ1G-CPU45 CJ1G-CPU42H CJ1G-CPU43H CJ1G-CPU44H CJ1G-CPU45H	CJ1W-ETN11 CJ1W-ETN21	Ethernet Cable Equivalent to IEEE802.3	Digital's GP070-ET11 GP070-ET41 GP377-MLTE11 GP377-MLTE41 GP077-MLTE41	GP/GLC Series *1

*1 Refer to the following table for compatible GP/GLC units and Ethernet connection information.

Series Name		Product Name	Optional Ethernet I/F Unit	Built-in Ethernet Port	
GP77R Series	GP-377R Series	GP-377RT	○ ^{*1*2}	x	
	GP-477R Series	GP-477RE	○ ^{*2}	x	
	GP-577R Series	GP-577RS	○ ^{*2}	x	
		GP-577RT	○ ^{*2}	x	
GP2000 Series	GP-2300 Series	GP-2300L	x	○	
		GP-2300S	x	○	
		GP-2300T	x	○	
	GP-2400 Series	GP-2400T	x	○	
		GP-2500 Series	GP-2500L	○ ^{*3*4}	○
			GP-2500S	○ ^{*3*4}	○
	GP-2500T		○ ^{*3*4}	○	
	GP-2501 Series	GP-2501L	○ ^{*2*3}	x	
		GP-2501S	○ ^{*2*3}	x	
		GP-2501T	○ ^{*2*3}	x	
GP-2600 Series	GP-2600T	○ ^{*3*4}	○		
	GP-2601 Series	GP-2601T	○ ^{*2*3}	x	
GLC2000 Series	GLC-2300 Series	GLC-2300L	x	○	
		GLC-2300T	x	○	
	GLC-2400 Series	GLC-2400T	x	○	
	GLC-2500 Series	GLC-2500T	○ ^{*3*4}	○	
	GLC-2600 Series	GLC-2600T	○ ^{*3*4}	○	
ST Series		ST403	x	○	

*1 Only Multi unit can be used.

*2 The 2-Way Driver (Pro-Server, GP-Web and others) cannot be used.



*3 When using optional Ethernet I/F unit, a bus conversion unit (PSL-CONV00) is required.

*4 Using the optional Ethernet I/F Unit allows you to set up separate Class and Net No.s for 2-Way Driver applications (Pro-Server, GP-Web and others) and the PLC. When doing this, data transfer with the PLC is performed through the optional Ethernet I/F Unit.

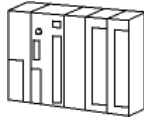

• For cable connections, refer to the user's manual for each optional unit. For the GP2000 and GLC2000 series units, however, refer to the user's manual for the main unit.

■SYSMAC CJ1M Series

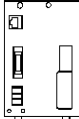
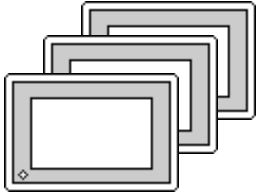
CPU	Link/I/F	Applicable Cable	Unit	GP/GLC
	 Ethernet Unit			
CJ1M-CPU12 CJ1M-CPU13 CJ1M-CPU22 CJ1M-CPU23	CJ1W-ETN11	Ethernet Cable Equivalent to IEEE802.3	Digital's GP070-ET11 GP070-ET41 GP377-MLTE11 GP377-MLTE41 GP077-MLTE41	GP/GLC Series ^{*1}

**1 Refer to the following table for compatible GP/GLC units and Ethernet connection information.*

Series Name		Product Name	Optional Ethernet I/F Unit	Built-in Ethernet Port
GP77R Series	GP-377R Series	GP-377RT	○ ^{*1*2}	x
	GP-477R Series	GP-477RE	○ ^{*2}	x
	GP-577R Series	GP-577RS	○ ^{*2}	x
		GP-577RT	○ ^{*2}	x
GP2000 Series	GP-2300 Series	GP-2300L	x	○
		GP-2300S	x	○
		GP-2300T	x	○
	GP-2400 Series	GP-2400T	x	○
	GP-2500 Series	GP-2500L	○ ^{*3*4}	○
		GP-2500S	○ ^{*3*4}	○
		GP-2500T	○ ^{*3*4}	○
	GP-2501 Series	GP-2501L	○ ^{*2*3}	x
		GP-2501S	○ ^{*2*3}	x
		GP-2501T	○ ^{*2*3}	x
	GP-2600 Series	GP-2600T	○ ^{*3*4}	○
GP-2601 Series	GP-2601T	○ ^{*2*3}	x	
GLC2000 Series	GLC-2300 Series	GLC-2300L	x	○
		GLC-2300T	x	○
	GLC-2400 Series	GLC-2400T	x	○
	GLC-2500 Series	GLC-2500T	○ ^{*3*4}	○
	GLC-2600 Series	GLC-2600T	○ ^{*3*4}	○
ST Series		ST403	x	○

**1 Only Multi unit can be used.*

**2 The 2-Way Driver (Pro-Server, GP-Web and others) cannot be used.*

**3 When using optional Ethernet I/F unit, a bus conversion unit (PSL-CONV00) is required.*

**4 Using the optional Ethernet I/F Unit allows you to set up separate Class and Net No.s for 2-Way Driver applications (Pro-Server, GP-Web and others) and the PLC. When doing this, data transfer with the PLC is performed through the optional Ethernet I/F Unit.*



Note:

- For cable connections, refer to the user's manual for each optional unit. For the GP2000 and GLC2000 series units, however, refer to the user's manual for the main unit.

◆ Connection Structure

< 1 : n connection >

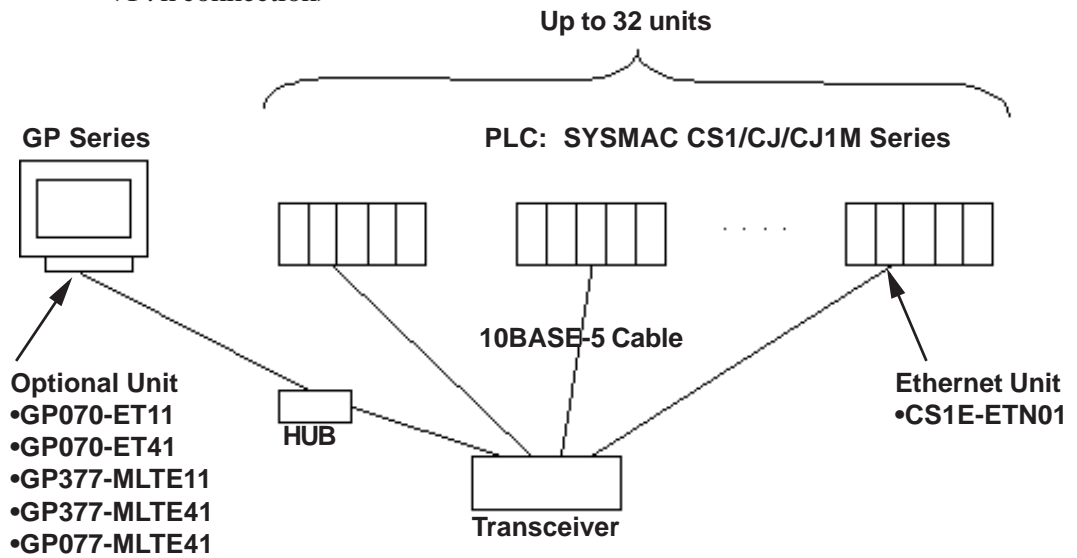

<n:1 connection >

n units (While there is no limitation to the number of units connected, as the number increases, the communication load will also increase, which can lead to slower communication.)

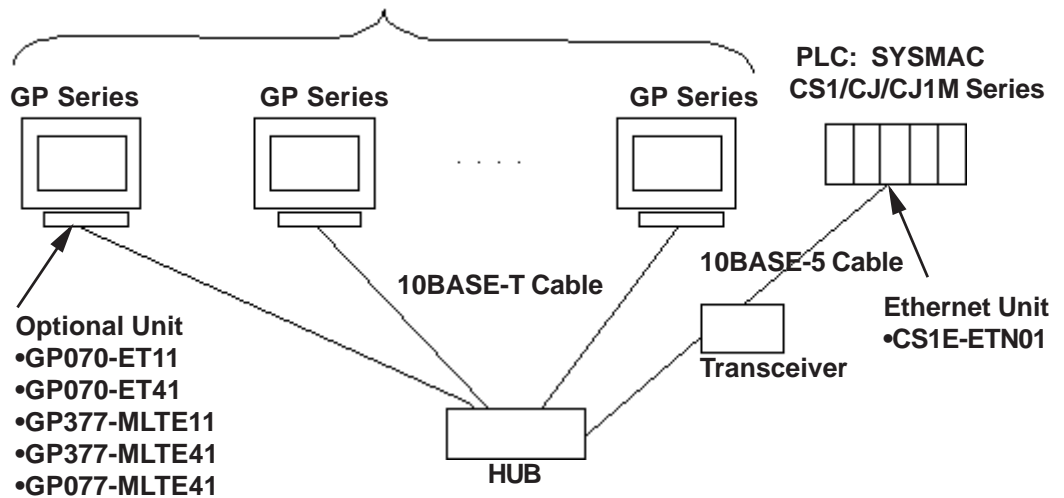

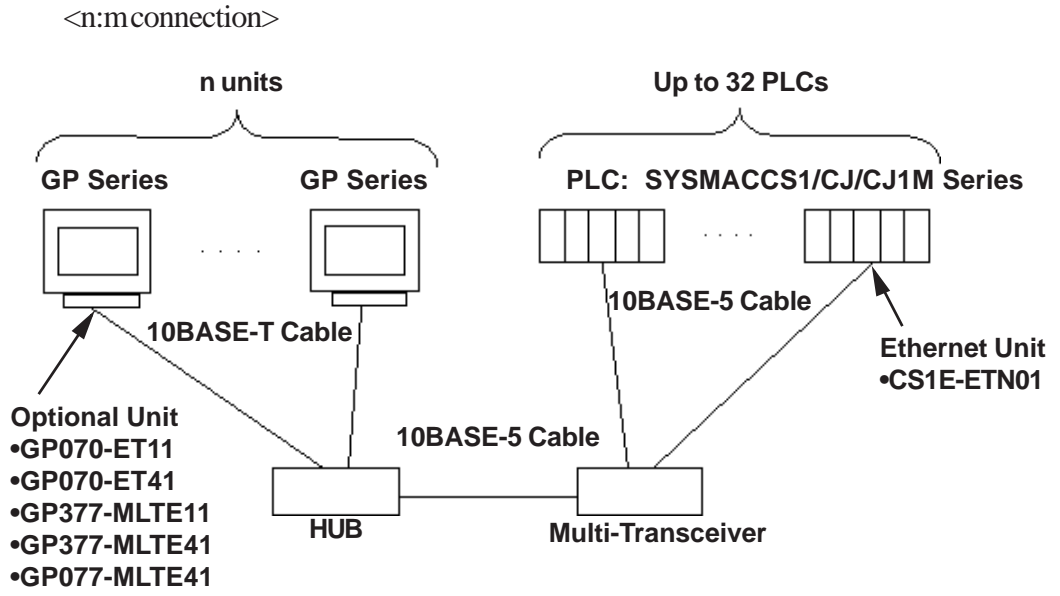

◆ Network Design

- When the GP and the target PLC use the same network address.

GP Settings

IP Address : 192.168.0.1
 FINS UDP Port No. : 9600
 Network Address : 1
 Node Address : 50

PLC Settings

IP Address : 192.168.0.2
 FINS UDP Port No. : 9600
 Network Address : 1
 Node Address : 100

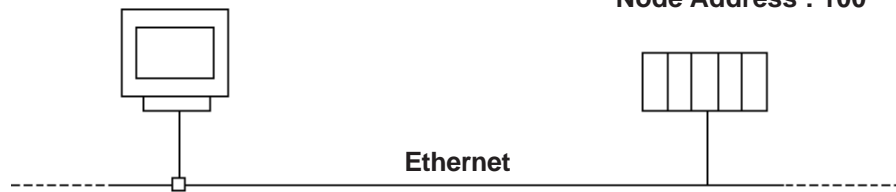

GP to PLC Setting Information

Destination Node IP Address : 192.168.0.2
 FINS UDP Port No. : 9600 (Default)
 Network Address : 1
 Node Address : 100

- When there is a junction PLC used between the GP and target PLC.

GP Settings

IP Address : 192.168.0.1
 FINS UDP Port No. : 9600
 Network Address : 1
 Node Address : 50

Junction PLC Settings

IP Address : 192.168.0.2
 FINS UDP Port No. : 9600

PLC Settings

Network Address : 2
 Node Address : 1

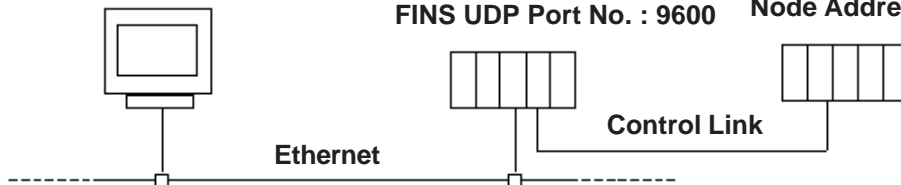

GP to PLC Setting Information

Destination IP Address : 192.168.0.2 (IP Address for Junction PLC)
 FINS UDP Port No. : 9600 (Default) (Port No. for Junction PLC)
 Destination Network Address : 2
 Destination Node Address : 1

7.5.2 Supported Devices

The following list shows the range of devices supported by the GP.

■ SYSMAC CS1/CJ/CJ1M Series

Setup System Area here.

Device	Bit Address	Word Address	Other		
Channel I/O	CIO000000 ~ CIO614315	CIO0000 ~ CIO6143		*2	L/H
Internal Auxiliary Relay	W00000 ~ W51115	W000 ~ W511			
Hold Relay	H00000 ~ H51115	H000 ~ H511			
Special Auxiliary Relay	A00000 ~ A95915	A000 ~ A959		*1	
Timer (Contact)	T0000 ~ T4095	_____		*3	
Counter (Contact)	C0000 ~ C4095	_____		*3	
Task Flag (Bit)	TKB00 ~ TKB31	_____		*6	
Timer (Current)	_____	T0000 ~ T4095			
Counter (Current)	_____	C0000 ~ C4095			
Data Memory	D0000000 ~ D3276715	D00000 ~ D32767		*2	
Expansion Data Memory (E0 ~ EC)	E00000000 ~ EC3276715	E000000 ~ EC32767		*4	
Expansion Data Memory (Current Bank)	_____	EM00000 ~ EM32767	Bit 5	*5	
Task Flag	_____	TK0 ~ TK30	÷2 Bit 5	*3	
Index Register	_____	IR0 ~ IR15	Bit 3	*3	
Data Register	_____	DR0 ~ DR15	Bit 5	*3	

*1 A00 through A477 are not available for writes.

*2 When the Ethernet unit (CS1W-ETN01) is used, the data memory addresses D30000 through D31599 and the channel I/O addresses C101500 through C101899 are used as the system setup area by the PLC. Therefore, do not write data to these addresses from the GP.

Reference For further details, refer to the user's manual for OMRON's SYSMAC CS Series Ethernet Unit, CS1W-ETN01J SYSMAC CJ Series Ethernet Unit User Manual.

*3 Data cannot be written in RUN mode.

*4 The range of the extended data memory (E0 to EC) varies depending upon the CPU models. This device is not available with CJ1M series CPUs.

*5 Extended data memory (current bank) is not available with CJ/CJ1M series CPUs.

*6 Cannot be written to.

■ CS1 Ethernet Protocol Limitation

Even though the CS1 Ethernet Protocol can access more than one CPU, the following limitations apply.

◆ Device Address and Node Number Limitations

When a device address's size is larger than 1024 (1K) or a different network and node addresses are set, the number of available device addresses will vary. The GP uses internal records that are used to set the device addresses. These records are limited to 64. For example, when the D0 device address is set, a single record is used in the GP. For detailed examples, refer to the following chart.

Ex1.) Number of records used when designating tag setting numbers.

Setting No.	Network Address	Node Address	Device Address	Remaining Number of records in GP-PRO/PBIII	Other
1	1	1	D0	63	Uses one record
2	1	1	D1024	62	Uses one record
3	2	1	D0	61	Uses one record
4	2	1	D1024	60	Uses one record
5	2	1	T0	60	Since the node number and address range already exist as setting No.3, no records will be used.
6	2	1	T1024	60	Since the node number and address range already exist as setting No.4, no records will be used.
7	2	1	D2048	59	Uses one record
8	2	2	D2048	58	Uses one record
9	3	1	D2048	57	Uses one record
10	3	1	D2049	57	Since the node number and address range already exist as setting No.9, no records will be used.

When the total number of Network Addresses, Node Addresses and Device Addresses exceeds 1024, GP internal records are used. However, if the Network Address, Node Address and Device Address are the same type, no record will be used, even if the device types are different.

Ex2.) When setting tags from D00000 to D16384 in Data Memory, since one record is used for every 1024 addresses, a total of 16 records will be used.

$$16384/1024=16$$

Therefore, when setting the same number of tags for each node, settings for only a total of only four nodes can be set.

$$64/16=4$$



Note: When the number of records is over 65, the following error message will appear on the GP Screen Editor software (GP-PRO/PBIII for Windows).

“Address entry limit reached. No more can be entried”

◆ PLC Device Block Write and Read Out Restrictions

The GP unit processes data internally by separating data into blocks of 1024 words. Therefore, when a Block Write is requested that uses 41 or more words and will exceed the 1024 word limit,

the following features cannot be used.

- PLC Device Write using D-Script's Memory Operation Feature
- Write from GP/GLC SRAM to PLC Device using Filing Feature
- Write to LS Area's Read Area
- Tag, D-Script Offset Value setting.

For the following feature, a Block Read Out that will exceed the 1024 word limit cannot be used.

When designating consecutive addresses on a screen with D-Script or Tags, set them within the 1024 word limit.

- Tag, D-Script Offset Value setting

- Ex.)-
- When 400 words from D1000 are designated for a Block Display of Trend Graph
 - When 100 words from E2000 are designated for a Memory Copy of D-Script

If the above problem occurs, separate the data so that the number of words used by the Block Write is 1024 or less.



A Host Communication Error (02:**:**:**)** message may be displayed if the above usage restrictions are not followed. (The error code indicated by ** varies depending on the operating conditions.)

◆ **When setting parts or tags from GP Screen Editor (GP-PRO/PBIII for Windows)**

Before setting parts or tags, Network Information settings must be entered. Network Information Setting can be set from the [GP SYSTEM SETTING]->[MODE SETTIN]->[Network Information] screen.

Reference this manual, 7.5.3 Environment Setup

Specifying the PLC's Network Address and Node Address when setting parts or tags, allows the specified PLC's Device to be read out.

Setting Example

When the Destination Network Address is 1 and Node Address is 1, "1" for the Network Address and "1" for the Node Address.

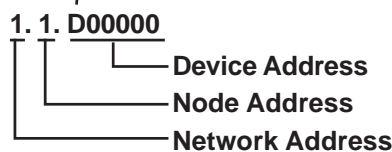
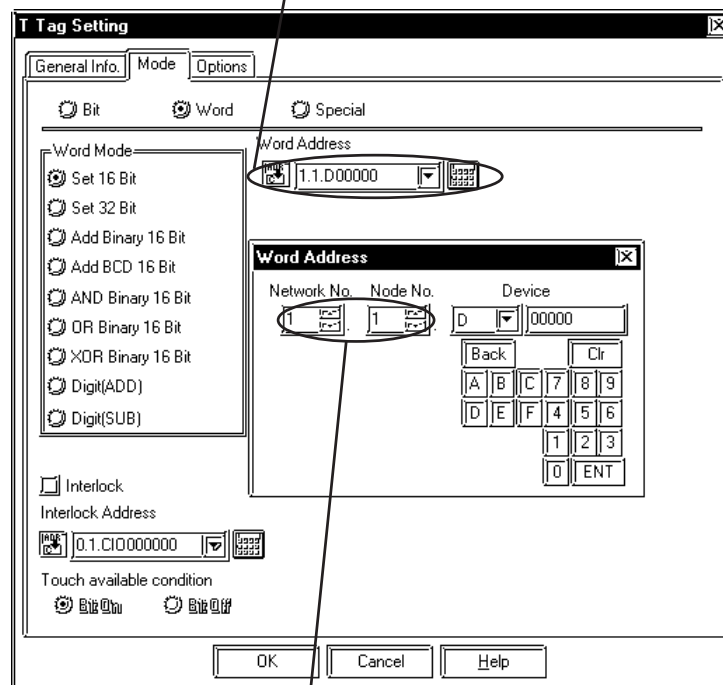

Note: In case of setting parts or tags from GP Screen Editor (GP-PRO/PBIII for Windows), PLC's Network Address and Node Address can be set when inputting the address. When the Network Address or Node Address are not specified, the previously entered numbers are kept. When entering new setup values, the default values are:

Network Address : 0

Node Address : 1

7.5.3 Environment Setup

■ GP Settings

The following screens show the GP's communication settings, which are required for communications via the Ethernet connection:

◆ SET UP OPERATION SURROUNDINGS MENU

<GP-477R Series, GP-577R Series, GP2000 Series>

SETUP OPERATION SURROUNDINGS MENU		RETURN
1	SETUP OPERATION SURROUNDINGS	
2	SETUP ETHERNET INFORMATION	
3	SETUP ETHERNET EXT. INFORMATION	
4	DESTINATION NODE INFORMATION	

<GP-377R Series>

MAIN	INITIALIZE	PLC SETTING
SETUP OPERATION SURROUNDINGS1		
SETUP OPERATION SURROUNDINGS2		
SETUP ETHERNET INFORMATION		
SETUP ETHERNET EXT. INFORMATION		
DESTINATION NODE INFORMATION		

• **SET UP OPERATION SURROUNDINGS**

<GP-477R Series, GP-577R Series, GP2000 Series>

SETUP OPERATION SURROUNDINGS		SET	CANCEL
STARTING ADDRESS OF SYSTEM DATA AREA	[D]		
DESTINATION NETWORK ADDRESS	[]		
DESTINATION NODE ADDRESS	[]		
SYSTEM AREA READING AREA SIZE (0-256)	[]		
RESET GP ON DATA WRITE ERROR	ON OFF		
<p>Note! The system start address, network address and node address cannot be change on GP. Please use GP-PRO/PB3 to set this data and re-send to the GP.</p>			
1	2	3	4
5	6	7	8
9	0	↑	↓
		←	→
			BS

<GP-377R Series>

SETUP OPERATION SURROUNDINGS1		SET	ESC
SYSTEM AREA START ADR D	<input type="text"/>		
DEST NETWORK ADR	<input type="text"/>		
DEST NODE ADR	<input type="text"/>		
Please use GP-PRO/PB3 to modify the address for system, network and node.			
SETUP OPERATION SURROUNDINGS2		SET	ESC
SYSTEM AREA READ SIZE	<input type="text"/>		
RESET GP ON WRITE ERROR	<input type="text"/>		



Be sure the Destination Network Address and Destination Node Address entered are the same as the PLC's settings. However, the Destination Network Address and Destination Node Address settings cannot be changed from the GP's OFFLINE mode. Be sure to make these settings from the GP Screen Editor's [GP SYSTEM SETUP] -> [MODE SETUP] setting area..

Reference This manual, 7.5.3 Environment Setup ■GP Screen Editor software (GP-PRO/PBIII for Windows) Settings

◆ SETUP ETHERNET INFORMATION

Enter each item in the SET UP ETHERNET INFORMATION screen.

<GP-477R Series, GP-577R Series, GP2000 Series>

SETUP ETHERNET INFORMATION												SET	CANCEL	
SRC IP ADDRESS	[]	.	[]	.	[]	.	[]			
SRC NETWORK ADDRESS	[]												
SRC NODE ADDRESS	[]												
FINS UDP PORT NO.	[]												
	1	2	3	4	5	6	7	8	9	0		↑	↓	BS
												←	→	

<GP-377R Series>

SETUP NETWORK INFORMATION												SET	ESC
SRC IP ADD.	[]	.	[]	.	[]	.	[]		
SRC NETWORK ADDRESS													
SRC NODE ADDRESS													
FINS UDP PORT NO.													

• SRC IP ADDRESS

Enter the IP address for the GP at your satation. To do this, separate the 32 bits of the IP address into four segments of eight bits each, delimit those segments with a dot, and then enter them as decimal numbers.

• SRC NETWORK ADDRESS (0 to 127)

Enter your GP's Network address.

• SRC NODE ADDRESS (0 to 126)

Enter your GP's Node address.

• FINS UDP PORT NO. (1024 to 65535)

Enter the FINS UDP port number, between 1024 and 65535. Set the port number so that it is the same as the PLC's FINS UDP port number. The PLC's default value is 9600. When connecting one PLC with more than one GP unit, all GP FINS UDP port numbers need to be set as the same values.



Do not specify duplicate IP addresses. Contact your network manager about assigning IP addresses.



- When using the built-in Ethernet port on a GP2000 Series unit, be sure not to enter duplicate "SRC PORT No." values.

Check the 2-way driver's "SRC PORT No." Setting via the following menu:

GP OFFLINE mode's Main menu [INITIALIZE] -> [SETUP OPERATION SURROUNDINGS] -> [EXTENDED SETTINGS] -> [SETUP ETHERNET INFORMATION] screen.

The default value is 8000. The 2-way driver uses this port and the following nine ports for a total of 10 (8000 ~ 8009).

◆ SET UP NETWORK EXT. INFORMATION

<GP-477R Series, GP-577R Series, GP2000 Series>

SETUP ETHERNET EXT. INFORMATION		SET	CANCEL
SEND WAIT TIME	[] (ms)		
TIMEOUT	[] (x 2sec)		
IP ROUTER ADDRESS	[] . [] . [] . []		
SUBNET MASK	[] . [] . [] . []		
UDP RETRY COUNT(0-255)	[]		

	1	2	3	4	5	6	7	8	9	0			↑	↓	BS
													←	→	

<GP-377R Series>

SETUP NETWORK EXT. INFORMATION		SET	ESC
SEND WAIT TIME	[] (ms)		
TIMEOUT	[] (x 2sec)		
IP ROUTER ADD.	[] . [] . [] . []		
SUBNET MASK	[] . [] . [] . []		
UDP RETRY COUNT(0-255)	[]		

- **SEND WAIT TIME (0 to 255)**

Wait time can be added when a command is transmitted from the GP. Use the wait time if the traffic on the communications line is heavy. If no wait time is required, enter “0.”

- **TIMEOUT (0 to 65535)**

Enter the desired timeout value. If no response is received from the other station within the specified time, a timeout occurs. If “0” is specified, the default time is 5 seconds with UDP/IP communication.

- **IP ROUTER ADDRESS**

Enter the IP address of the router (only one). If no router is used, enter “0” in all fields.

- **SUBNET MASK**

Enter the subnet mask settings. If no subnet mask is used, enter “0” in all fields.

- **UDP RETRY COUNT (0 to 255)**

Designates the number of times the GP re-sends a command when there is no reply from the other port and a timeout occurs. When no reply is received after the retry setting number is reached, an error message will appear on the GP screen.



- ***If GP memory is initialized in OFFLINE mode, random values may be included. Download the GP System Setting from GP-PRO/PBIII for Windows.***

• DESTINATION NODE INFORMATION

<GP-477R Series, GP-577R Series, GP2000 Series>

DESTINATION NODE INFORMATION		
		PREVIOUS
		NEXT
		END
NETWORK	NODE	IP ADDRESS
1	1	192.168.0.1
1	2	192.168.0.2
1	3	192.168.0.3
1	4	192.168.0.4
Please use GP-PRO/PB3 to change them settings.		

<GP-377R Series>

DESTINATION NODE INFO		
		PRE
		NEXT
		ESC
NETWORK	NODE	IP ADDRESS
1	1	192.168.0.1
1	2	192.168.0.2
1	3	192.168.0.3
1	4	192.168.0.4
Please use GP-PRO/PB3 to change them.		

• DESTINATION NODE INFORMATION

The Destination (PLC) Network Address, Destination Node Address and IP Address are displayed here. Press [NEXT] button to see the next page.



The DESTINATION NODE INFORMATION cannot be set or changed from the OFFLINE mode. Set or change these values from the GP Screen Editor software (GP-PRO/PBIII for Windows) [GP SYSTEM SETTINGS]-> [MODE SETTINGS] -> [NETWORK INFORMATION SETTINGS].

Reference

This manual, 7.5.3 Environment Setup ■GP Screen Editor software (GP-PRO/PBIII for Windows) Settings

■ GP Screen Editor software (GP-PRO/PBIII for Windows) settings

The following items can be entered from the GP Screen Editor software (GP-PRO/PBIII for Windows) [GP SYSTEM SETTINGS] -> [MODE SETTING] area.

Menu	Sub Menu	Item
Communication Settings	_____	SRC IP ADDRESS
		FINS UDP PORT NO.
	Advanced Communication Settings	SEND WAIT TIME
		TIME OUT
		IP ROUTER ADDRESS
	SUBNET MASK	
Mode Settings	_____	SYSTEM START ADDRESS
		READ AREA SIZE
	Network Information Settings	NETWORK ADDRESS
		NODE ADDRESS
		DESTINATION NETWORK ADDRESS
		DESTINATION NODE ADDRESS
	DESTINATION IP ADDRESS	

◆ COMMUNICATION SETTINGS

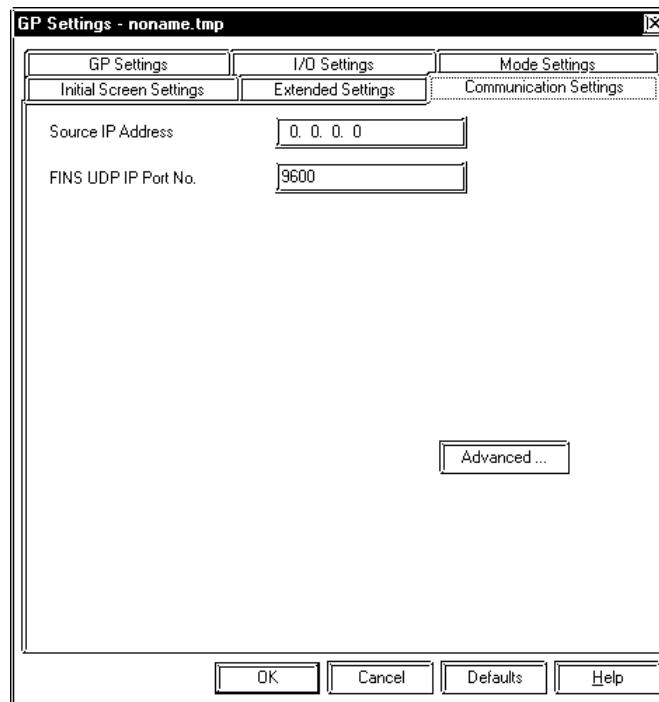

• SRC IP ADDRESS

Enter the IP address for the GP at your saturation. To do this, separate the 32 bits of the IP address into four segments of eight bits each, delimit those segments with a dot, and then enter them as decimal numbers.

• FINS UDP PORT NO. (1024 ~ 65535)

Enter the FINS UDP port number, between 1024 and 65535. Set the port number so that it is the same as the PLC's FINS UDP port number. The PLC's default value is 9600. When connecting one PLC with more than one GP unit, all GP FINS UDP port numbers need to be set as the same values.

•ADVANCED COMMUNICATION SETTINGS

The screenshot shows a dialog box titled "Advanced Communication Setup". It contains the following fields and values:

- Send Wait Time: 0 msec
- Time Out: 0 x2 sec
- IP Router Address: 0. 0. 0. 0
- Subnet Mask: 0. 0. 0. 0
- UDP Retry Count: 2

Buttons on the right: OK, Cancel, Help.

• SEND WAIT TIME (0 to 255)

Wait time can be added when a command is transmitted from the GP. Use the wait time if the traffic on the communications line is heavy. If no wait time is required, enter "0."

• TIMEOUT (0 to 65535)

Enter the desired timeout value. If no response is received from the other station within the specified time, a timeout occurs. If "0" is specified, the default time is 5 seconds with UDP/IP communication.

• IP ROUTER ADDRESS

Enter the IP address of the router (only one). If no router is used, enter "0" in all fields.

• SUBNET MASK

Enter the subnet mask settings. If no subnet mask is used, enter "0" in all fields.

• UDP RETRY COUNT (0 to 255)

Designates the number of times the GP re-sends a command when there is no reply from the other port and a timeout occurs. When no reply is received after the retry setting number is reached, an error message will appear on the GP screen.

◆MODE SETTINGS

•SYSTEM START ADDRESS SETTINGS

System Start Address Settings are as shown below. The System Area and Read Area are assigned to the PLC node designated here.

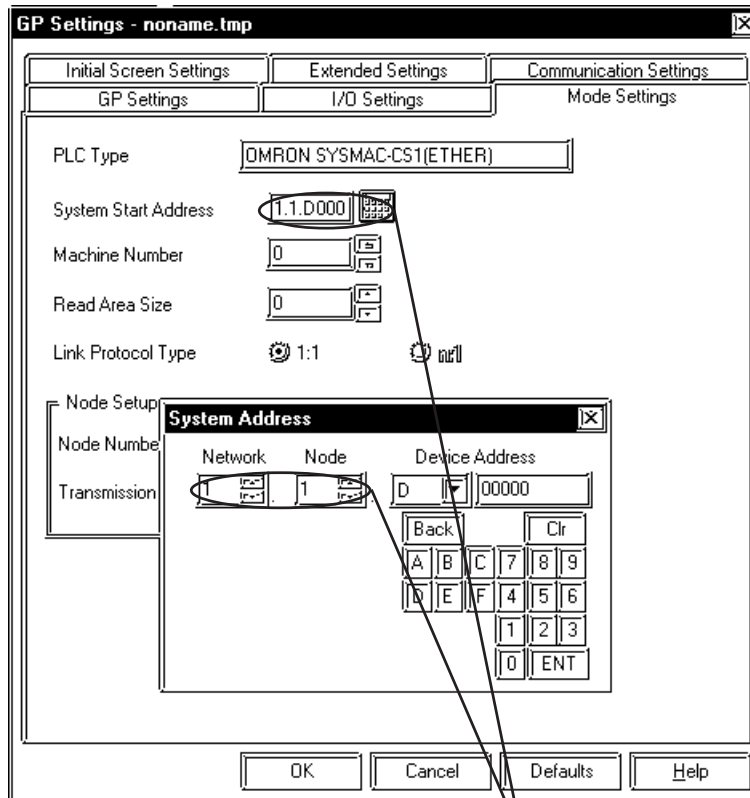

The System Start Address is allocated to the PLC node entered here. Set the Network Address and Node Address to the same address values as set in the Destination Node Information. (Set in the [MODE SETTINGS] -> [NETWORK SETTINGS].).

•NETWORK INFORMATION SETTINGS

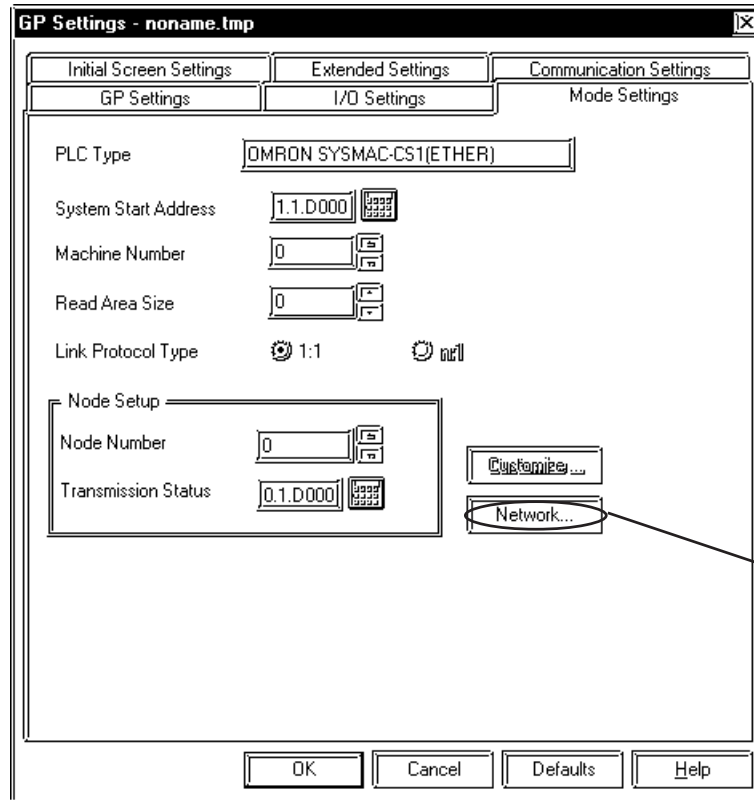

Click on this button to set the Network Information.

The Source Node Info and Destination Node Info are set as shown below.

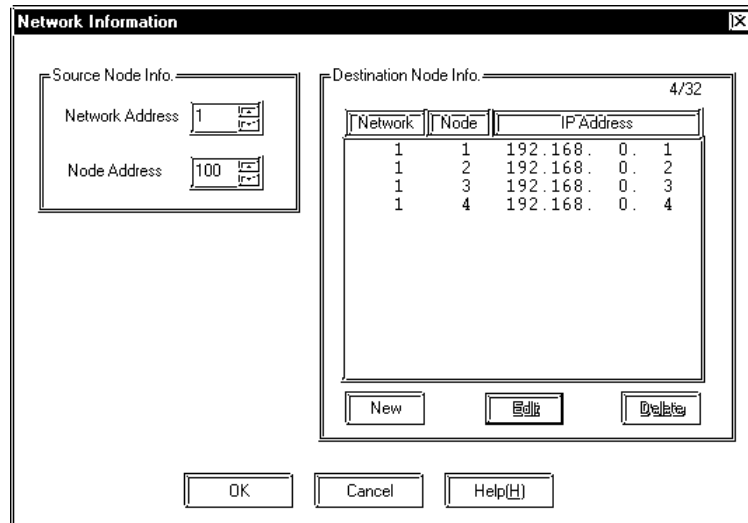

The Source Node Info can be entered by clicking on that item directly.

• SOURCE NODE INFO.

Enter your GP's Network Address and Node Address.

When entering Destination Node Information Settings, click on New or Edit button and the dialog box shown below appears.

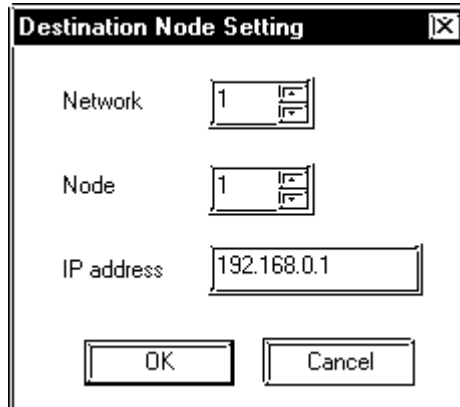

The image shows a dialog box titled "Destination Node Setting" with a close button (X) in the top right corner. It contains three input fields: "Network" with the value "1", "Node" with the value "1", and "IP address" with the value "192.168.0.1". At the bottom, there are two buttons: "OK" and "Cancel".

- **DESTINATION NODE SETTING**

Enter the destination PLC Node number. The Maximum number of Nodes is 32. The Destination PLC Node IP Address needs to be set to the same address as the target PLC or the junction PLC's IP address. The Destination Network Address and Destination Node Address need to be set to the target PLC's addresses.

■ **PLC SETTINGS**

◆ **SYSMAC CS1 /CJ/CJ1M Series**

Item	GP Settings		PLC Settings	
SRC IP Address	SRC IP Address	GP's Address *1	IP Address Setting Switch	PLC's Address
SRC Node Address	SRC Node Address	GP's Address	Node No. Switch	PLC's No.
SRC Network Address	SRC Network Address	GP's Address	Network Address	PLC's Address
Destination IP Address	Destination IP Address	Target or transit PLC's IP Address	IP Address Table	GP's IP Address
Destination Node Address	Destination Node Address	Target or transit PLC's Node Address	IP Address Table	GP's Node Address
Destination Network Address	Destination Network Address	Target or transit PLC's Network Address	_____	_____
Port No. *2	FINS UDP Port No.	9600	FINS UDP Port No.	9600

*1 Contact your network administrator about setting values.

*2 PLC's default Port number is 9600. Be sure to set the same number as the GP setting.

When using the following function on a GP2000 Series unit, be sure not to use duplicate port number values. Check the 2-way driver's port number setting via the following menu:

GP OFFLINE mode's Main menu [INITIALIZE] -> [SETUP OPERATION SURROUNDINGS] -> [EXTENDED SETTINGS] -> [SETUP ETHERNET INFORMATION].

The default value is 8000. The 2-way driver uses this port and the following nine ports for a total of 10 (8000 ~ 8009).



Be sure not to set a duplicate Node Address in the same Network Address group.

7.5.4 Error Codes

Reference  About the GP Ethernet Specific Error Codes, refer to the “Protocol Stack Error Codes”.

■ PLC SPECIFIC ERROR CODES

The PLC error codes are displayed by the “Host Communication Error (02:**:**:###:###)”, and are indicated in the left lower corner of the GP screen. (**:** indicates the PLC error codes and ###:### indicates the Network Address and Node Address.) PLC error codes are shown using 2-byte, Main Response Codes and Sub Response Code.

Host Communication Error (02::**:###:###)**

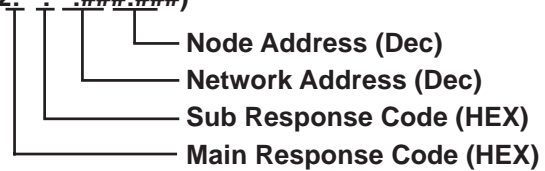

Reference  For more details about error codes, refer to Omron Communications Reference Manual for SYSMAC CS/CJ Series (Chapter5 FINS Commands, End Codes).

7.9 Protocol Stack Error Codes

Protocol Stack Error Codes are displayed on the GP as follows.

Host communication error (02:FE:**)

** represents one of the following error codes, from 00 to F0.

Error Code	Description	Notes
00	There is a setup error related to the IP address of your station at initialization.	
05	Initialization has failed.	
06	Cancelling of communications has failed.	
07	An attempt was made to establish a connection before initialization was successfully completed.	
08	Your station's port number is incorrect	
09	The destination station's port number is incorrect.	
0A	The IP address of the other station is incorrect.	
0B	The same port number is already being used by UDP for establishing the connection.	
0C	The same port number is already being used by TCP for establishing the connection.	
0D	Protocol stack has refused connection establishment.	
0E	Protocol stack has returned the unsuccessful establishment of a connection.	
0F	The connection has been shut down.	
10	All connections are busy. No connection is available.	
13	Your station was aborted by a different station.	
30	There was no reply from the protocol stack.	
32	There was no reply from the other station.	*1*2
40	No network information exists for the designated node.	*1
41	I/O memory type of the random read-out response data is incorrect.	*1
42	Network information does not exist.	
F0	Undefined error.	

*1 When using an OMRON Corporation CS1/CJ/CJ1M Series unit, the error code will appear on the GP screen as shown below. Also, behind the Ethernet error code will appear the designated Network and Node addresses.

Host Communication Error (02:FE:**:###:###)

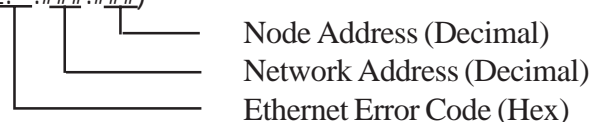

*2 When using a Hitachi Industrial Equipment Corporation's HIDIC H Series or a Schneider Corporation MODBUS TCP unit, the error code will appear on the GP screen as shown below. Also, behind the Ethernet error code will appear the designated Node address.

Host Communication Error (02:FE:**:###:###)

