

Device/PLC Connection Manuals



About the Device/PLC Connection Manuals

Prior to reading these manuals and setting up your device, be sure to read the "Important: Prior to reading the Device/PLC Connection manual" information. Also, be sure to download the "Preface for Trademark Rights, List of Units Supported, How to Read Manuals and Documentation Conventions" PDF file. Furthermore, be sure to keep all manual-related data in a safe, easy-to-find location.



2.20 Matsushita Electric Industrial

2.20.1 System Structure

The following describes the system structure for connecting the GP to Matsushita Electronics PLCs.

Reference The Cable Diagrams mentioned in the following tables are listed in the section titled "2.20.2 Cable Diagrams".

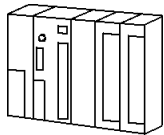
■ Panadac P7000 Series

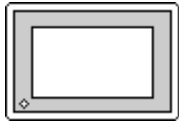
CPU	Link I/F	Cable Diagram	GP
			
P7000-PLC-001 P7000-PLC-031H P7000-PLC-031S P7000-PLC-A01	SIO module P7000-GC P-001	RS-232C (Cable Diagram 1)	GP Series

2.20.2 Cable Diagrams

The cable diagrams illustrated below and the cable diagrams recommended by Matsushita Electronics may differ, however, using these cables for your PLC operations will not cause any problems.



Ground your PLC's FG terminal according to your country's applicable standard. For details, refer to the corresponding PLC manual.



- **Connect the FG line of the Shield cable to either the GP or PLC, depending on your environment.**
- **For the RS-232C connection, use a cable length less than 15m.**
- **If a communications cable is used, it must be connected to the SG (signal ground).**

Cable Diagram 1 (RS-232C)

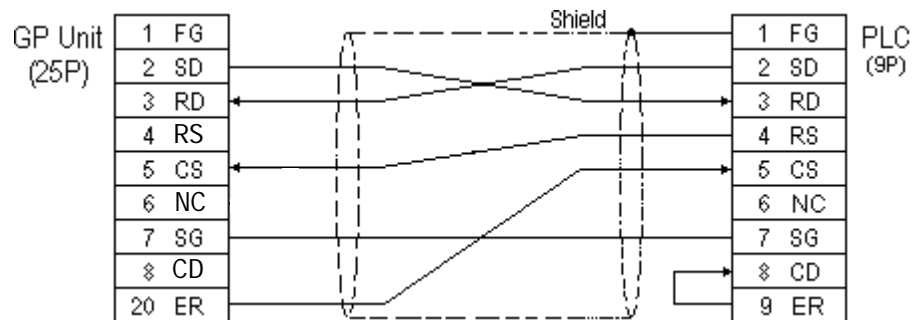

2.20.3 Supported Devices

The following describes the range of devices supported by the GP.

■ Panadac P7000 Series

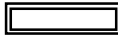
 Setup System Area here.

	Device	Bit Address	Word Address	Particulars
Bit Device	Data Register	IN0000 ~ IN07FF	IN0000 ~ IN007F	
	Input/Output Relay	OT0000 ~ OT07FF	OT0000 ~ OT007F	
	Internal Relay	RL0000 ~ RL07FF	RL0000 ~ RL007F	
	Holding Relay	KR0000 ~ KR03FF	KR0000 ~ KR003F	
	Link Relay	LK0000 ~ LK07FF	LK00000 ~ LK007F	
	Status Relay	ST0000 ~ ST01FF	ST0000 ~ ST001F	
	MC Status Relay	MS0000 ~ MS03FF	MS0000 ~ MS003F	
	Timer State Relay	TS0000 ~ TS01FF	TS0000 ~ TS001F	
	Timer-up Relay	TU0000 ~ TU01FF	TU0000 ~ TU001F	
	Count-up Relay	CU0000 ~ CU007F	CU0000 ~ CU0007	
	CPU Input Relay	CI0000 ~ CI01FF	CI0000 ~ CI001F	*1
	CPU Output Relay	C00000 ~ C001FF	C00000 ~ C0001F	
Word Device	Data Memory	M00000 ~ M07FFF	M0000 ~ M07FF	
	Link Register	LM00000 ~ LM07FFF	LM0000 ~ LM07FF	
	Timer (set value)	---	TM0000 ~ TM07FF	
	Timer (current value)		CT0000 ~ CT007F	
	Counter Value		TC0000 ~ TC01FF	*2
	Position Data	---	PM0000 ~ PM07FF	*3

*1 If a CPU module is not connected, these are handled as internal relays.

*2 This is a 32-bit device.

*3 If a 32-bit device NC module is not connected, this is handled as an internal relay.



If 2-word (32-bit) data are used, the vertical relation of addresses is shown as follows:

1	L (lower)
0	H (upper)

2.20.4 Environment Setup

The following lists Digital's recommended PLC and GP communication settings.

■ Panadac P7000 Series

GP Setup		Setting of SIO module	
Baud Rate	19200 bps	Baud Rate	19200 bps
Data Length	8 bits	Data Length	8 bits
Stop Bit	1 bit	Stop Bit	1 bit
Parity Bit	None	Parity Bit ON/OFF Even/Odd	None
Data Flow Control	ER Control	---	
Communication Format	RS-232C	---	
Unit No.	1	Slave address number	0
		Mode	COMMAND mode
		Delimiter	CR



The setting of the machine number is fixed, and cannot be specified on the PLC.



If there is any difference in the PLC and the GP settings, a communications error occurs.



The GP must be set to ER control.