

# Device/PLC Connection Manuals

---



## About the Device/PLC Connection Manuals

Prior to reading these manuals and setting up your device, be sure to read the "Important: Prior to reading the Device/PLC Connection manual" information. Also, be sure to download the "Preface for Trademark Rights, List of Units Supported, How to Read Manuals and Documentation Conventions" PDF file. Furthermore, be sure to keep all manual-related data in a safe, easy-to-find location.



## 15.2 JT Engineering Inc. Analyzers

### 15.2.1 System Structure

This section describes the system structure using JT Engineering Inc. JE-70 series analyzer and the GP/GLC/LT.

For the connection diagram, see "15.1.2 Connection diagram."

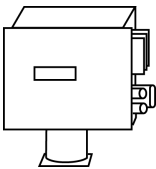
#### ■ JE-70 Series

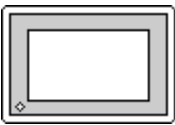
Analyzer	Cable Diagram	GP/GLC/LT
		
JE-70	RS-232C <Cable Diagram 1 > RS-422 (2-wire type) 1:1 <Cable Diagram 2> RS-422 (2-wire type) 1:n <Cable Diagram 3>	GP/GLS Series *1 LT Type C

\*1 For connectable GP/GLCs, see "15.1 Connectable Analyzers."

#### ◆ 1:1 RS-232C, RS-422

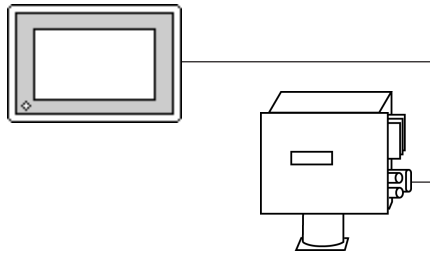

#### ◆ 1:n RS-422

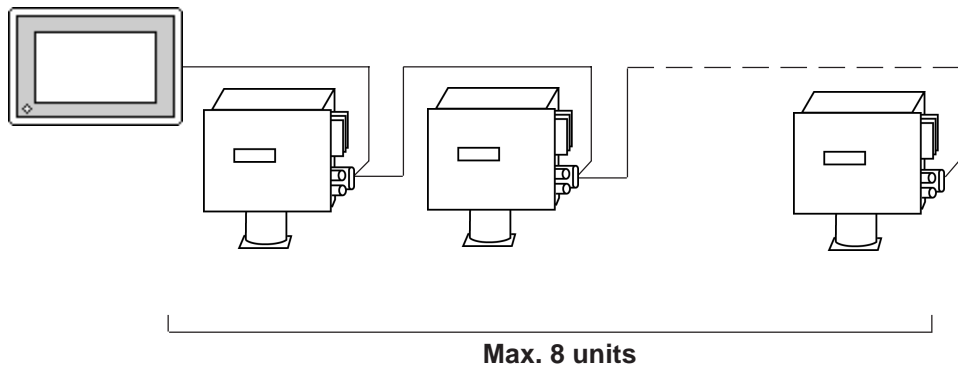

**15.2.2 Cable Diagram**

The following cable diagram may differ from the one recommended by JT Engineering, but using this design will not cause any operation problems.



- **Connect the GP/GLC/LT connector's FG wire to a shielded cable.**
- **The cable connected to the RS-232C port should be 15 meters or less.**
- **The cable connected to the RS-422 port should be 500 meters or less.**
- **When using a communication cable, be sure to connect the SG wire.**

**Cable Diagram 1 RS-232C**

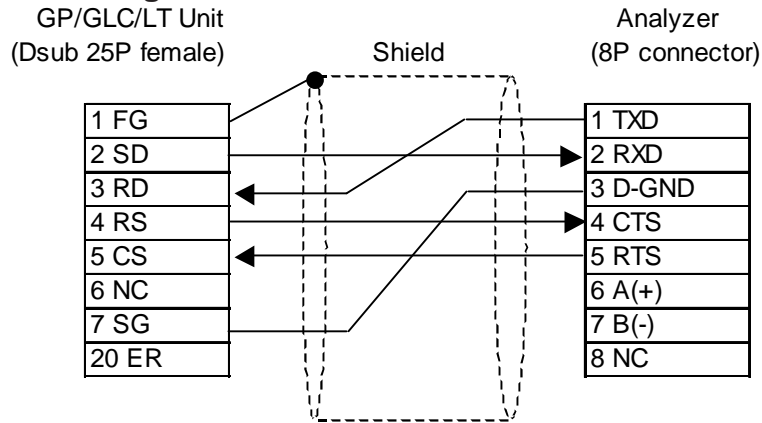

**Cable Diagram 2 1:1 RS-422**

- When using Digital's RS-422 connector terminal adapter, GP070-CN10-O

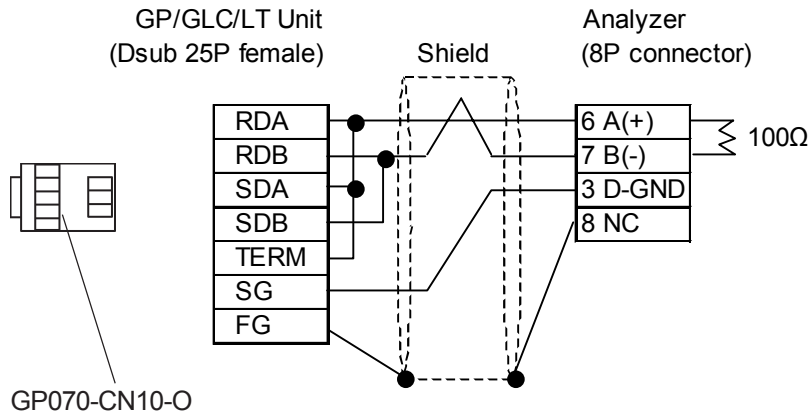

- When making your own cable connections

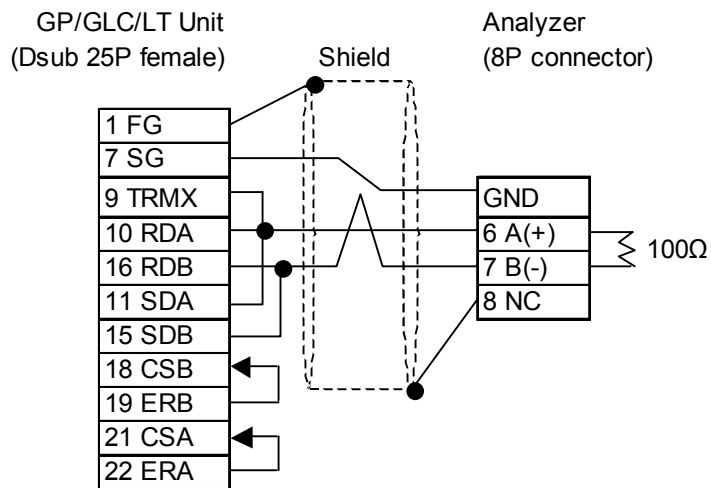

- When Pin Nos. 9 and 10 on the serial interface on the GP/GLC/LT side are connected to each other, a termination resistance of 100Ω is created between RDA and RDB.
- Use a shielded twisted-pair cable AWG#20 or larger.

**Cable Diagram 3 1:n RS-422**

- When using Digital's RS-422 connector terminal adapter, GP070-CN10-O

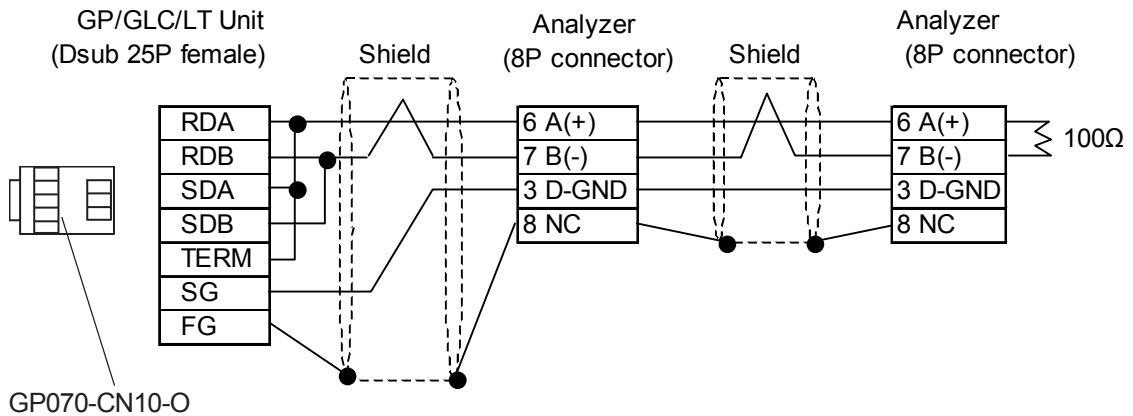

- When making your own cable connections

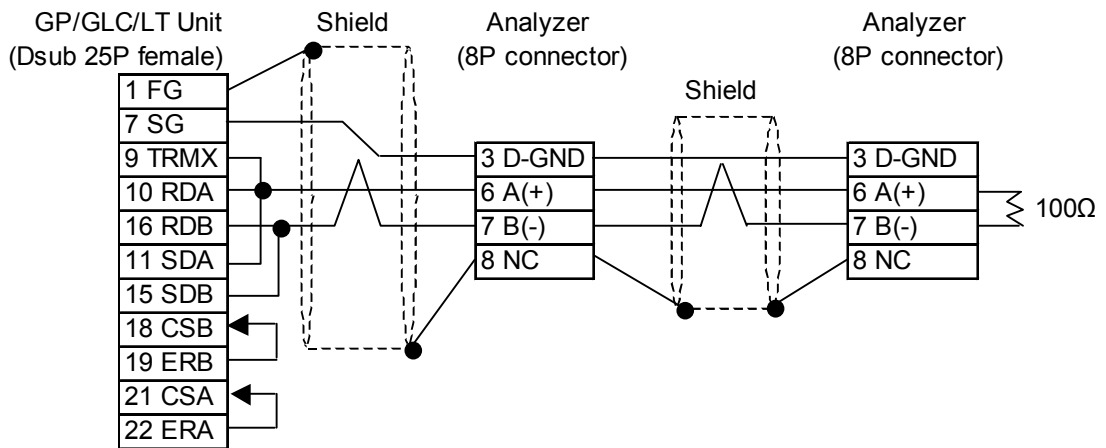

- **Up to 8 analyzers can be connected.**











- When Pin Nos. 9 and 10 on the serial interface on the GP/GLC/LT side are connected to each other, a termination resistance of 100Ω is created between RDA and RDB.
- Use a shielded twisted-pair cable AWG#20 or larger.

**15.2.3 Supported Device**

The following table describes the range of devices supported by the GP/GLC/LT.

■ **JE-70 Series**

 Setup System Area here.

Device	Bit Address	Word Address	Particulars	
Status Error	M0000 ~ M0031	M000 ~ M0016		L/H
Error	M0032 ~ M0079	M0032 ~ M0064		
Current Value	—	<span style="border: 1px solid black;">D0000 ~ D0160</span>		
Common Constant	—	R0000 ~ R0098		
Recipe Constant	—	R0100 ~ R2098		
Equipment-specific Data	—	R2100 ~ R2130		
Filter Constant	—	R2132 ~ R2198		
Correction Parameter	—	R2200 ~ R2346		

- For the details of each device, refer to the manual for JT Engineering's analyzer.

**Example of device settings**

When setting up Parts and Tags in GP-PRO/PBIII, specify the ID number of the analyzer when entering addresses.



- If no ID number is specified, the last entered ID number is assumed (the default value is 01).

**15.2.4 Environment Setup**

The following lists Digital's recommended analyzer and GP/GLC/LT communication setup.

**■ JE-70 Series**

GP/GLC/LT Setup		Analyzer Setup	
Baud Rate	38400 bps (fixed)	_____	_____
Data Length	8 bits (fixed)	_____	_____
Stop Bit	1 bit (fixed)	_____	_____
Parity Bit	Non (fixed)	_____	_____
Data Flow Control	ER Control (fixed)	_____	_____
Communication Format (using RS-232C)	RS-232C	DSN on the basis board	RS-232C
Communication Format (using RS-422)	RS-422 2-wire type	DSN on the basis board	RS-422
Unit No.	Analyzer Setup	ID number *1	1 ~ 8
Send Wait	20 msec or more	_____	_____

*\*1 The ID number of the analyzer may be specified in a range between 1 and 10. When the analyzer is used with the GP/GLC/LT, specify the ID number in a range between 1 and 8.*



- **To communicate with the JE-70 series, specify 20 ms or more for the transmission wait time of the GP/GLC/LT.**

**The transmission wait time should be specified using System Setup in GP-PRO/PBIII. Choose Extended Setup from Communication Setup and then specify the transmission wait time.**

**15.2.5 Error Code**

■ Analyzer error codes

◆ JE-70 Series

An error message such as "Host communication error (02:\*\*:##)" will display the lower left corner of GP/GLC/LT screen (\*\* stands for an error code specific to the analyzer).

Host communication error (02.\*\*.##)

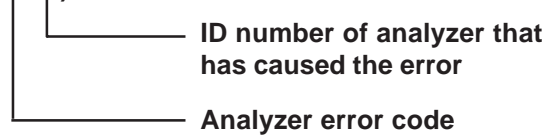

Error code	Description	Details
01	Checksum code error	The checksum code sent by the host is wrong.
02	Command error	The command (symbol) sent by the host is other than BR, WR, BW, WW, JR, QR, JW, QW, and TT.
03	Device number too large	The device number sent by the host is too large.
04	Word-based write to M-device	The host has issued a write request to the M-device using the WW or QW command.
05	Number of word devices is odd	When the host has issued a word-based write or read to word devices, the number of word devices is odd.
06	First address for word device is odd	When the host has issued a write or read request to a word device, the first address for the word address is odd.
07	Measurement recipe number is not registered yet	When the host has requested changing the recipe number for the measured components, that recipe number is not registered yet (the host has not written the recipe number).
08	Recipe number for display is not registered yet	When the host has requested changing the recipe number for display, that recipe number is not registered yet (the host has not written the recipe number).
09	Recipe number for output is not registered yet	When the host has requested changing the recipe number for output, that recipe number is not registered yet (the host has not written the recipe number).
0A	Recipe number of display is not measured yet	The host has requested changing the recipe number for display, but the recipe number after the change is not under measurement.
0B	Recipe number for output is not measured yet	The host has requested changing the recipe number for output, but the recipe number after the change is not under measurement.



