

Device/PLC Connection Manuals



About the Device/PLC Connection Manuals



Prior to reading these manuals and setting up your device, be sure to read the "Important: Prior to reading the Device/PLC Connection manual" information. Also, be sure to download the "Preface for Trademark Rights, List of Units Supported, How to Read Manuals and Documentation Conventions" PDF file. Furthermore, be sure to keep all manual-related data in a safe, easy-to-find location.

Fuji Electric Corporation Controllers

1 System Structure

The following describes the system configuration used when connecting the GP/GLC/LT to this Controller.

■ Micro-Controller X Series (Model:PXR)

Controller *1	Cable Diagram	GP/GLC/LT
		
PXR3□□□1-□□M00 PXR3□□□1-□□V00 PXR4□□□□-□□M00 PXR4□□□□-□□V00 PXR5□□□1-□□M00 PXR5□□□1-□□V00 PXR9□□□1-□□M00 PXR9□□□1-□□V00	RS-422 <Cable diagram 1>	GP/GLC series LT Type C
	RS-422 (1:n) <Cable diagram 2>	

*1 The Controller's model number "□" will change, according to the options selected. For model number details, refer to the PXR4 Series catalog. When connecting the Controller to a GP, the RS-485 (MODBUS) option "M00" or "V00" is required.

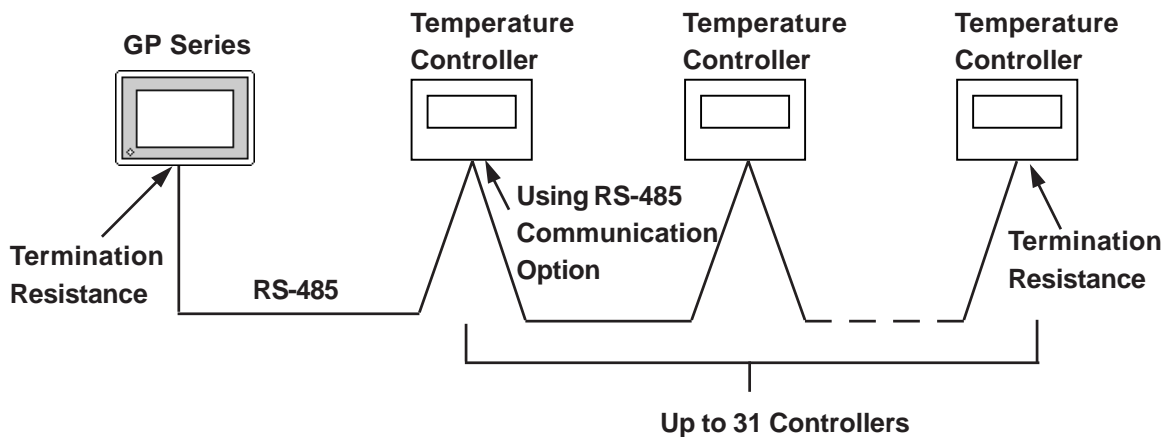

2 Cable Diagrams

The cable diagrams shown below and the cable diagrams recommended by Fuji Electric Co., Ltd. differ, however, using these cables for your Controller's operations will not cause any problems.



- **Ground your PLC's FG terminal according to your country's applicable standard.**
- **All RS-422 cables should be no more than 500 meters long.**
- **The Controller terminal number will differ depending on the type of CPU used.**

Signal Name	Terminal No.		
	PXR3	PXR4	PXR5/PXR9
+	15	7	1
-	14	8	2

■ Cable Diagram 1 (1:1) RS-422(2-wire type)

- Using Digital's RS-422 connector terminal adapter GP070-CN10-0

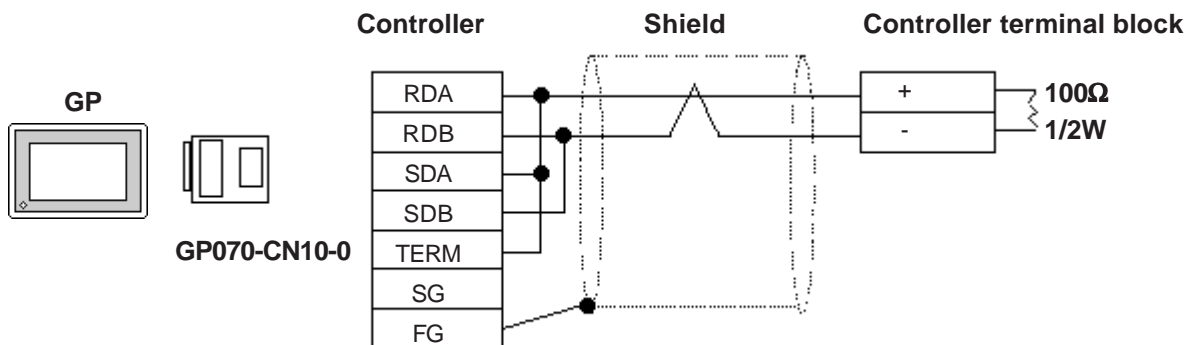

- Using Digital's RS-422 Cable GP230-IS11-0

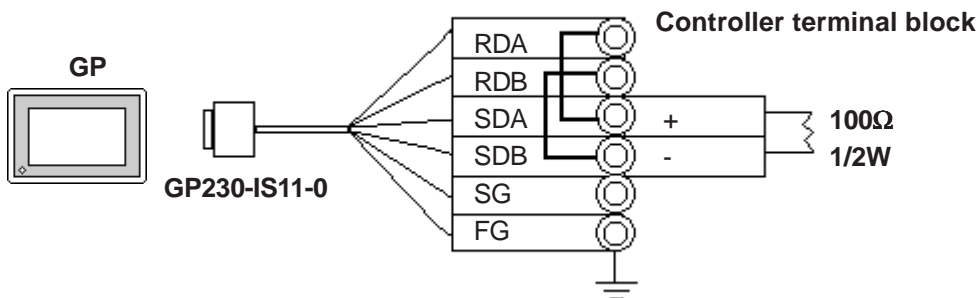

- **Be sure that RDA - SDA and RDB - SDB are both connected to the Controller terminal block.**



- **Since the SG and FG lines cannot be connected to the controller terminal block, be sure to cover them with insulating tape.**

- When making your own cables

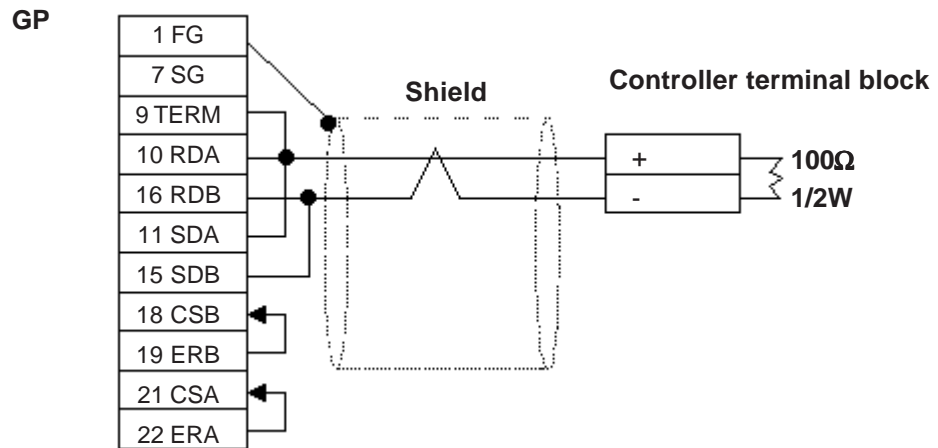

■ Cable Diagram 2 (1:n) RS-422 (2-wire type)

- Using Digital's RS-422 connector terminal adapter GP070-CN10-0

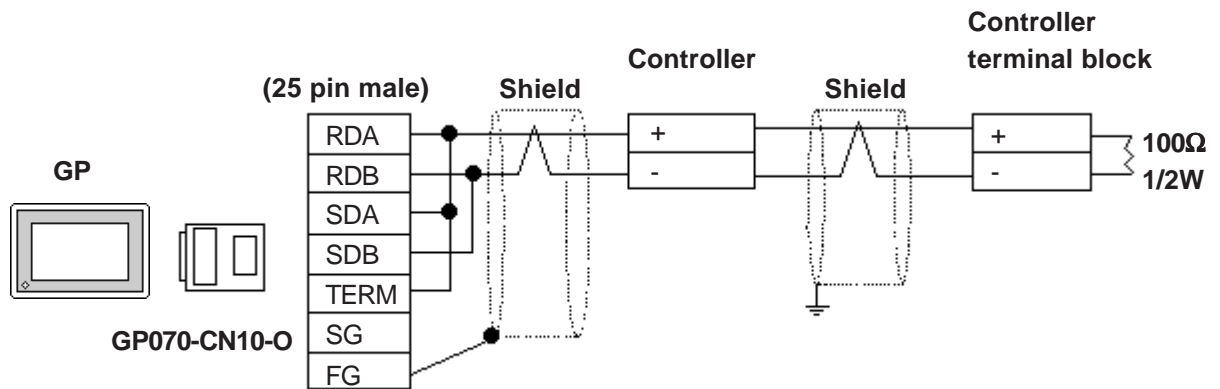

- Using Digital's RS-422 cable, GP230-IS11-0

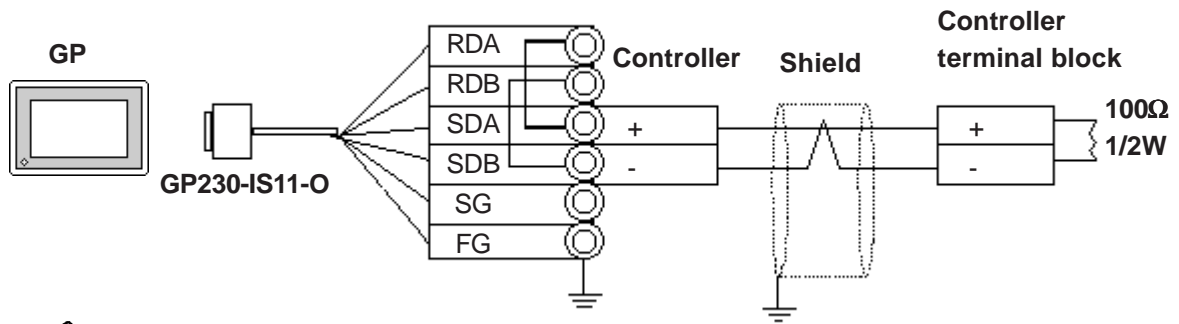

Note:

- Be sure that RDA - SDA and RDB - SDB are both connected to the Controller terminal block.



- *Since the SG line cannot be connected to the controller terminal block, be sure to cover them with insulating tape.*

- When making your own cable connections

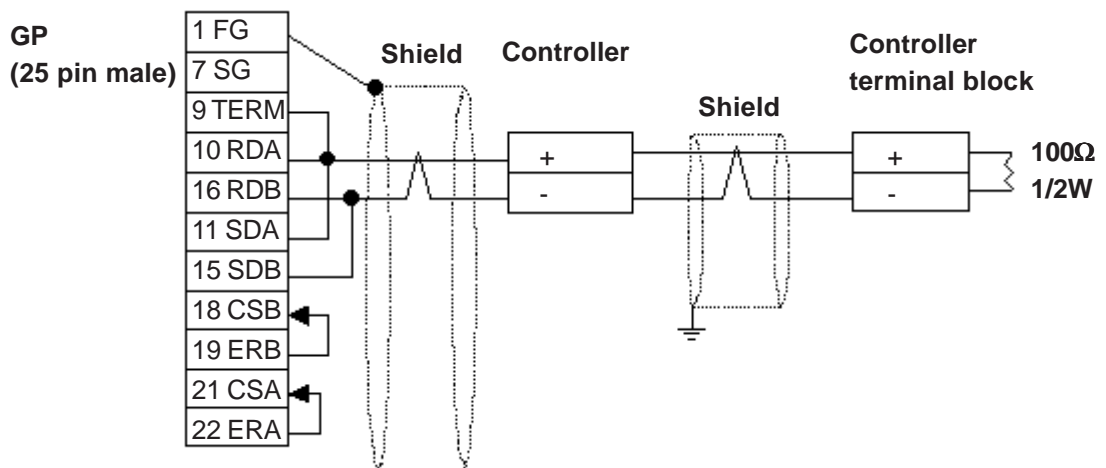

3 Supported Devices

The following list shows the range of devices supported by the GP/GLC.

■ Micro-Controller X Series (Model:PXR)

Device	Bit Address	Word Address	Comments	
Parameter	00001	_____	*1	H/L
	10001 ~ 10016	10001	*2	
	3000100 ~ 3001515	30001 ~ 30015	Internal Calculation Value *2	
	4000100 ~ 4011315	40001 ~ 40113	Internal Calculation Value *1	
	3100100 ~ 3101515	31001 ~ 31015	Engineering Unit *2	
	4100100 ~ 4111315	41001 ~ 41113	Engineering Unit *1	

*1 Addresses 00001, 40001 and 41001 are used to store write commands (FIX Processing) in non-volatile memory. The non-volatile memory's write is performed via the writing of "Write Value 1". FIX processing lasts approximately 5 seconds. The Display Communication cannot be performed for 5 seconds if there are any Read-out Tags on the same screen.

Reference Instruction Manual for Fuji Electric Corporation's MICRO CONTROLLER X COMMUNICATION FUNCTION (RS-485 MODBUS), "FIX Processing"



- During the writing of data to non-volatile memory, do not turn off the Controller's power. If the Controller's power is cut, the data in non-volatile memory will be destroyed, thereby disabling the Controller.

*2 Data write is not possible.



- In the GP, the Controller's parameters are set via the Coil No. and Register No. For each Coil No. (00001~, 10001~) the last digit is recognized as the device. For Register No.s (30001~, 40001~, 31001~, 41001~) the last two digits are recognized as the device.
- For information about data item types and numbers, refer to the Instruction Manual for Fuji Electric Co., Ltd.'s MICRO CONTROLLER X COMMUNICATION FUNCTION (RS-485 MODBUS), "CHAPTER 7 ADDRESS MAP AND DATA FORMAT"
- The GP supports two types of Address Maps, the "Engineering Unit Address Map" and the "Internal Calculation Value Address Map".

The following data shows the memory maps for each parameter.

- When using Bit Data

Bit Data (Read Only) : Function [02H]

Relative Address	Coil No.	Type	Memory Contents	Read-out Data
0000H	10001	Bit	Alarm1 ON/OFF	0:Alarm1 OFF, 1:Alarm1 ON
0001H	10002		(Reserved)	
0002H	10003		(Reserved)	
0003H	10004		(Reserved)	
0004H	10005	Bit	Alarm2 ON/OFF	0:Alarm2 OFF, 1:Alarm2 ON
0005H	10006		(Reserved)	
:	:	:	:	:

The item Nos. here are the GP addresses.

Ex. For the parameter “Alarm1 ON/OFF” of Coil No. 10001, the GP’s designated address is as follows. Use the first digit of the Coil No. (00001~, 10001~) to designate the device.

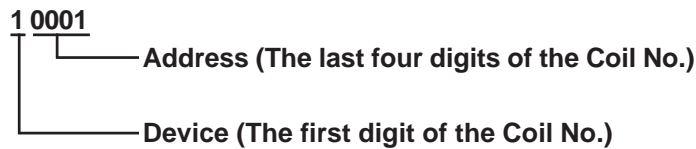

Ex. For the parameter “front surface control SV data” of Register No. 41003, the GP’s designated address is as follows. Use the first two digits of the Register No.s 30001~, 40001~, 31001~ and 41001~ to designate the device.

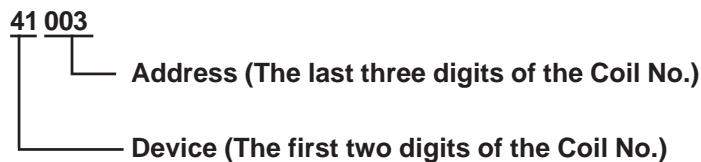

- The Controller’s parameter data, when data transfer is performed, will have no decimal places. Thus, in the GP, processing must be performed to correct the data. For example, if a numeric display (N-tag) is used that includes decimal places, the “Data Type” and “No. of Decimals” settings must be used. Also, when writing data to a Controller, it is necessary to write decimal values as integers.

Ex. Register No. 41025’s “Output 1 Lower Limit”

Controller Display/Setting Value : 3.00%

GP value/setting : 300



Reference Also, refer to “Instruction Manual for Fuji Electric Co., Ltd.’s MICRO CONTROLLER X COMMUNICATION FUNCTIONS (RS-485 MODBUS)” for details (with/without a decimal point) about data item setting value ranges.



- When setting Parts or Tags in the screen editor software, the Controller communication unit No. can be specified during address input. If a communication unit No. is not indicated, the previously entered communication unit No. is automatically used. (The default value is 1)

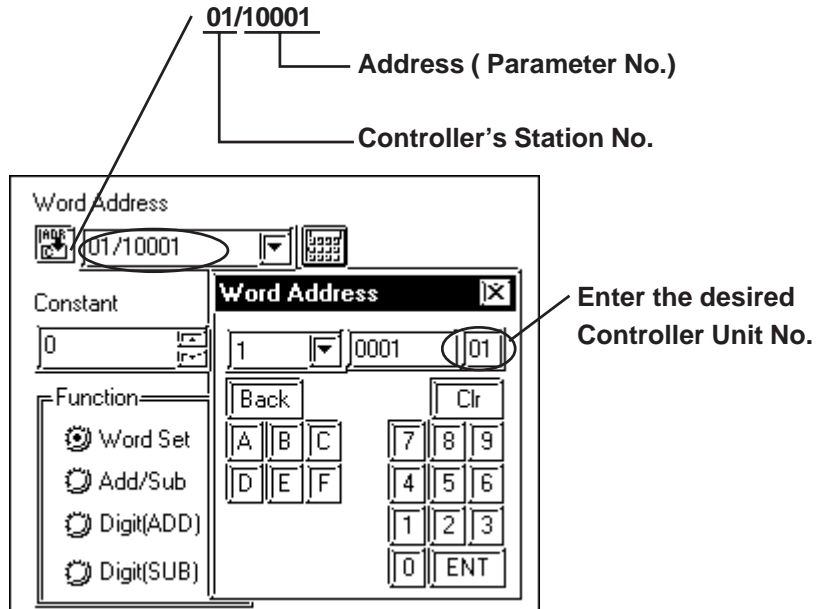

- **GP/GLC/LT's System Area (LS0 to LS19) Settings**

The GP/GLC/LT's system area (20 words) cannot be allocated to the Controller's own data area. Even though you can enter the system area settings via the GP's screen editor software or via the GP/GLC/LT's OFFLINE screen, it is impossible to actually allocate the system area to the Controller's data area.

4

Environment Setup

The following table lists the recommended Controller and GP/GLC/LT communication settings.

■ **Micro-Controller X Series (Model:PXR)**

GP/GLC/LT Settings		Controller Settings	
Baud Rate	9600 bps (Fixed)	-----	-----
Data Length	8 bits (Fixed)	-----	-----
Stop Bit	1 bit (Fixed)	-----	-----
Parity Bit	Odd	Parity Settings (CoM)	0 : Odd
Data Flow control	ER	-----	-----
Communication Format (using RS-422)	2-wire type	-----	-----
Unit No. ^{*1}	1	Unit Station No. (Stno)	1

**1 It is possible to set a Controller communication unit No. from 0 to 255, however, the GP/GLC/LT can only be set from 1 to 32. Zero cannot be used because it means "Communication function stop". The Read-in area can be used in the Controller that has set the Unit No. here.*

5 Error Codes

Controller error codes are displayed by the “Host Communication Error (02:**:##)”, and indicated in the left lower corner of the GP screen ** indicates the Controller’s error code, and ## indicates the number of the Controller unit. However, when the PLC is not correctly connected (02:FF), the unit number will not be shown.

Error Code	Meaning
01	Illegal function
02	Illegal data address
03	Illegal data value

For more details about error codes, see

Reference *Instruction Manual for Fuji Electric Co., Ltd.’s MICRO CONTROLLER X COMMUNICATION FUNCTION (RS485 MODBUS)*