

Device/PLC Connection Manuals



About the Device/PLC Connection Manuals

Prior to reading these manuals and setting up your device, be sure to read the "Important: Prior to reading the Device/PLC Connection manual" information. Also, be sure to download the "Preface for Trademark Rights, List of Units Supported, How to Read Manuals and Documentation Conventions" PDF file. Furthermore, be sure to keep all manual-related data in a safe, easy-to-find location.

Fuji Electric Corporation

1 System Structure



The following describes the system structure for connecting the GP to Fuji Electric Corporation, Ltd. PLCs.

Reference Cable Diagrams mentioned in the following tables are listed in the section titled "2.3.2 Cable Diagrams".



In the LS area, 32-bit devices are not supported. Therefore, when System Area addresses are allocated to BD, DL, or W33 devices, only System Area (LS0 to LS19) addresses can be used. Other LS areas, such as the user area, etc. should not be used.

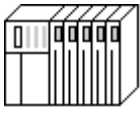
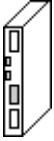

■ MICREX-F Series (using Link I/F)

CPU	Link I/F	Cable Diagram	Cables	GP
	 PC I/F Module/ Generic I/F			
F80H, F120H, F250	FFU-120B PC Interface Module	RS-232C (Cable Diagram 1) RS-422 (Cable Diagram 2)	RS-232C Digital's GP410-IS00-O (5m)	GP Series
F70S (NC1P-S0)	NC1L-RS2 (Generic Interface) ^{*1}	RS-232C (Cable Diagram 1)	Digital's GP410-IS00-O (5m)	



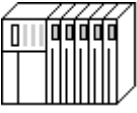
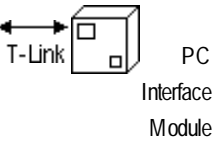

**1 When expansion units are attached via a T-Link system to a main PLC unit, and more than 2 link units are attached to the expansion unit, the GP unit can be attached to only one of the link units. (Simultaneous connection to 2 link units is not possible.)*

Simultaneous connection to 2 link units is possible only when they are attached to the main PLC unit.



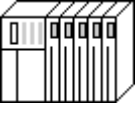

■ **MICREX-F Series <T-link>** (using Link I/F)

CPU	Link I/F	Cable Diagram	Cables	GP
				
F80H, F120H, F250 F30, F50, F60, F80, F81, F120 F120S, F200	FFK120A-C10	RS-232C (Cable Diagram 1) RS-422 (Cable Diagram 2)	RS-232C Digital's GP410-IS00-O (5m)	GP Series
	FFK100A-C10	RS-232C (Cable Diagram 3)		

■ **MICREX-F Series (FLT-ASFK)** (CPU Direct Connection)

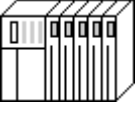
CPU	Adapter	Cable Diagram	Cables	GP
	PC Loader adapter 			
F80H, F250, F120H	Fuji Electric's FLT-ASFK	RS-232C (Cable Diagram 1)	RS-232C Digital's GP410-IS00-O	GP Series

■ **MICREX-SX Series**

CPU	Link I/F	Cable Diagram	Cables	GP/GLC
	PC Loader adapter 			
NP1PS-32 NP1PS-74 NP1PS-117 NP1PS-32R NP1PS-74R NP1PS-117R NP1PH-08 NP1PH-16	Loader Connection Connector on CPU	RS-232C (Cable Diagram 5)	Fuji Electric's NW0H-CNV + NP4HCB2 (2m)	GP/GLC/ST Series, Factory Gateway
	NP1L-RS1	RS-232C (Cable Diagram 6) RS-422 4-wire (Cable Diagram 7) RS-422 2-wire (Cable Diagram 8)		
	NP1L-RS2	RS-232C (Cable Diagram 6)		
	NP1L-RS4	RS-422 4-wire (Cable Diagram 7) RS-422 2-wire (Cable Diagram 8)		

■ Connection Structure Diagram

◆ CPU Direct Connection

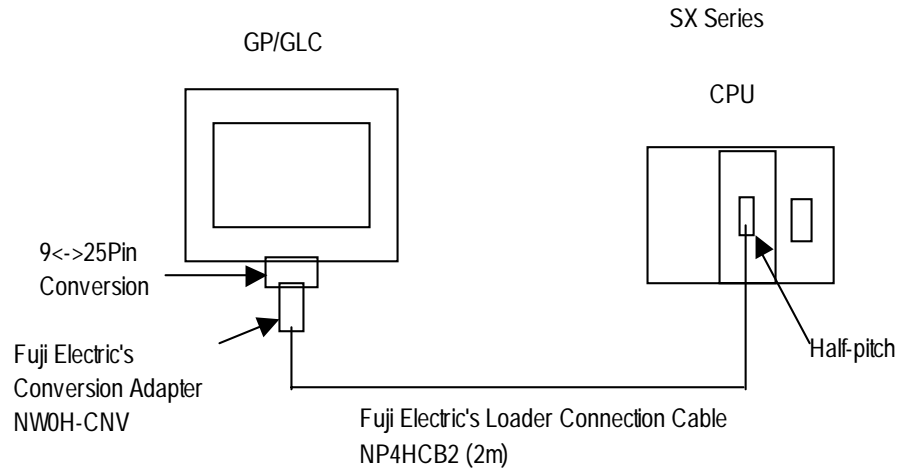



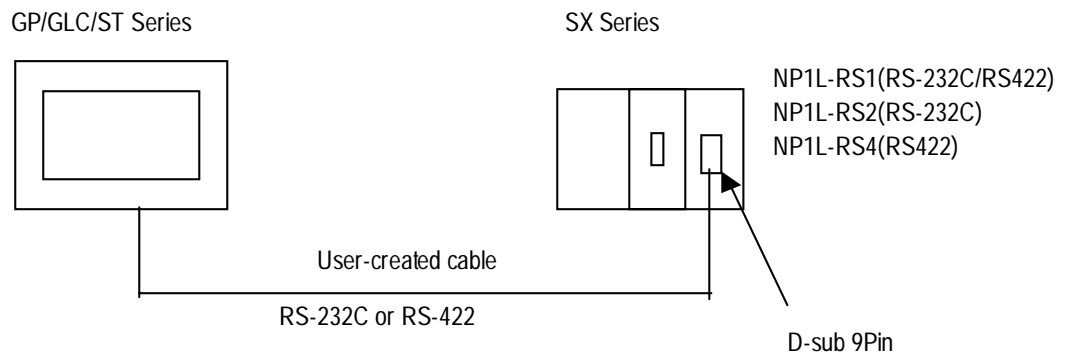

Note: The GP interface's 9Pin <-> 25Pin converter is not required when connecting the PLC unit to ST series units.

◆ Link Unit Connection

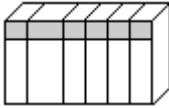



■ **FLEX-PC Series** (using Link I/F)

CPU	Link I/F	Cable Diagram	Cables	GP
	 General SIO Unit/ General I/F Module			
NB1, NB2, NB3	NB-RS1-AC (Generic RS-232C/ 485 SIO unit)	RS-232C (Cable Diagram 1) RS-422 (Cable Diagram 2)	RS-232C Digital's GP410-IS00-O (5m)	GP Series
NJ	NJ-RS2 (Generic RS-232C SIO interface module)	RS-232C (Cable Diagram 1)	Digital's GP410-IS00-O (5m)	
	NJ-RS2 (Generic RS-485 SIO interface module)	RS-422 (Cable Diagram 2)		
NS	NS-RS1 (Generic RS-232C/485 interface module)	RS-232C (Cable Diagram 1) RS-422 (Cable Diagram 2)	RS-232C Digital's GP410-IS00-O (5m)	

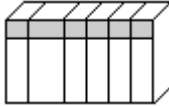

Places noted as RS-422 can also use RS-485 on the PLC side.

■ **FLEX-PC Series** (CPU Direct Connection)

CPU	Cable Diagram	GP
		
NB1, NB2, NB3, NJ, NS	RS-422 (Cable Diagram 4)	GP Series



When using Digital's T-Link I/F Unit, refer to the GP-*50/70 Series T-Link I/F Unit User's Manual.

2 Cable Diagrams

The cable diagrams illustrated below and the cable diagrams recommended by Fuji Electric Co., Ltd. may differ; in any case, using these cables for your PLC operations will not cause any problems.



Ground your PLC's FG terminal according to your country's applicable standard. For details, refer to the corresponding PLC manual.



- **Connect the FG line of the Shield cable to either the GP or PLC, depending on your environment. When using a connector hood and grounding the FG line, be sure to use an electrical conductor.**
- **For the RS-232C connection, use a cable length less than 15m.**
- **If a communications cable is used, it must be connected to the SG (signal ground).**

Cable Diagram 1 (RS-232C)

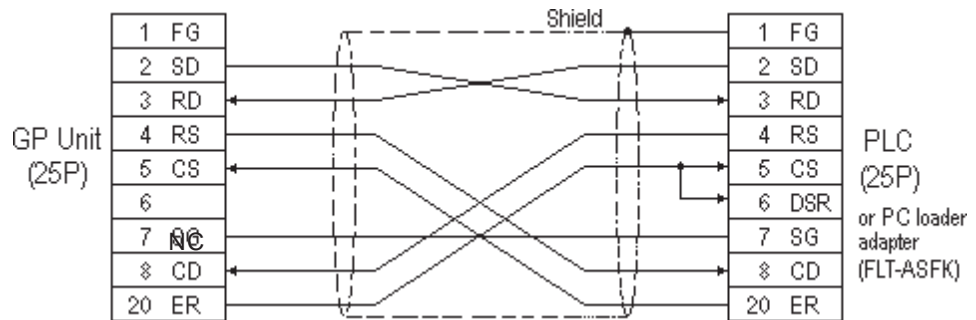

Cable Diagram 2 (RS-422)



Turn on the Termination Resistor switch, on the PLC side.

- When using Digital's RS-422 connector terminal adapter GP070-CN10-0

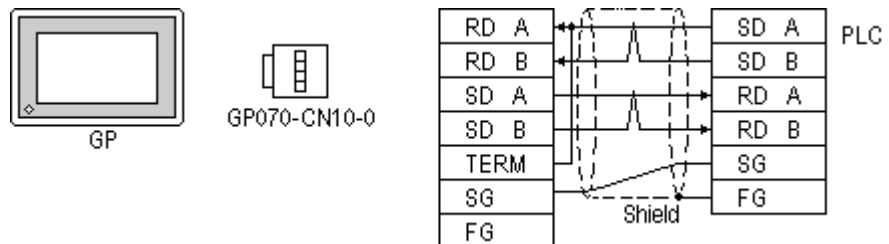

- When using Digital's RS-422 Cable, GP230-IS11-0

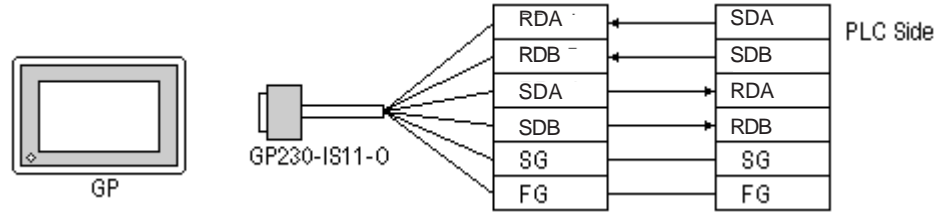

- When making your own cable connections

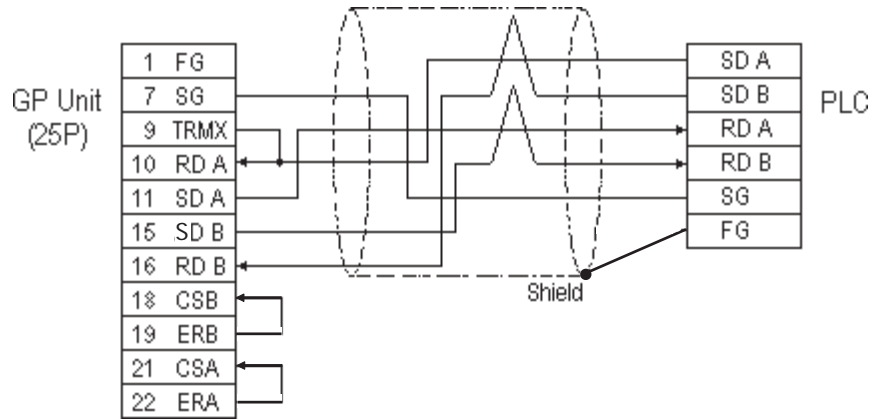

- When making your own cable connections, we recommend using Hitachi Densen's CO-SPEV-SB(A)3P*0.5S cable.
- When connecting the #9 and #10 pins in the GP Serial I/F, a termination resistance of 100Ω is added between RDA and RDB.

Cable Diagram 3 (RS-232C)

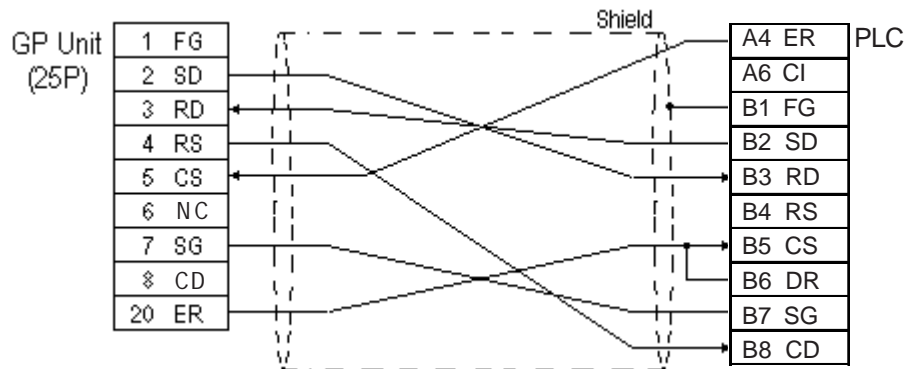

Cable Diagram 4 (RS-422)

Note:

For the PLC side connector (modular-jack) you can use Hirose's TM11P-88P.

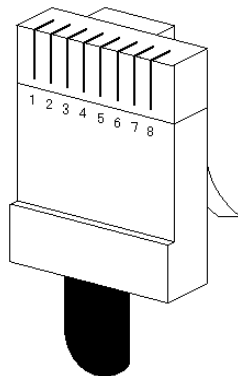

The pin numbers of the modular-jack for the connection diagrams below are based on the order described in the figure at the left.

- When using Digital's RS-422 connector terminal adapter GP070-CN10-0

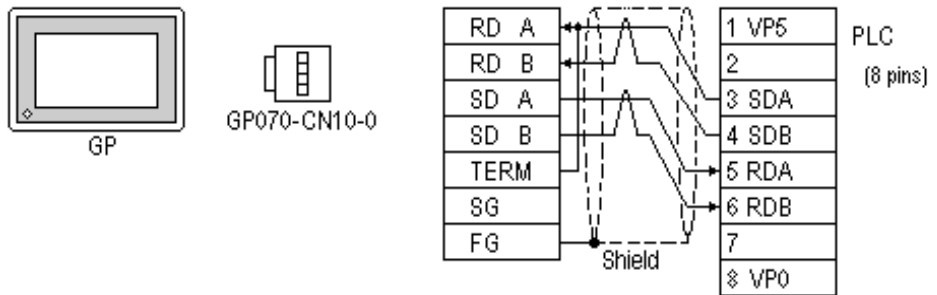

- When using Digital's RS-422 Cable, GP230-IS11-0

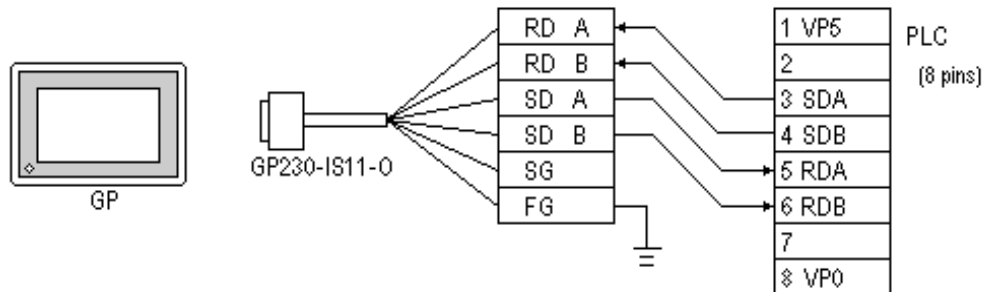

- When making your own cable connections

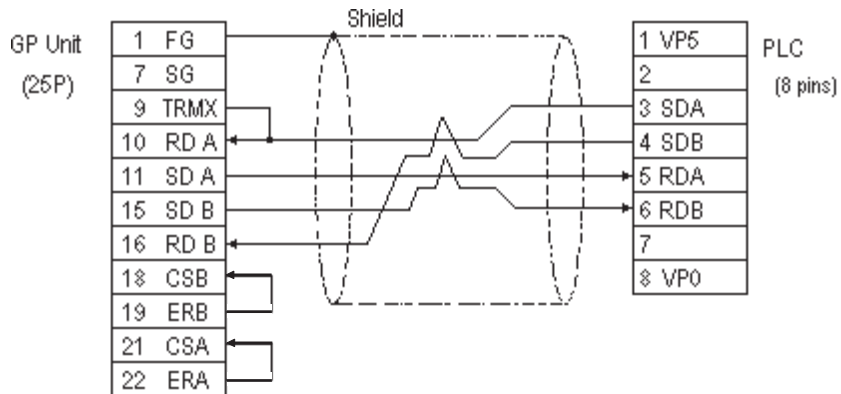

Note:

When connecting the #9 and #10 pins in the GP Serial I/F, a termination resistance of 100Ω is added between RDA and RDB.

Cable Diagram 5 (RS-232C)

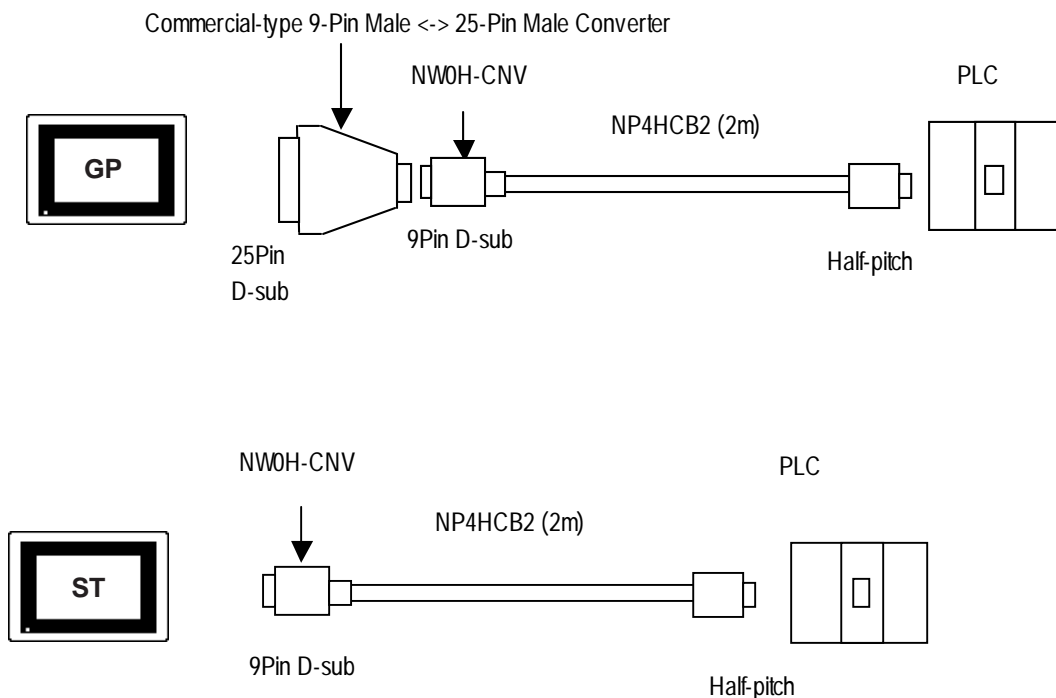

■ D-sub 25Pin <-> D-sub 9Pin Conversion Adapter Specifications

- Straight connection type
- D-sub 25 pin male Lock-screw (mm)
- D-sub 9 pin male Lock-nut (inch)

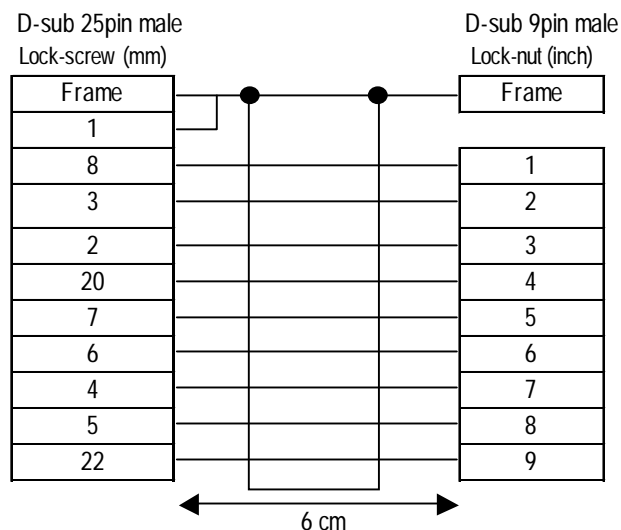

<Adaptor: Roas Co. Model No. ZA-403>

Cable Diagram 6 (RS-232C)

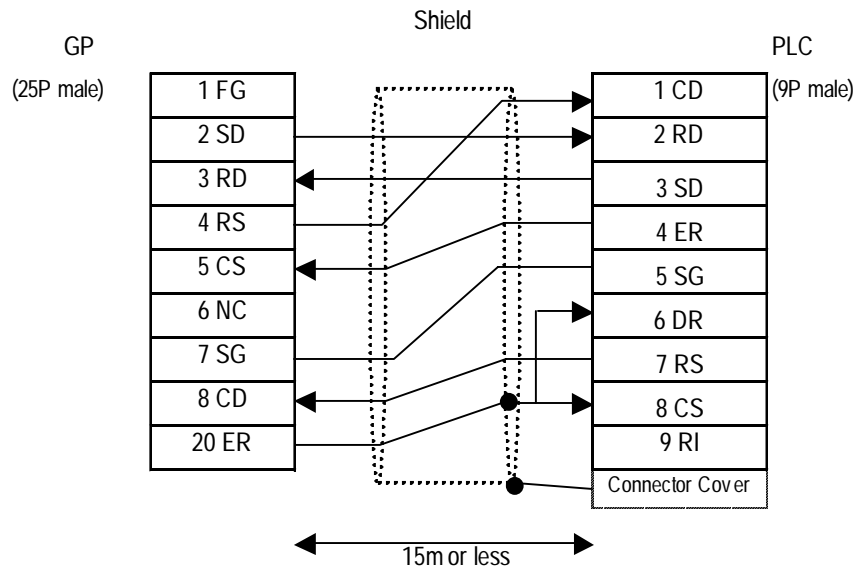

Cable Diagram 7 (RS-422, 4-wire)



- Set up the PLC interface's termination resistance via the unit's dip switch.
- The cable length should be 600m or less.
- When using Digital's RS-422 Connector Terminal Adapter (GP070-CN10-O)

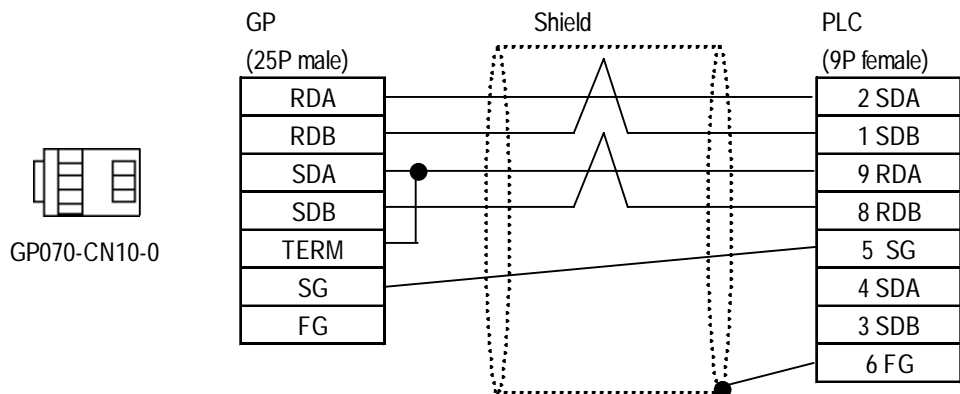

- When making your own cable

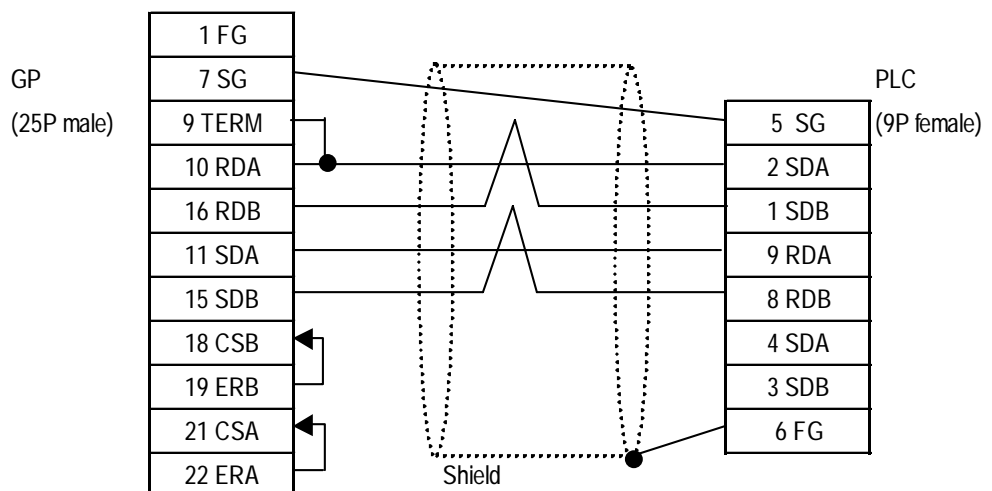

Cable Diagram 8 (RS-422, 2-wire)

- When using Digital's RS-422 Connector Terminal Adapter (GP070-CN10-O)

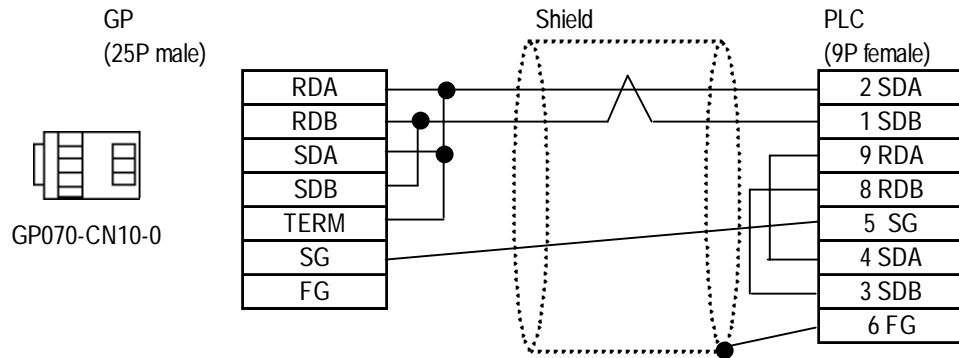

- When making your own cable

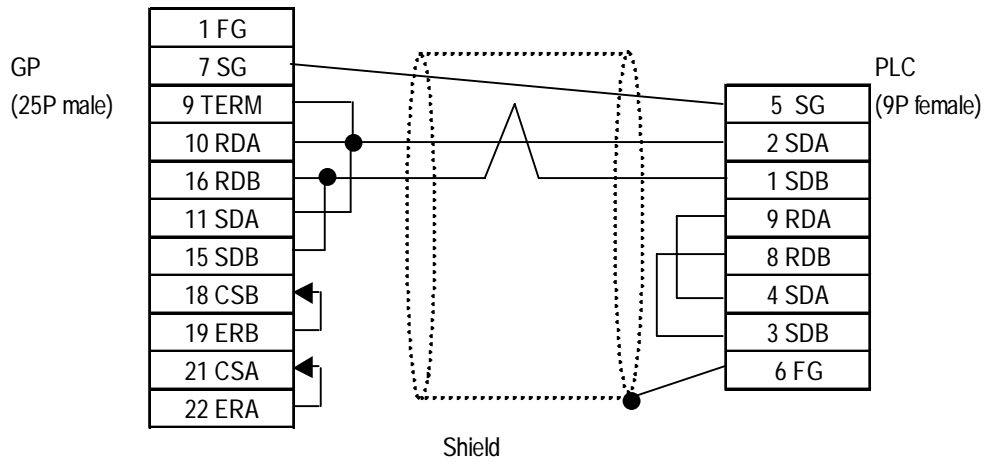

For ST Series units, pin numbers vary as indicated by the following table.

GP Pin No.	GP Signal Name	ST Signal Name	ST Series Pin No.
1	FG	—	Connector Shell
7	SG	GND	5
10	RDA	RXA	1
11	SDA	TXA	3
15	SDB	TXB	7
16	RDB	RXB	2
18	CSB	CSB	6
19	ERB	ERB	9
21	CSA	CSA	8
22	ERA	ERA	4

3

Supported Devices

The following describes the range of devices supported by the GP.

■ **MICREX-F Series**

Setup System Area here.

Device	Bit Address	Word Address	Particulars
I/O Relay	B0000 ~ B511F	WB0000 ~ WB0511	*1
Direct I/O	---	W24.0000 ~ W24.0159	
Auxiliary Relay	M0000 ~ M511F	WM0000 ~ WM0511	*1
Keep Relay	K0000 ~ K063F	WK000 ~ WK063	*1
Differential Relay	D0000 ~ D063F	WD000 ~ WD063	*1 *4
Link Relay	L0000 ~ L511F	WL000 ~ WL0511	*1
Special Relay	F00000 ~ F4095F	WF0000 ~ WF4095	*1 *4
Announce Relay	A00000 ~ A4095F	WA0000 ~ WA4095	*1 *4
Timer 0.01 sec	T0000 ~ T0511	---	
Timer 0.1 sec	T0512 ~ T1023	---	
Counter	C0000 ~ C0255	---	
Timer 0.01 sec (current value)	---	TR0000 ~ TR0511	
Timer 0.01 sec (setup value)	---	TS0000 ~ TS0511	
Timer 0.1 sec (current value)	---	W9.000 ~ W9.511	
Counter (current value)	---	CR0000 ~ CR0255	
Counter (setup value)	---	CS0000 ~ CS0255	
Data Memory	---	BD0000 ~ BD4095	[Bit 31]
	---	DI0000 ~ DI4095	[Bit 31]
	---	SI0000 ~ SI4095	[Bit 15]
File Memory	---	W30.0000 ~ W30.4094	[Bit 15] *2
	---	W31.0000 ~ W31.4094	[Bit 15] *2
	---	W32.0000 ~ W32.4094	[Bit 15] *2
	---	W33.0000 ~ W33.4094	[Bit 31] *3
	---	W34.0000 ~ W34.4094	[Bit 31] *3

H/L

* 1 The MSB (most significant bit) of a word device corresponds to bit 0 of the device, and the LSB (least significant bit) corresponds to bit F.

E.g. When hexadecimal data **0001** is written to a Word device address

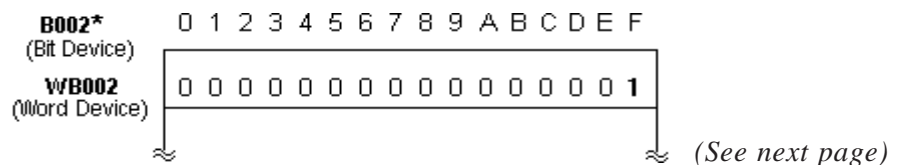

(from previous page)

- * 2 Define and use 16 bit length data.
- * 3 Define and use 32 bit length data.
- * 4 This device cannot write. Use it only for reading.



- **In the LS area, 32-bit devices are not supported. Therefore, when System Area addresses are allocated to BD, DL, or W33 devices, only System Area (LS0 to LS19) addresses can be used. Other LS areas, such as the user area, etc. should not be used.**
- **When using the GP-570VM or GP-870VM, do not allocate the System Area for BD, DI, or W33 word addresses.**
- **Certain PLC models and versions may not be able to perform bit reading or writing.**

F30 not possible with versions 0.9 or lower
F50 not possible with versions 1.4 or lower
F50H not possible with versions 0.7 or lower
F80 not possible with any version
F81 not possible with any version
F120 not possible with any version
F200 not possible with any version

Check the information plate on the side of the PLC to find the PLC's version information.

When processing 16-bit single word data:

Internally, the GP basically processes 1 word as 16 bit length data. As a result, the reading and writing of 32 bit length data devices are processed as follows:

Reading	From 32 bit data, reads data only from the bottom 16 bits.
Writing	From 32 bit data, writes data only to the bottom 16 bits, as 0 is written to the top 16 bits.

E.g. When data is **12345678** hex.

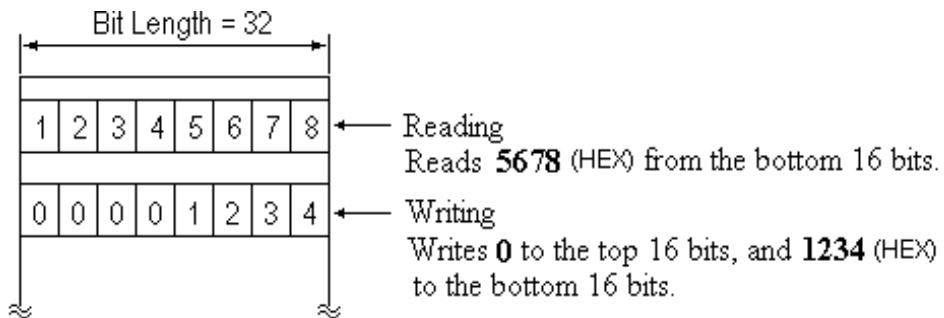

When processing 2 word 32-bit data:

Two word addresses at bit length 16 are necessary to handle 32 bit long data, but when using a 32 bit device, only one word address needs to be specified.

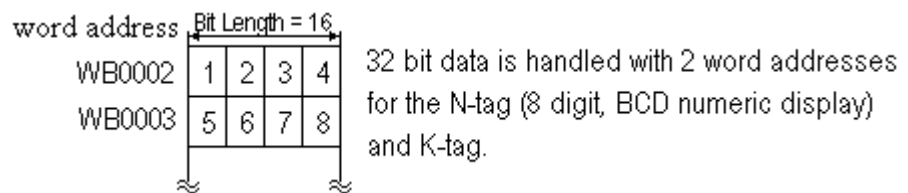
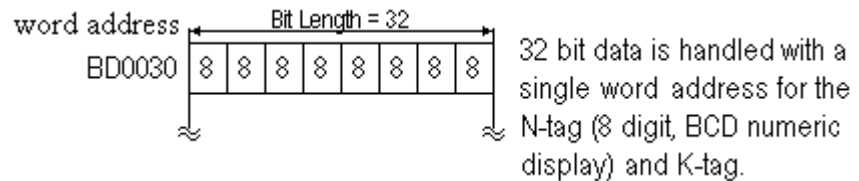
When using a 16 bit device**When using a 32 bit device****■ FLEX-PC Series**
 Setup System Area here.

Device	Bit Address	Word Address	Particulars	
Input Relay	X0000 ~ X07FF	WX0000 ~ WX07F	L/H	
Output Relay	Y0000 ~ Y07FF	WY0000 ~ WY07F		
Internal Relay	M0000 ~ M03FF	WM000 ~ WM03F		
Extended Internal Relay	M0400 ~ M1FFF	WM040 ~ WM1FF		
Latch Relay	L0000 ~ L03FF	WL000 ~ WL03F		
Extended Latch Relay	L0400 ~ L1FFF	WL040 ~ WL1FF		
Special Relay	M8000 ~ M81FF	WM800 ~ WM81F		
Timer	T0000 ~ T03FF	---		
Counter	C0000 ~ C01FF	---		
Timer (current value)	---	T0000 ~ T03FF		
Timer (setup value)	---	TS0000 ~ TS03FF		
Counter (current value)	---	C0000 ~ C01FF		
Counter (setup value)	---	CS0000 ~ CS01FF		
Data Register	---	D0000 ~ D2FFF		Bit 5
Special Register	---	D8000 ~ D837F		Bit 5
Link Register	---	W0000 ~ W3FFF		Bit 5
File Register	---	R0000 ~ R7EFF	Bit 5	

* 1 Define and use 16 bit length data.



- **Cannot read the *Timer* and *Counter* setup value. However, the write operation is possible only when the PLC is in program mode.**
- **When the *Timer* and *Counter* setup values are written from the GP, the ladder is changed so that the setup value uses a relative reference. For this reason, be careful when the setup value for the *Timer* and *Counter* uses an indirect ladder. Normally, *access* is recommended for indirectly referenced devices.**

■ MICREX-SX Series

Setup System Area here.

Device	Bit Address	Word Address	Description
Input Memory	%IX 1.0.0 ~ %IX 238.3.15	%IW1.0 ~ %IW238.3	*1
Output Memory	%QX 1.0.0 ~ %QX 238.3.15	%QW1.0 ~ %QW 238.3	*1
Standard Memory	%MX□.1.0.0 ~ %MX□.1.65535.15	%MW□.1.0 ~ %MW□.1.65535	*2,*3,*4
	%MX□.1.65536.0 ~ %MX□.1.131071.15	%MW□.1.65536 ~ %MW□.1.131071	*2,*3,*4
	%MX□.1.131072.0 ~ %MX□.1.196607.15	%MW□.1.131072 ~ %MW□.1.196607	*2,*3,*4 *2,*3,*4
	%MX□.1.196608.0 ~ %MX□.1.262143.15	%MW□.1.196608 ~ %MW□.1.262143	*2,*3,*4 *2,*3,*4
Retain Memory	%MX□.3.0.0 ~ %MX□.3.32768.15	%MW□.3.0 ~ %MW□.3.65535	*2,*3,*4
	%MX□.3.65536.0 ~ %MX□.3.131071.15	%MW□.3.65536 ~ %MW□.3.131071	*2,*3,*4 *2,*3,*4
	%MX□.3.131072.0 ~ %MX□.3.196607.15	%MW□.3.131072 ~ %MW□.3.196607	*2,*3,*4 *2,*3,*4
	%MX□.3.196608.0 ~ %MX□.3.260095.15	%MW□.3.196608 ~ %MW□.3.260095	*2,*3,*4 *2,*3,*4
System Memory	%MX□.10.0.0 ~ %MX□.10.512.15	%MW□.10.0 ~ %MW□.10.512	*2

L/H

*1 Input/Output Memory Address Designation is as shown below.

• BitDesignation

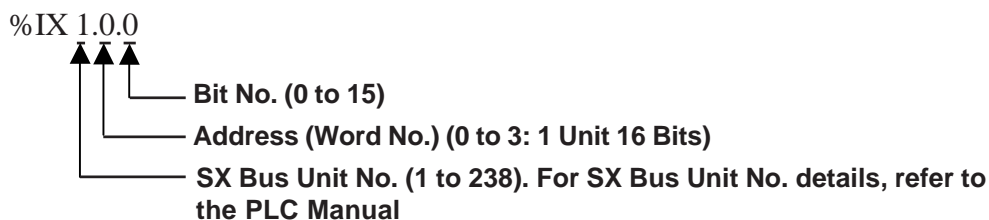

• WordDesignation

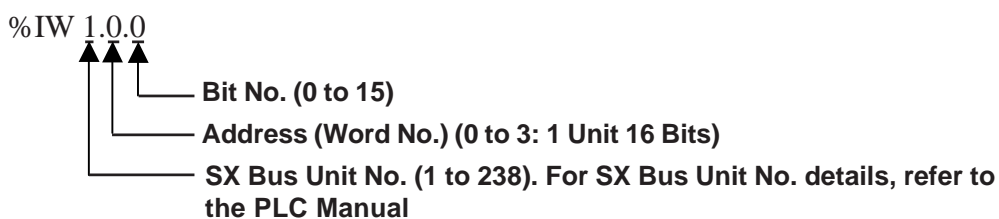

*2 Standard/Retain/System Memory Address Designation is as shown below.

- BitDesignation

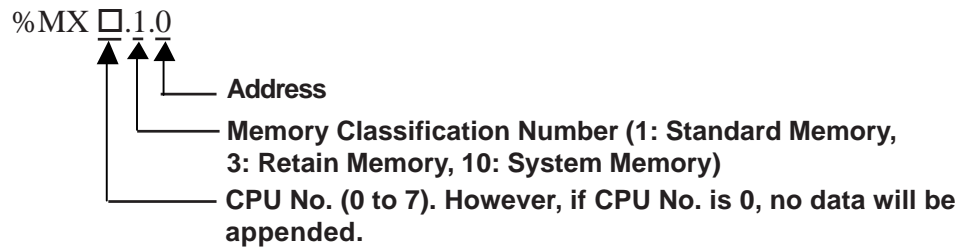

- WordDesignation

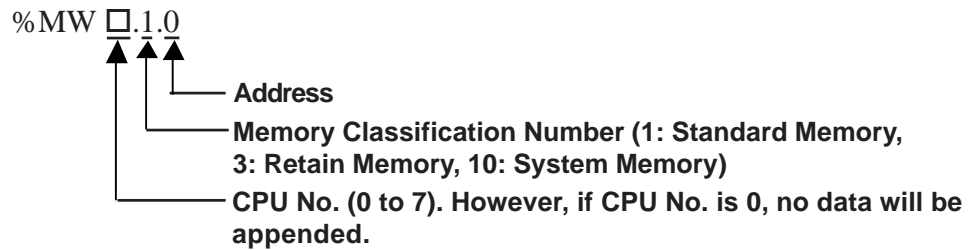

*3 Standard GP internal memory is allocated 65535 words. As a result, be sure any tags, etc. used do not span consecutive addresses. Failure to do so may cause a "Host Communication Error (02:44)" message to display.

*4 Standard and Retain memory sizes can be changed. However, the total memory size is fixed. (For details, refer to your PLC Manual). The screen editor's default setting assumes the input address range is set for the maximum.



• Standard/Retain/System Memory Address Word Designation

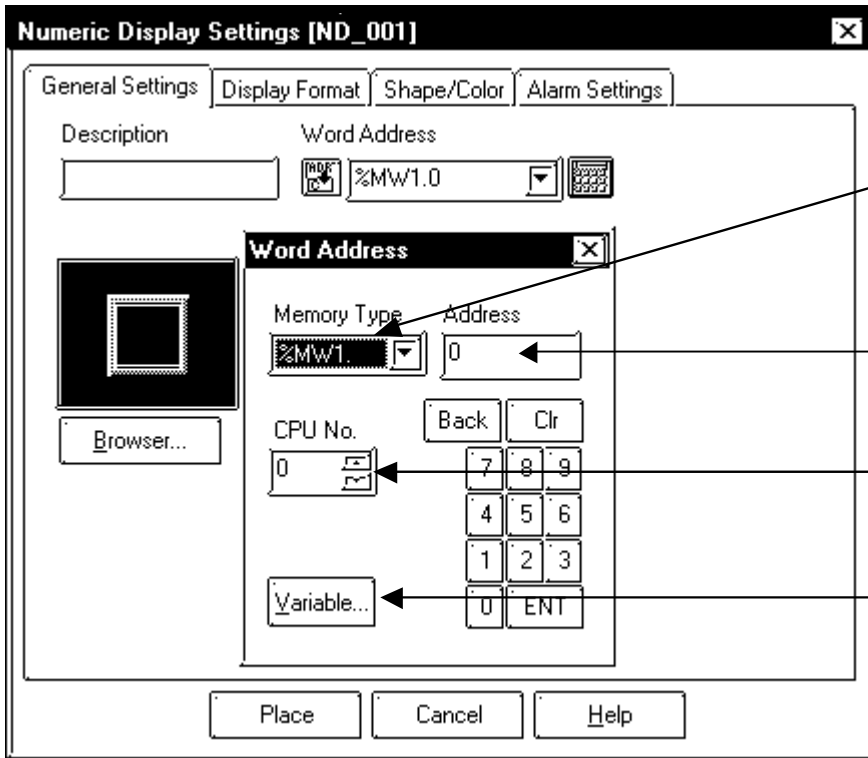

Memory Type (%MW1, %MW3, %MW10)

Address

CPU No. (0 to 4)

PLC Variable Designation: It is necessary to import variables when designating PLC variables. For details, refer to 5-6(4) Special Settings

• Input/Output Memory Word Designation

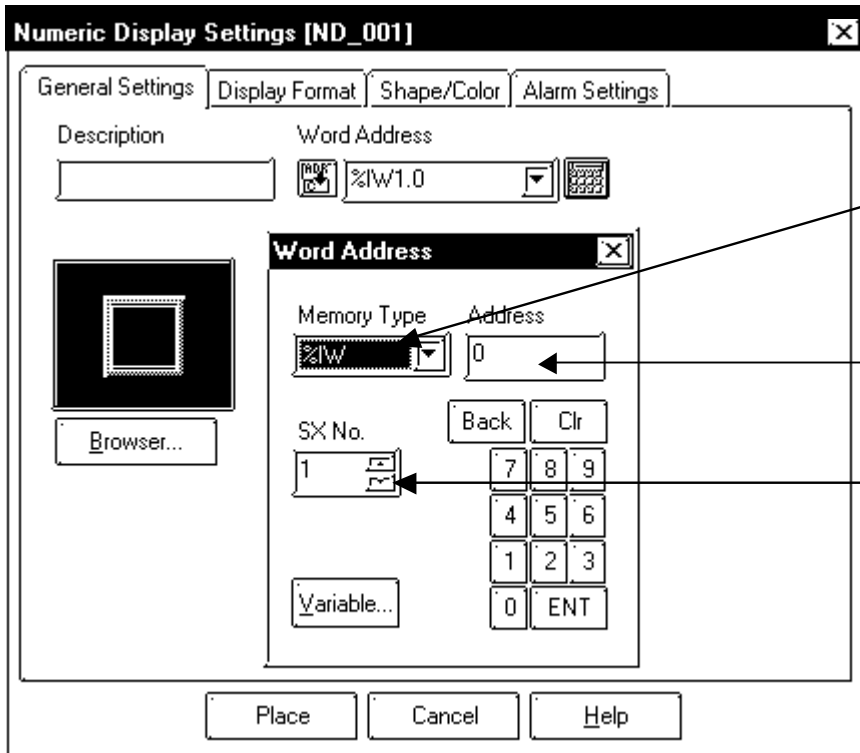

Memory Type (%IW, %QW)

Address (Word No.)

SX No. (1 to 238)

• Standard/Retain/System Memory Address Bit Designation

Memory Type
(%MX1, %MX3, %MX10)

Address

Bit No. (0 to 15)

CPU No. (0 to 4)

• Input/Output Memory Bit Designation

Memory Type
(%IX, %QX)

Address (Word No.)

Bit No. (0 to 15)

SX Unit No. (1 to 238)



The device address range available will vary depending on the type of CPU used. Be sure to check the PLC manual for your unit prior to actual use.



- **When using PLC direct address designation, be sure the range used is the AT range designated in the ladder software program. Also, Pro-face recommends that the PLC variables used on the GP be the designated AT variables.**

For detailed AT range designations and set up method information, please refer to the Fuji Electric Corporation's MICREX-SX Series D300Win<Reference Manual> User Manual.

When using variables not designated by AT and changing the variables or ladder program, they must be reconverted and re-imported, then sent again via screen transfer to the GP.

- **When using the System Area or Read Area, be sure the range used is the AT range designated.**
- **When a high-performance CPU is used to access the system area, be sure to use addresses starting from %MW2048.**
- **Only Global PLC variables can be set using the Editor software. Local variables cannot be set.**
- **When using Pro-Server, symbols must be designated and screens must be created for the devices to be accessed, then transferred to Pro-Server using Pro-Server's Import Symbol feature. For details, please refer to the Pro-Server Operation manual.**

MICREX-SX Series Variable Conversion Program

The variable conversion program "cv_micrexsx.exe" creates a conversion file that is used to import ladder program variables created with Fuji Electric Corporation's MICREX-SX Series Ladder Software "D300win" into screen creation software. This variable conversion program has the following features.

- 1) Using a file saved via D300win, reads out variable information and outputs the following files:
 - a) A symbol file (*.LBE) that is used by GP-PRO/PBIII's Symbol Editor for importing symbols.
 - b) A variable file (*.VRF) that consists of conversion information (Tag settings, etc.) used by GP-PRO/PBIII to import variables.
- *Applicable ladder software: Fuji Electric Corporation's MICREX-SX Series Programming Support Tool D300Win Ver. 3.1*
- *Compatible OS types: Windows98/ Windows2000/ Windows ME/ Windows NT/Windows XP*

Basic Steps Prior to Using Variables

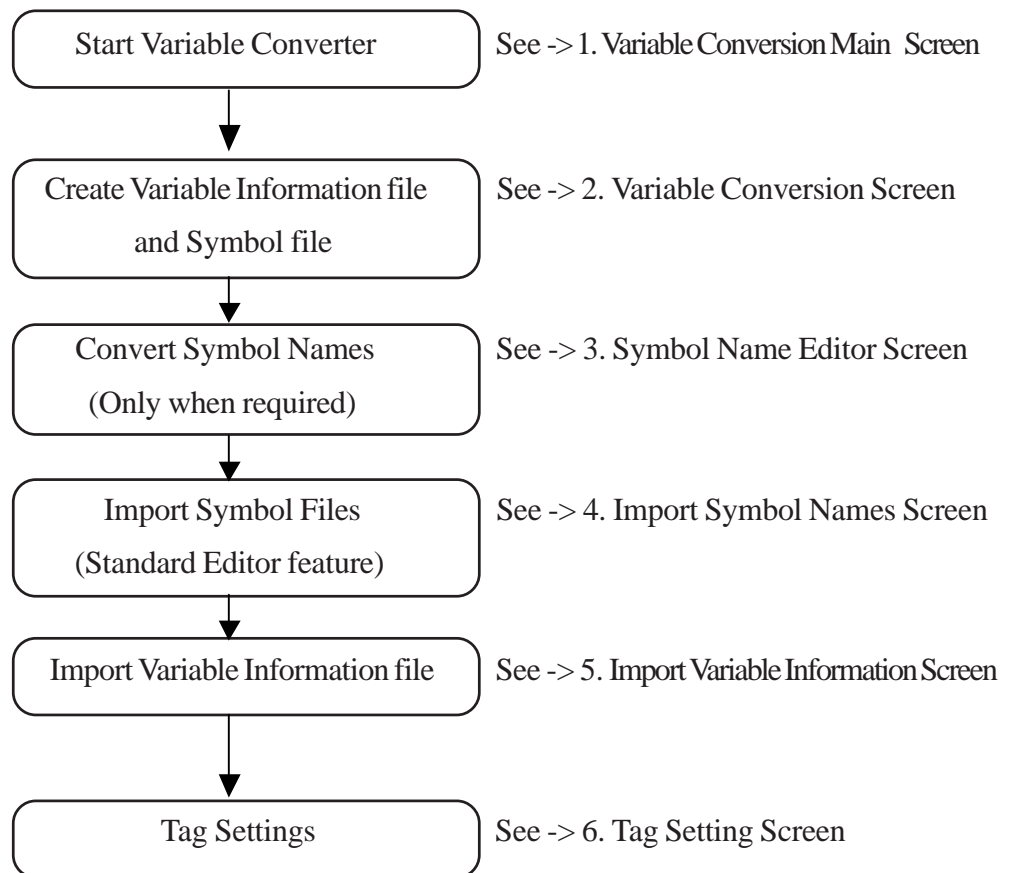

1. Variable Conversion Main Screen

Start up the variable conversion program cv_micrexx.exe. Immediately after startup, the following Variable Conversion Main Screen will appear. The cv_micrexx.exe file is installed with the GP-PRO/PBIII C-Package. This program is installed when the default installation is performed and is contained in the following folder.

C:\Program Files\Pro-face\ProPBWin

Variable Conversion Main Menu

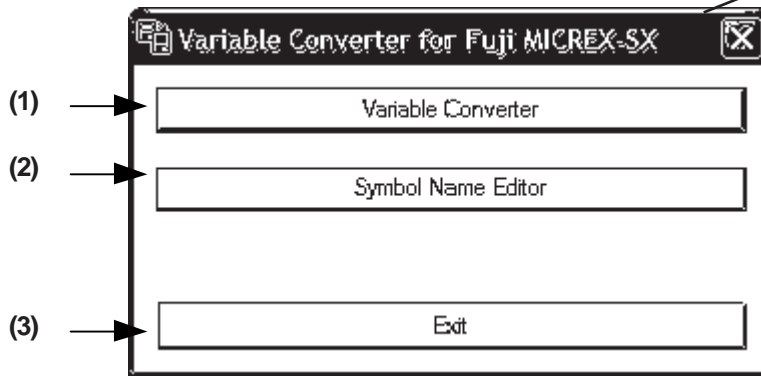

Right-clicking on this section calls up the "About" screen.

(1) Variable Converter

Displays the Variable Conversion screen. (See below)

(2) Symbol Name Editor

Displays the Symbols Name Editor screen. See -> File Update Check dialog box.

(3) Exit

Quits the conversion program.

2. Variable Conversion Screen

This screen is used to designate files created using the D300Win Ladder Logic software, and convert those variables.

Variable Conversion Main Menu

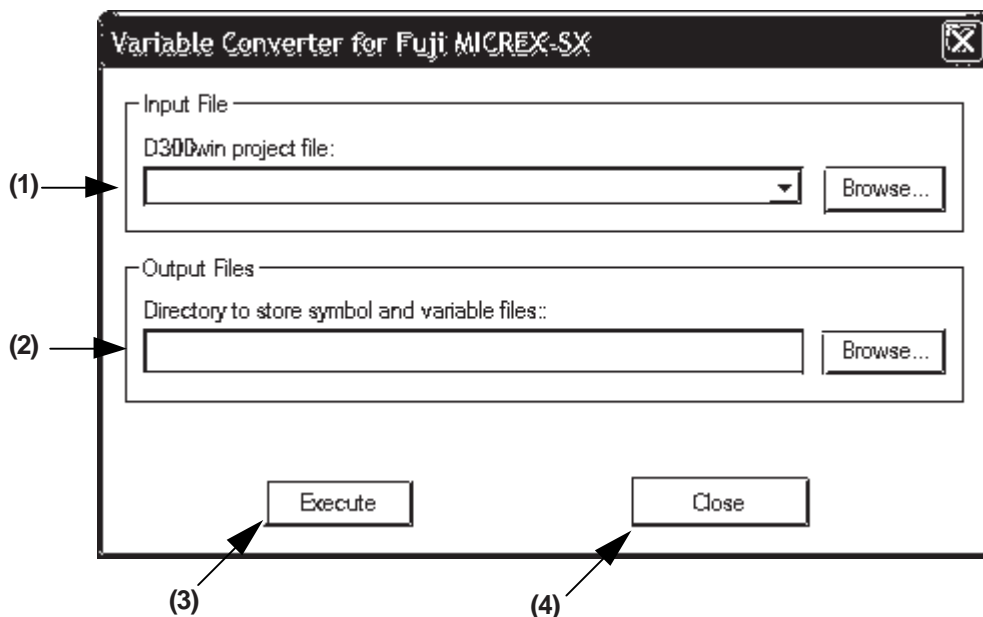

(1) D300win project file:

Used to select the desired D300win project file (*.mwt). The path and filename of any selected D300win project will remain in the combo-box menu, up to the 10 most recent projects. Simply selecting a previously run project will place its name in this filename entry line.

Also, once the path is selected, the program will automatically read the file extension ".mwt" and by default automatically insert that file in the directory path marked by "_VRF", which is used to save symbol/variable files.

(2) Directory to store symbol and variable files:

Designates the directory used for symbol and variable file output. Also, when the D300win project file is selected, the program will automatically read the file extension ".mwt" from the file path and by default automatically insert that file in the directory path marked by "_VRF".

The following file is output to the designated location. The filename is automatically created, based on the configuration name set in the ladder software.

- Symbol file (*.LBE)

Symbol file created after converting variables in GP-PRO/PBIII.

- Variable file (*.VRF)

Variable information file required by GP-PRO/PBIII.

(3) Execute

Performs the conversion processing. If a previously created output file exists, the following "File Update Confirmation Dialog Box" will appear.

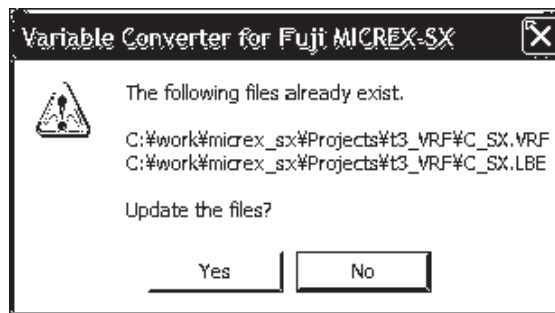
File Update Confirmation Dialog Box

After the conversion is completed, either the "No Change to Symbol Name" dialog box or the "Changed Symbol Name" dialog box will appear. For steps on converting variables to symbol names, refer to step 4. Import Symbol Names Screen.

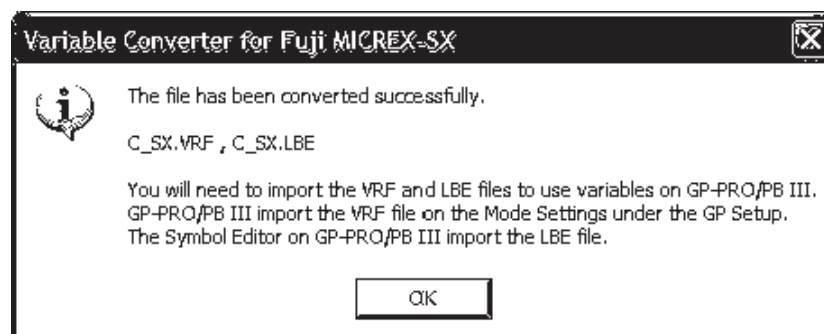
No Change to Symbol Name Dialog Box

Symbol Name Changed Dialog Box

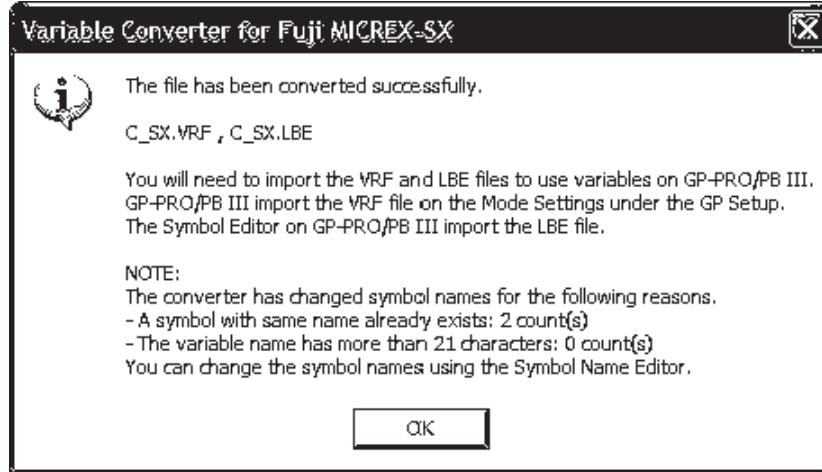

(4) Exit

Clicking this button completes all processing and returns to the Variable Conversion Main Menu.

◆ **Converting Variable Names to Symbol Names**

When converting D300win variable names(max. 30 char.) to GP-PRO/PBIII symbol names (max. 20 char.), some variable names may be allocated to the same name symbol. In this case, use the steps below to convert variable names to symbol names.

- (1) When variable names are 21 characters or longer, 20 characters are taken, starting from the left-most character.
- (2) Check if the variable name has been previously registered as a symbol name.
- (3) If it has not been previously registered, that variable name is used as the symbol name.
- (4) If it has been previously registered as a symbol name, apply symbol names using the following steps, starting from the smallest value and continuing to the largest value, until an unregistered symbol name is found. If the largest value is reached and a symbol name has not been found, remove the variable's right-most character and repeat the same process from step (2).

Variable Name to Symbol Name Conversion Table

No. of Var. Char.	Continuous. No. of Char. (Min.)	Continuous. No. of Char. (Max.)	Symbol Name Type	Description
1 to 11	1	99999999		Same symbol name is 10000000 or more.
12	1	9999999	Var. Name " _ " Contin. No.	Same symbol name is 1000000 or more.
13	1	999999		Same symbol name is 100000 or more.
14	1	99999		Same symbol name is 10000 or more.
15	1	9999		Same symbol name is 1000 or more.
16	1	999		Same symbol name is 100 or more.
17	1	99		Same symbol name is 10 or more.
18	1	9		Same symbol name is 2 or more.
19	None	None		Var. Name
20	None	None	Var. Name	No other symbol names are same.

When a variable name is 30 characters long, i.e. "ABCDEFGHJKLMNOPQRSTUVWXYZ1234" and is to be converted to a symbol name, the following example table shows the conversion results. See -> 1. Variable Conversion Main Screen.

Conversion Results of Conversion Table

No. of Char in Var. Name	Continuous. No. of Char. (Min.)	Continuous. No. of Char. (Max.)
20	ABCDEFGHIJKLMNOPQRST	ABCDEFGHIJKLMNOPQRST
19	ABCDEFGHIJKLMNQRST	ABCDEFGHIJKLMNQRST
18	ABCDEFGHIJKLMNQR_1	ABCDEFGHIJKLMNQR_9
17	ABCDEFGHIJKLMNOQ_1	ABCDEFGHIJKLMNOQ_99
16	ABCDEFGHIJKLMNO_1	ABCDEFGHIJKLMNO_999
15	ABCDEFGHIJKLMNO_1	ABCDEFGHIJKLMNO_9999
14	ABCDEFGHIJKLMN_1	ABCDEFGHIJKLMN_99999
13	ABCDEFGHIJKLM_1	ABCDEFGHIJKLM_999999
12	ABCDEFGHIJKL_1	ABCDEFGHIJKL_9999999
11	ABCDEFGHIJK_1	ABCDEFGHIJK_99999999
10	ABCDEFGHIJ_1	ABCDEFGHIJ_999999999
9	ABCDEFGHI_1	ABCDEFGHI_999999999
8	ABCDEFGH_1	ABCDEFGH_999999999
7	ABCDEFG_1	ABCDEFG_999999999
6	ABCDEF_1	ABCDEF_999999999
5	ABCDE_1	ABCDE_999999999
4	ABCD_1	ABCD_999999999
3	ABC_1	ABC_999999999
2	AB_1	AB_999999999
1	A_1	A_999999999

3. Symbol Name Editor Screen

When the "Symbol Name Editor" is selected, the following screen will appear. This screen is allows you to edit the symbol name information of imported symbols.

Symbol Name Editor Main Screen

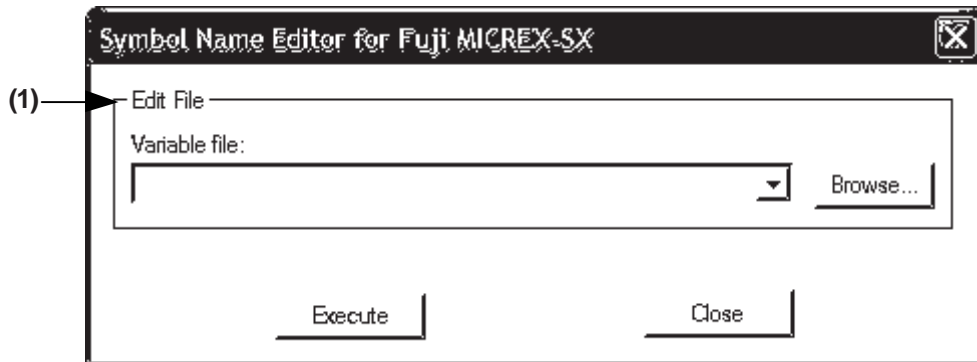

(1) Edit File

Selects the output file (*.VRF) created by [Variable Conversion]. The path of any selected variable file will remain in the combo-box menu, up to the 10 most recent files and can be easily selected.

(2) Execute

Displays the variable list screen to perform the symbol name conversion. (See below)

(3) Close

Quits the symbol conversion processing and returns to the Variable Conversion Main Menu.

◆ List of Variables Screen

After designating the file name and clicking [Execute], the following screen will appear.

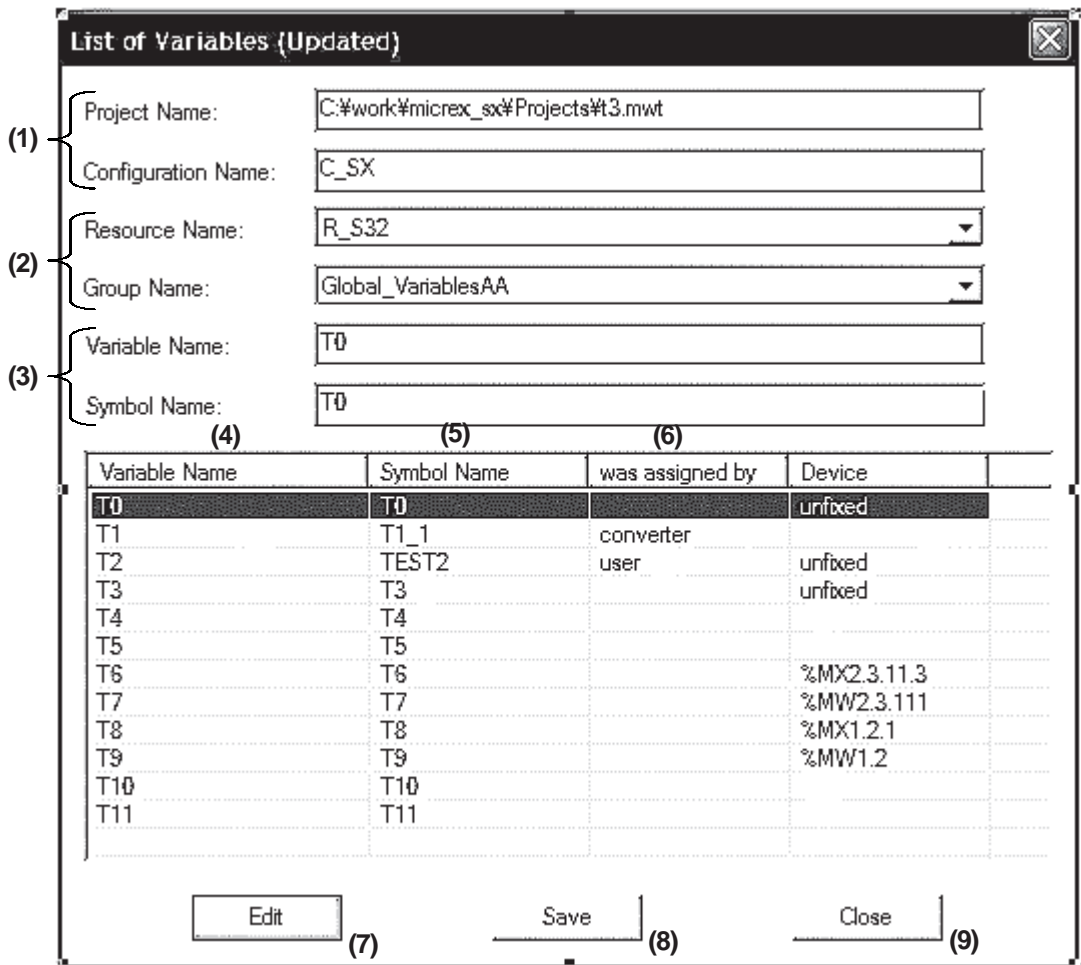

(1) Project Name, Configuration Name

Displays the selected variable file's D300win's project and configuration names. The configuration name's default is "C_SX", and can be changed via the ladder software.

(2) Resource Name, Group Name

When the Resource or Group names are selected, their registered variable and symbol names will appear.

Resource Name: Resource names registered to the D300win project.

Group Name: Group names registered to the D300win project.

(3) Variable Name, Symbol Name

Displays the selected variable and symbol names.

(4) Variable Name

Displays the variable name(s) set in the PLC ladder program.

(5) Symbol Name

Displays the symbol names registered in the GP Symbol Editor.

(6) was assigned by

Indicates the method used to set the symbol name.

a) [Blank]

Indicates same variable and symbol names were entered using either the variable conversion program or manually.

b) converter

Indicates the conversion program changed the variable name to a different symbol name.

c) user

Indicates the variable name was manually changed to a different symbol name.

(7) Edit

Clicking on the [Edit] button causes the selected variable's [Symbol Name Editor] edit screen to appear. (See -> 3. Symbol Name Editor Screen)

You can also double-click on the variable name's row to call up the edit screen.

(8) Save

Saves the edited symbol names to the variable and symbol files.

(9) Close

Returns to the Symbol Name Editor screen. (See -> 3. Symbol Name Editor Screen) However, if this is clicked after symbols are edited but before the changes have been saved, the following [Variable File Save Confirmation Screen] will appear.

Variable File Save Confirmation Screen

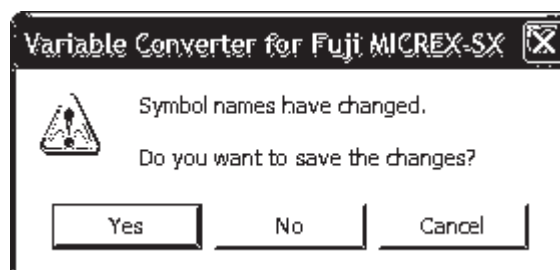

◆ Symbol Name Editor Screen

The Symbol Name Editor Screen is as follows. All data in this screen, except for the symbol name, is view-only and cannot be edited.

Symbol Name Editor Screen

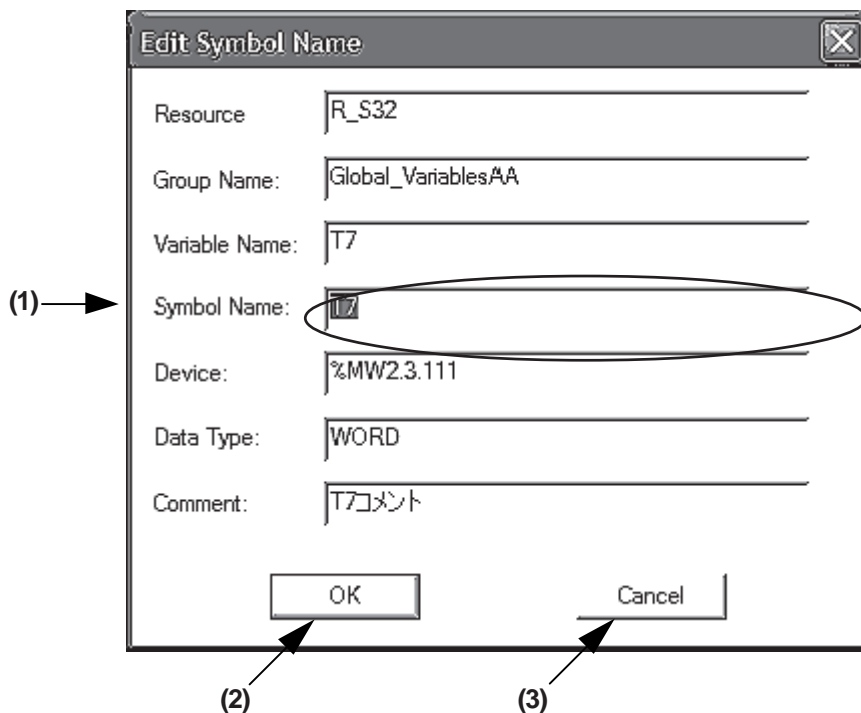

(1) Symbol Name

Symbol name can be edited.

(2) OK

After editing the symbol name, returns to the [List of Variables].

(3) Cancel

Closes this screen and returns to the previous [List of Variables] screen, without changing symbol name data.

4. Import Symbol Names Screen

This Editor feature will import symbol files.

Symbol Editor



Importing Symbol files

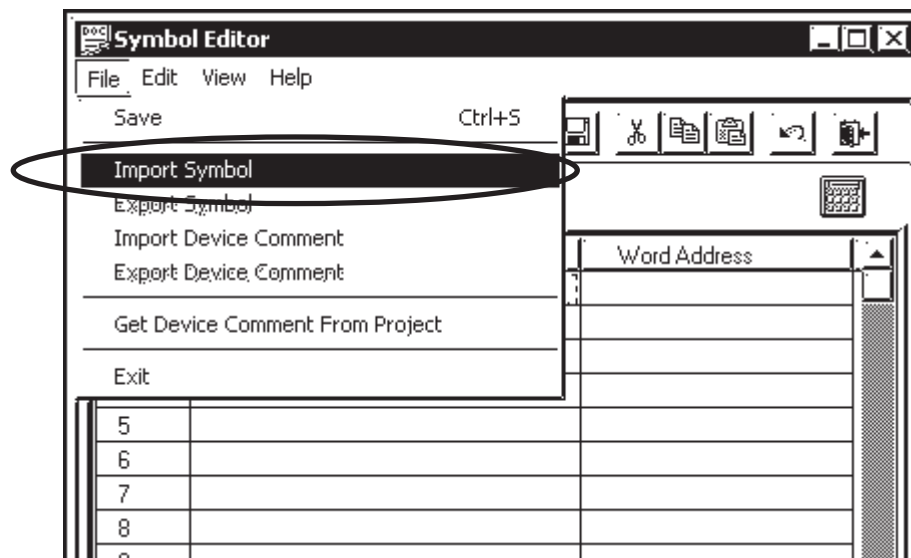

5. Import Variable Information Screen

The "Import Variable" feature reads the file created by the variable conversion program. After this information is read, variable name information can be seen when setting up Tags.

Mode Settings Screen

Click the [GP Setup] screen's [Mode Settings] tab. Then, click the [Variable Import] button to call up the [Variable Import] screen.

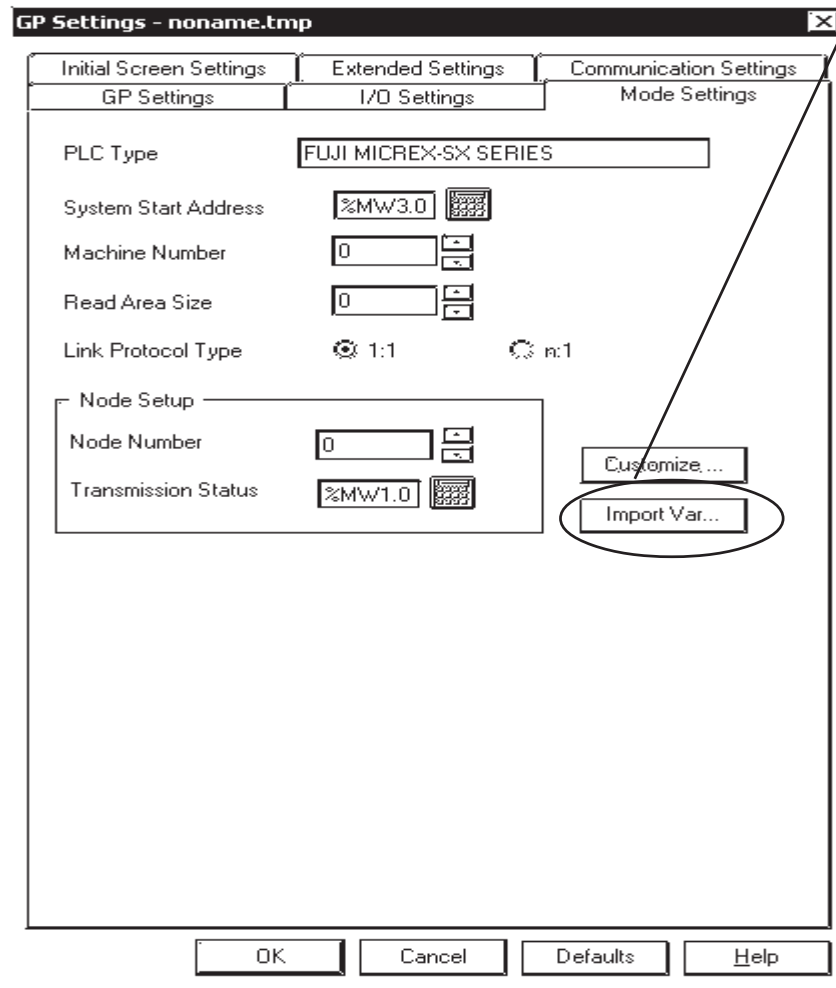

After clicking the [Variable Import] button, the following [Variable Import] screen appears. Here is where the variable file (*.VRF) is designated. Clicking [OK] changes to the [Project Confirmation] screen. (See -> Project Confirmation Screen)

Variable Import Screen

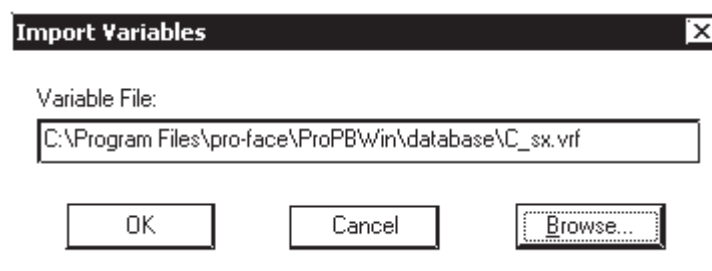

After clicking the [GP Setup] screen's [Variable Import] button, the following [Project Confirmation] screen appears. Clicking [OK] imports the variable file, and returns to the [Mode Settings] screen. Pressing [Cancel] returns to the [Mode Settings] screen and does not import the variables. (See -> Mode Settings Screen)

Project Confirmation Screen

6. Tag Setting Screen

To enter Tag settings, simply click on the keypad to call up the following screen. Next, click on the keypad's [Variable (V)] button to call up the [Variable Designation Screen].

If [Variable Import] has not been performed, the [Variable (V)] button will be disabled (gray).

Keypad Screen

If [Variable Import] has been performed

If [Variable Import] has NOT been performed

After the [Variable (V)] button is pressed, the following screen will appear and variables can be selected. After selecting the Resource and Group names, select the Variable name.

Variable Designation Screen

Choose Variable

Resource: R_S117

Group Name: GV

Variable Name: NewVar2

Symbol Name: NewVar2

Device: %MW3.20

Data Type: INT

Comment:

OK Cancel

Imported variable information is displayed here.

Information related to the selected variables is displayed here.

In the Variable Designation screen, imported variables can be selected.

Variable Designation Screen

Choose Variable

Resource: R_S117

Group Name: GV

Variable Name: A0

Symbol Name:

Device:

Data Type:

Comment:

OK Cancel

Imported variable information is displayed in a list, allowing you to select the desired variable. (Variable information is sorted) Character search feature is included.



- **Pro-face recommends using AT designation (Address designation) when setting up the communication area to communicate with a GP Series unit. If the variables are not AT designated, they will be automatically allocated by the ladder software.**
- **Only Global PLC variables can be set using the Editor software. Local variables cannot be set.**
- **After using the Screen Editor to import symbols, do not use the Symbol Editor to update addresses used by variables. If these addresses are updated, it will create a difference between the address settings used in the ladder software, which could in turn lead to a unit operation error. Also, if ladder software variables are updated, they must be reimported to update the variable information.**

4

Environment Setup

The following tables list Digital's recommended PLC and GP communication settings.

■ **MICREX-F Series** (using PC I/F module FFU120B)

GP Setup		FFU120B Setup	
Baud Rate	19200 bps	Baud Rate	19200 bps
Data Length	7 bit	Data Bit	7 bit
Stop Bit	2 bit	Stop Bit	2 bit
Parity Bit	Even	Parity Bit	Even
Data Flow Control	ER Control	Transfer Condition	None
Communication Format (RS-232C)	RS-232C	MODE Switch (RS-232C)	1
Communication Format (RS-422)	4-wire type	MODE Switch (RS-422)	3
-----		Char. structure Switch	8 (INIT) is Off
-----		RS-485 Station # setup Switch (Only for RS-485)	0
-----		DCE/DTE Mode	DCE Mode
-----		Transfer Process Mode	No Process Setting
-----		CTS/RTS Control	Normally ON
-----		DSR/DTR Control	Normally ON
-----		PK Access	Allowed
-----		Transfer Code	JIS
-----		Code Conversion	Used
-----		Start Code	STX
-----		End Code	ETX
-----		Start code 1,2	0
-----		End Code 1,2	0
-----		BCC	None
Unit No.	0 (fixed)	-----	



Setup this data in *File Definition*. Communication is not possible when using a Link I/F switch.

■ **MICREX-F Series** (using General Interface Module NC1L-RS2)

GP Setup		NC1L-RS2 Setup	
Baud Rate	19200 bps	Baud Rate	19200 bps
Data Length	8 bit	Data Bit	8 bit
Stop Bit	1 bit	Stop Bit	1 bit
Parity Bit	Even	Parity Bit	Even
Data Flow Control	ER Control	Transfer Condition	None
Communication Format (RS-232C)	RS-232C	MODE Switch (RS-232C)	1
-----		Char. Structure Switch	8 (INIT) is Off (FILE)
-----		DCE/DTE Mode	DCE Mode
-----		Transfer Process	No Process
-----		Mode	Setting
-----		CTS/RTS Control	Normally ON
-----		DSR/DTR Control	Normally ON
-----		PK Access	Allowed
-----		Transfer Codes	JIS
-----		Code Conversion	Used
-----		Start Code	STX
-----		End Code	ETX
-----		Start code 1,2	0
-----		End Code 1,2	0
-----		BCC	None
Unit No.	0 (fixed)	-----	



Setup this data in *File Definition*. Communication is not possible when using a Link I/F switch.

■ **MICREX-F Series** (using PC I/F capsule FFK120A-C10)

GP Setup		FFK120A-C10 Setup	
Baud Rate	19200 bps	Baud Rate	19200 bps
Data Length	7 bit	Data Bit	7 bit
Stop Bit	2 bit	Stop Bit	2 bit
Parity Bit	Even	Parity Bit	Even
Data Flow Control	ER Control	Transfer Condition	None
Communication Format (RS-232C)	RS-232C	MODE Switch (RS-232C)	1
Communication Format (RS-422)	4-wire type	MODE Switch (RS-422)	3
-----		Char. structure Switch	8 (INIT) is Off (FILE)
-----		RS-485 Station # setup Switch (Only for RS-485)	0
-----		DCE/DTE Mode	DCE Mode
-----		Transfer Process	No Process
-----		Mode	Setting
-----		CTS/RTS Control	Normally ON
-----		DSR/DTR Control	Normally ON
-----		PK Access	Allowed
-----		Transfer Code	JIS
-----		Code Conversion	Used
-----		Start Code	STX
-----		End Code	ETX
-----		Start code 1,2	0
-----		End Code 1,2	0
-----		BCC	None
Unit No.	0 (fixed)	-----	



Setup this data in *File Definition*. Communication is not possible when using a Link I/F switch.

■ **MICREX-F Series** (using PC I/F capsule FFK100A-C10)

GP Setup		FFK100A-C10 Setup	
Baud Rate	9600 bps	Baud Rate	9600 bps
Data Length	7 bit	Data Bit	7 bit
Stop Bit	2 bit	Stop Bit	2 bit
Parity Bit	Even	Parity Bit	Even
Data Flow Control	ER Control	Transfer Condition	None
Communication Format (RS-232C)	RS-232C		
-----		Char. Structure Switch	8 (INIT) is Off (FILE)
-----		DCE/DTE Mode	DCE Mode
-----		Transfer Process	No Process
-----		Mode	Setting
-----		CTS/RTS Control	Normally ON
-----		DSR/DTR Control	Normally ON
-----		PK Access	Allowed
-----		Transfer Code	JIS
-----		Code Conversion	Used
-----		Start Code	STX
-----		End Code	ETX
-----		Start code 1,2	0
-----		End Code 1,2	0
-----		BCC	None
Unit No.	0 (fixed)	-----	



Setup this data in *File Definition*. Communication is not possible when using a Link I/F switch.

■ MICREX-F Series (FLT-ASFK)

GP Setup		Adapter Setup	
Baud Rate	19200 bps	Baud Rate	19200 bps
Data Length	8 bit	Data Length	8 bit
Stop Bit	1 bit	-----	
Parity Bit	Even	Parity Bit	Even
Data Flow Control	ER Control	Transfer Condition	None
Communication Format	RS-232C	-----	
Unit No.	0	-----	
-----		MODE	LOADER



Note:

This is set via the adaptor's dipswitch. There is no need to set this via the initial file.

■ MICREX-SX Series

• CPU Direct Connection

GP Settings		PLC Settings	
Baud Rate	38400 bps (Fixed)	Baud Rate	38400 bps
Data Length	8 bits (Fixed)	Data Length	8 bits
Stop Bit	1 bit (Fixed)	Stop Bit	1 bit
Parity Bit	Even (Fixed)	Parity	Even
Data Flow Control	ER (Fixed)	_____	_____
Communication Format (When using RS-232C)	RS-232C	_____	_____
Communication Format (When using RS-422)	4-wire	_____	_____
Communication Format (When using RS-422)	2-wire	_____	_____
Unit No.	0 (Fixed)	_____	_____

• When Using the Communication Module

GP Settings		PLC Settings	
Baud rate	38400 bps (Fixed)	_____	_____
Data Length	8 bits (Fixed)	_____	_____
Stop Bit	1 bit (Fixed)	_____	_____
Parity Bit	Even (Fixed)	_____	_____
Data Flow Control	ER (Fixed)	_____	_____
Communication Format (When using RS-232C)	RS-232C	Mode Setting Switch	1 or 3
Communication Format (When using RS-422)	4-wire	Mode Setting Switch	2 or 3
Communication Format (When using RS-422)	2-wire	Mode Setting Switch	2 or 3
Unit No.	0 (Fixed)	_____	_____

■ FLEX-PC Series (When using the Link I/F)

GP Settings		Communication Unit, Interface Module Settings	
Baud rate	19200 bps	Baud rate	19200 bps
Data Length	7 bit	Data Length	7 bit
Stop Bit	1 bit	Stop Bit	1 bit
Parity Bit	Even	Parity Bit	Even
Data Flow Control	ER	Send Status	DTRon/CTSon
Communication Format (When using RS-232C)	RS-232C	Mode Switch (When using RS-232C)	1
Communication Format (When using RS-422)	4-wire	Mode Switch (When using RS-422)	3
Unit No.	1 (Fixed)	Station No.	1

■ FLEX-PC Series (CPU Direct Connection)

GP Settings		PLC Settings	
Baud Rate	19200 bps (Fixed)	_____	_____
Data Length	8 bit (Fixed)	_____	_____
Stop Bit	1 bit (Fixed)	_____	_____
Parity Bit	Odd (Fixed)	_____	_____
Data Flow Control	ER (Fixed)	_____	_____
Communication Format	4-wire (Fixed)	_____	_____
Unit No.	1 (Fixed)	_____	_____