

Device/PLC Connection Manuals



About the Device/PLC Connection Manuals

Prior to reading these manuals and setting up your device, be sure to read the "Important: Prior to reading the Device/PLC Connection manual" information. Also, be sure to download the "Preface for Trademark Rights, List of Units Supported, How to Read Manuals and Documentation Conventions" PDF file. Furthermore, be sure to keep all manual-related data in a safe, easy-to-find location.



2.23 FATEK

2.23.1 System Structure



The following describes the system structure for connecting to Fatek's Facon PLCs.

Reference The Cable Diagrams mentioned in the following tables are listed in the section titled "2.23.2 Cable Diagrams".

■ Facon FB Series (using CPU Direct Connection)

CPU	Cable Diagram	Cables	GP/GLC
			
FB _E -20MC FB _E -28MC FB _E -40MC	RS-232C (Cable Diagram 1)		GP/GLC Series
	RS-232C (Cable Diagram 2)	FATEK's FB-232PO-9F	
	RS-422 2-wire (Cable Diagram 3)		

■ Facon FB Series (Link I/F)

CPU	Link I/F	Cable Diagram	GP/GLC
			
FB _E -20MC FB _E -28MC FB _E -40MC	RS-232C(Port 0) on FB-DT BR	RS-232C (Cable Diagram 4)	GP/GLC Series
	RS-232C(Port 1) on FB-DT BR ^{*1}	RS-232C (Cable Diagram 5)	
	RS-485(Port 2) on FB-DT BR	RS-422 2-Wire (Cable Diagram 6)	

*1 9-Pin D-SUB Port.

2.23.2 Cable Diagrams

The cable diagrams shown below and the cable diagrams recommended by FATEK may differ, however, regardless of these differences, using Digital's recommended diagrams will not cause any operation problems.

Cable Diagram 1 (RS-232C)



- **Connect the shielded cable's FG line to the GP.**
- **When wiring your communication cable, be sure to connect the GP and PLC SG wires.**
- **Use a cable of length less than 15m.**

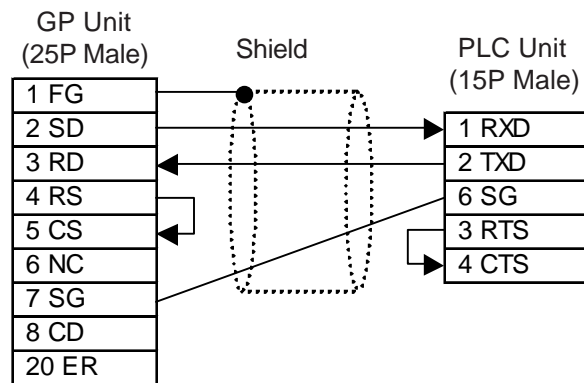

Cable Diagram 2 (RS-232C)

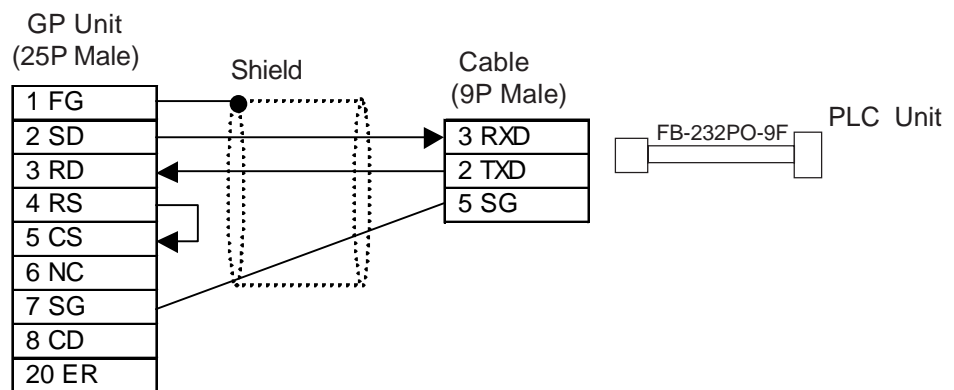

Cable Diagram 3 (RS-422 2-wire)



- **Connect the shielded cable's FG line to the PLC.**
- **The maximum cable length allowed is 600m.**

<When using Digital's RS-422 connector terminal adapter GP070-CN10-O>

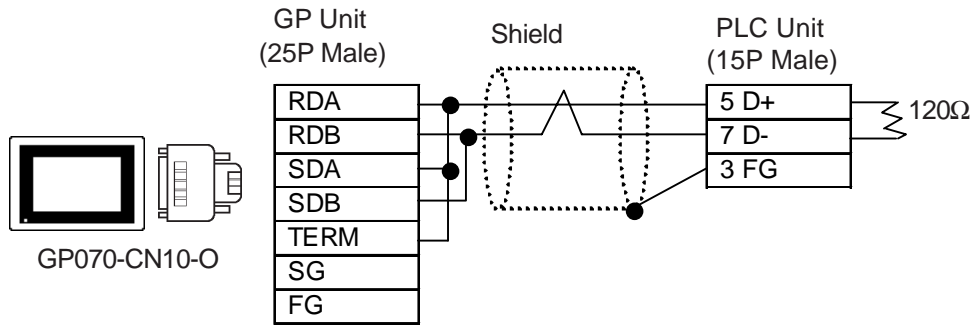

<When making your own cable>

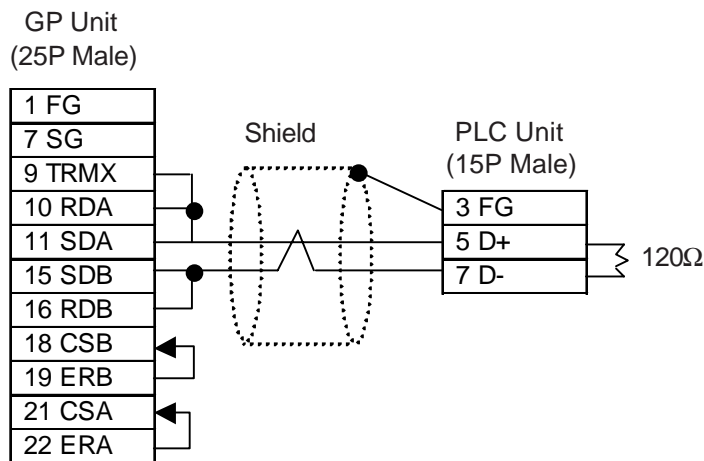

Cable Diagram 4 (RS-232C)

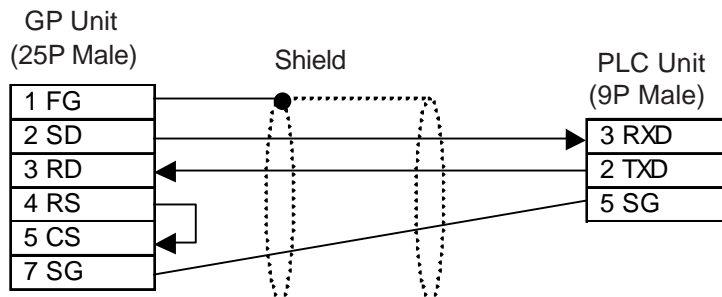

Cable Diagram 5 (RS-232C)

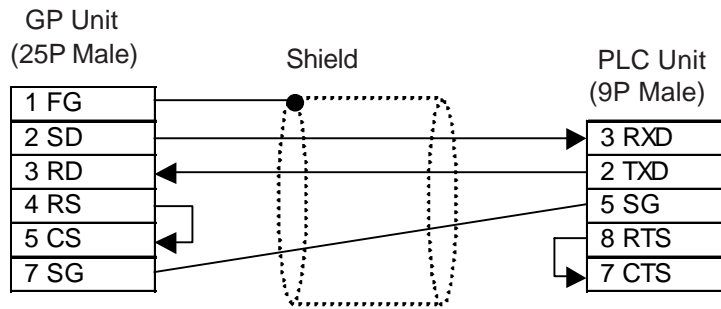

Cable Diagram 6 (RS-422 2-wire)



- **Connect the shielded cable's FG line to the PLC.**
- **The maximum cable length allowed is 600m.**

<When using Digital's RS-422 connector terminal adapter GP070-CN10-O>

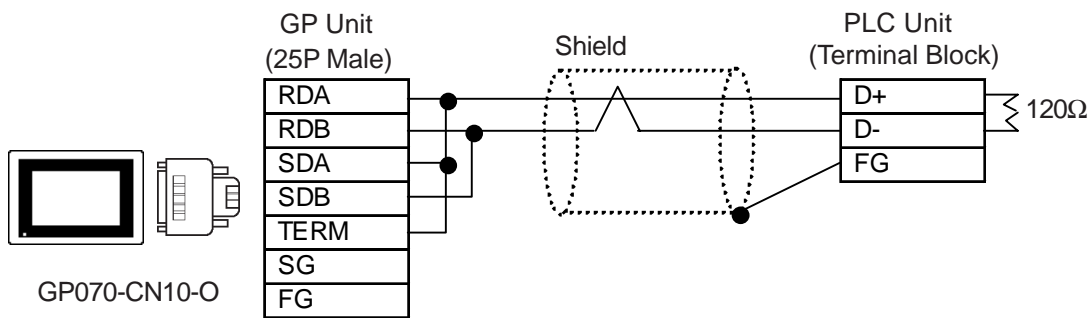

<When making your own cable>

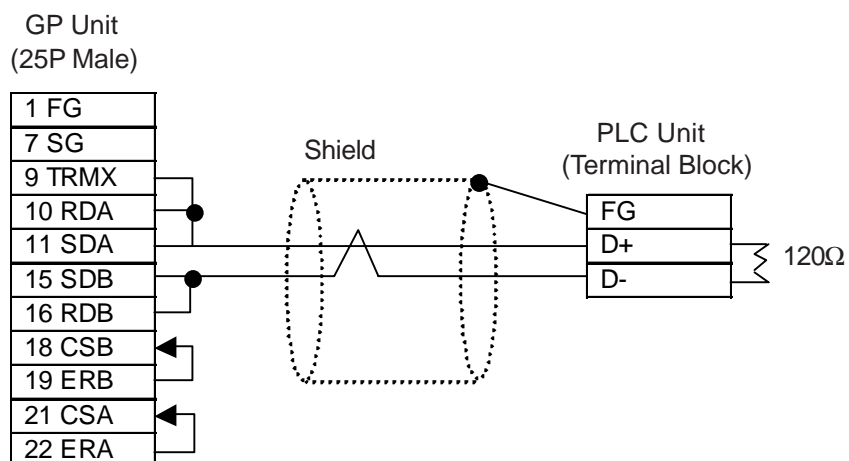

2.23.3 Supported Devices

The following describes the range of devices supported by the GP.

■ Facon FB Series

Setup System Area here.

Device	Bit Address	Word Address	Note
Input Relay	X0000 ~ X0255	WX0000 ~ WX0240	÷ 16
Output Relay	Y0000 ~ Y0255	WY0000 ~ WY0240	÷ 16
S Relay	S0000 ~ S0999	WS0000 ~ WS0976	÷ 16
Auxiliary Relay	M0000 ~ M2001	WM0000 ~ WM1984	÷ 16
Timer (contact)	T0000 ~ T0255	———	
Counter (contact)	C0000 ~ C0255	———	
Timer (current)	———	TMR0000 ~ TMR0255	
Counter (current)	———	CTR0000 ~ CTR0199	
Hi Speed Counter	———	HC0200 ~ HC0255	^{*2}
Data Register ^{*1}	———	HR0000 ~ HR8071	Bit 15 ^{*3}
Data Register ^{*1}	R0000000 ~ R0807115	R00000 ~ R08071	^{*3}
Data Register	D0000000 ~ D0307115	D00000 ~ D03071	
Special Relay	SM1912 ~ SM2001	WSM1912 ~ WSM1976	
Input Register	———	IR3840 ~ IR3903	Bit 15
Output Register	———	OR3904 ~ OR3967	Bit 15
HSC Register	———	HSC4096 ~ HSC4127	Bit 15
Calendar Register	———	RTC4128 ~ RTC4135	Bit 15
Special Register	———	SR4136 ~ SR4167	Bit 15
Read Only Register	———	ROR5000 ~ ROR8071	Bit 15 ^{*4}

L/H

**1 Within the PLC, data registers HR and R constitute the same device. However, the method used to write bits to these devices vary as described below. Therefore, be sure to use the correct method depending on the system's specifications.*

(Continued ...)

- When performing a bit-designated write to an R device, one bit can be written at a time.
- When performing a bit-designated write to an HR device, the 15 bits other than the designated bit will all be set to OFF (0).

*2 32-bit device.

*3 Word addresses HR5000 to HR8071 and R05000 to R08071 are read-only. While writing data to these addresses will not cause an error, the data will not be recorded in the PLC's memory.

*4 Read-only device. While writing data to these devices will not cause an error, the data will not be recorded in the PLC's memory.



Note: Device address range and write enable/disable features vary depending on the CPU. For details, refer to the corresponding PLC manual.

2.23.4 Environment Setup

The following table lists Digital's recommended PLC and GP communication settings.

■ Facon FB Series

GP Settings		Controller Settings	
Baud rate (bps)	9600bps	Baud rate ^{*1}	9600bps
Data length	7bit	Data bit ^{*1}	7bit
Stop bit	1bit	Stop Bit ^{*1}	1bit
Parity Bit	Even	Parity ^{*1}	Even
Communication Format when using RS-232C	RS-232C	_____	_____
Communication Format when using RS-485	2-wire type	_____	_____
Unit No.	1	Station Number	1
_____	_____	DSWBIT 1	OFF
_____	_____	DSWBIT 1	OFF

**1 For Port 0, the following parameters are fixed:*

Baud rate: 9600bps, Data bit: 7bit, Stop bit: 1bit, Parity: Even