

Device/PLC Connection Manuals



About the Device/PLC Connection Manuals

Prior to reading these manuals and setting up your device, be sure to read the "Important: Prior to reading the Device/PLC Connection manual" information. Also, be sure to download the "Preface for Trademark Rights, List of Units Supported, How to Read Manuals and Documentation Conventions" PDF file. Furthermore, be sure to keep all manual-related data in a safe, easy-to-find location.

2.14 Fanuc Motion Controller

2.14.1 System Structure



The following describes the system structure for connecting the GP to Fanuc Motion Controller PLCs.

Reference The Cable Diagrams mentioned in the following tables are listed in the section titled "2.14.2 Cable Diagrams".



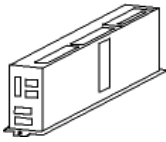

Be sure to inform the Fanuc Corporation clearly that the system will be connected with GP series unit(s).

■ FANUC Power Mate Series

CPU	Cable Diagram	GP
		
Power Mate -MODEL D	RS-422 (Cable Diagram 1)	GP Series

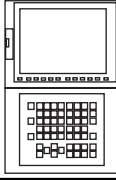
■ FANUC Series

CPU	Link I/F	Cable Diagram	Cables	Target Machine
				
16-MC ^{*1}	Link I/F on CPU ^{*2}	RS-232C (Cable Diagram 2)	GP410-IS00-O(5m)	GP/GLC Series ST401
16-Model C 18-Model C 16i-Model A 16i-Model B 18i-Model A 18i-Model B 21i-Model A 21i-Model B	Link I/F on CPU ^{*3}	RS-232C (Cable Diagram 3)	_____	GP/GLC Series ST401

**1 When connecting to a 16-MC, Fanuc's converting cable A02B-0120-C19 is needed to connect a D-Sub connector (20pins) and a D-Sub connector (25pins).*

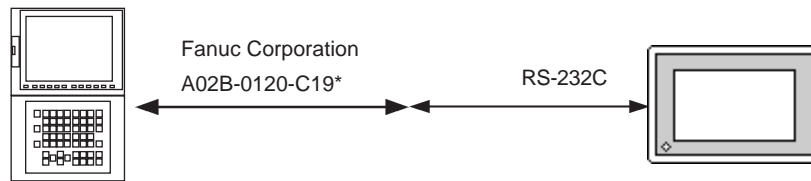

**2 The 16-MC unit can be connected only to serial port 2 (JD5B). It cannot be connected to serial port 1 (JD5A).*

**3 The 16-Model C can only use serial port 2 (JD5B). All others (18-Model C, 16i-Model A, 16i-Model B, 18i-Model A, 18i-Model B, 21i-Model A, 21i-Model B) must use the RS-232C serial port 2 (JD36B Port).*



2.14.2 Cable Diagrams

The cable diagrams illustrated below and the cable diagrams recommended by GE Fanuc Automation may differ, however, using these cables for your PLC operations will not cause any problems.



- *Connect a Termination Unit to the Motion Controller's JD15. The Termination Unit, with a resistance of 100Ω is connected to the RD B and RD A points.*

Motion Controller
JD15

1 RD B  Termination Resistance
2 RD A  1/2W100Ω

- *Ground your Motion Controller Unit's FG terminal. For details, refer to the Motion Controller manual.*
- *Ground the Shield to the Cable Clamp.*
- *If a communications cable is used, it must be connected to the SG (signal ground).*



- *When using RS-422 connection, check the cable length with Fanuc Motion Controller PLC's users manual.*
- *Depending on the usage environment, set the side used for the the shield line's FG connection (GP or PLC). When the connector hood is used for the FG, be sure the hood is made from a conductive material.*
- *With an RS-232C connection, be sure the cable length is 15m or less.*
- *When creating a communication cable, be sure the SG wire is connected.*

Cable Diagram 1 (RS-422)

GP/GLC Series Units

- When using Digital's RS-422 connector terminal adapter GP070-CN10-0

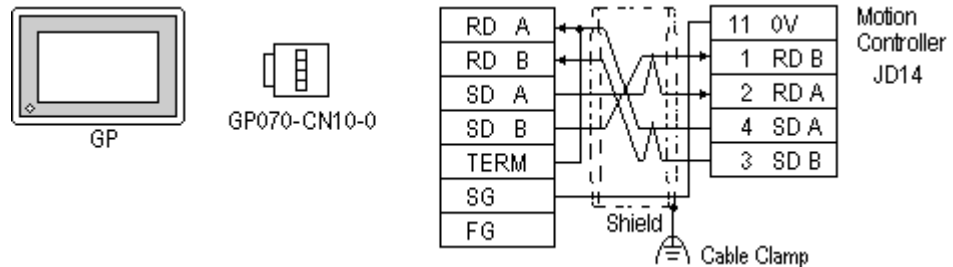

- When making your own cable connections

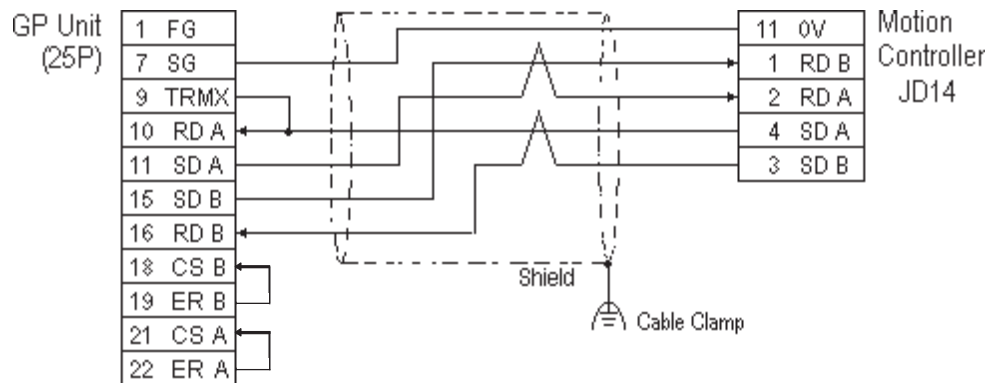

- **Recommended Cable:** Oki Densen's A66L-0001-0284#10P
- **Recommended Connector:** Honda Tsushin Kogyo's PCR-E20FS
- **Recommended Connector Case:** Honda Tsushin Kogyo's PCR-V20LA
- **When connecting the #9 and #10 pins in the GP Serial I/F, a termination resistance of 100Ω is added between RDA and RDB.**

ST400 Unit

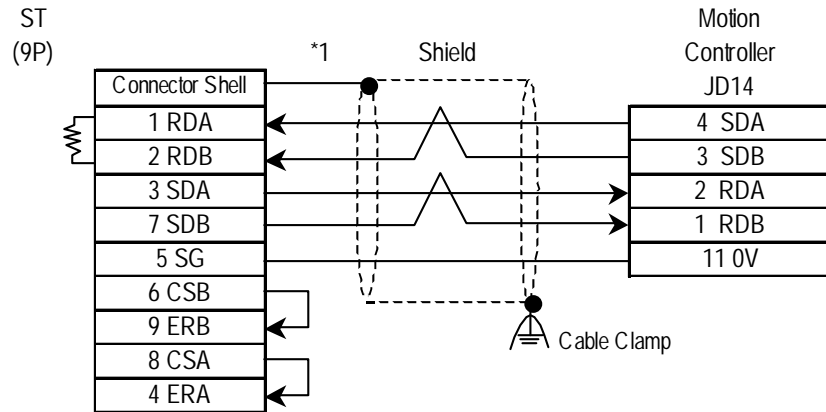

*1 Be sure to connect the shield to the Connector Shell. For information about FG connections, refer to page 1-2 "RS422 I/F (ST400)" section's Note, in the "Connecting a Device/PLC to the ST unit."



- Note:**
- Recommended Cable: Oki Densen's A66L-0001-0284#10P.
 - When connecting the GP/GLC via a RS-422 cable, refer to Fanuc Corporation's manual for cable length.

Cable Diagram 2 (RS-232C)

GP/GLC Series Units

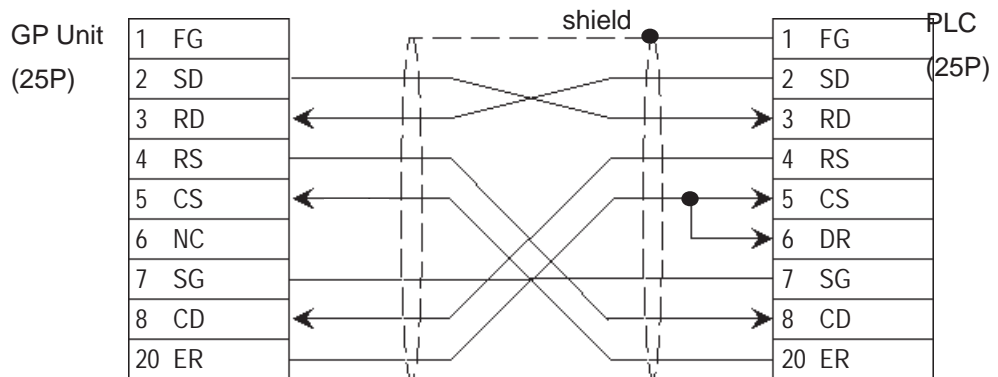

ST401 Unit

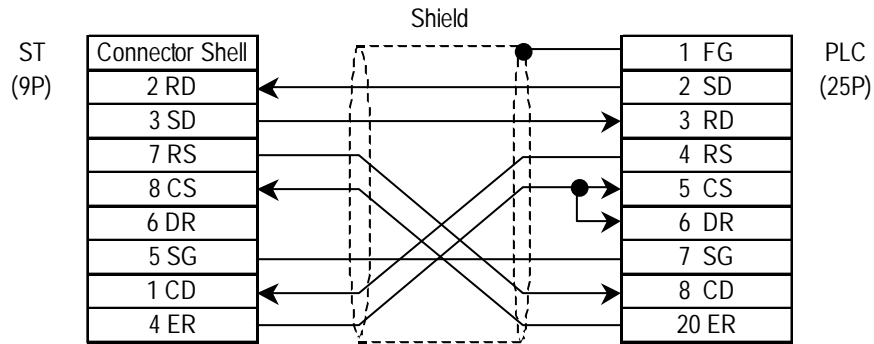

Cable Diagram 3 (RS-232C)

GP/GLC Series Units

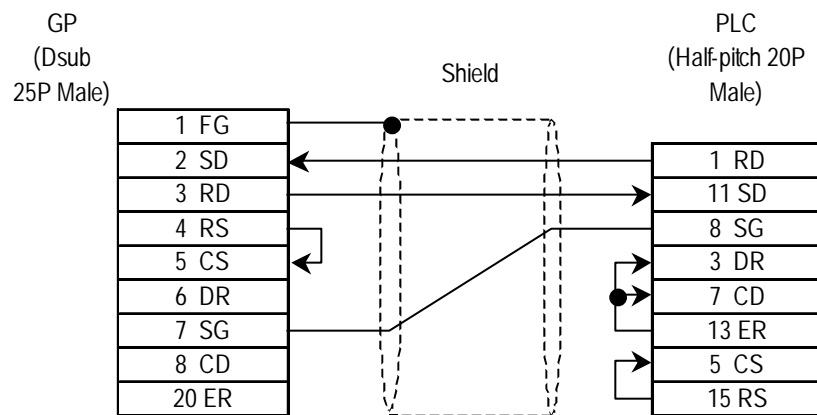

ST401 Unit

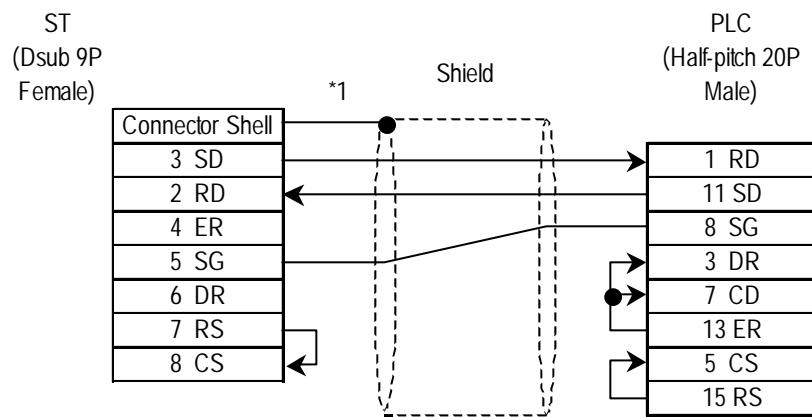

**1 Be sure to connect the shield to the Connector Shell. For information about FG connections, refer to page 1-2 "RS422 I/F (ST400)" section's Note, in the "Connecting a Device/PLC to the ST unit."*



- **Recommended Cable: Oki Densen's A66L-0001-0284#10P.**
- **When connecting the GP/GLC via a RS-422 cable, refer to Fanuc Corporation's manual for cable length.**

2.14.3 Supported Devices

The following describes the range of devices supported by the GP.

■ FANUC Power Mate Series Setup System Area here.

Device	Bit Address	Word Address	Remarks
Input Relay (X)	X000000 ~ X001277 X010000 ~ X010637	X00000 ~ X00126 X01000 ~ X01062	L/H
Output Relay (Y)	Y000000 ~ Y001277 Y010000 ~ Y010637	Y00000 ~ Y00126 Y01000 ~ Y01062	
Internal Relay (R)	R000000 ~ R009997	R00000 ~ R00998	
Keep Relay (K)	K00000 ~ K00197	K0000 ~ K0018	
Timer (T)	---	T0000 ~ T0078	
Counter (C)	---	C0000 ~ C0078	
Data Table (D)	---	D0000 ~ D01858	

- The address' High/Low relationship is as follows:

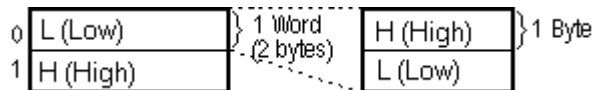

- When designating the *Input Relay*, *Output Relay*, *Internal Relay*, and *Data Table*, enter a 0, after each letter (X,Y,R,D). (The values in the table above already have a 0 added.)

E.g. X0 0120; Y0 01000

- A Host/PLC Communication Error will occur when an address outside the range is entered.

E.g. HOST COMMUNICATION ERROR (02 : 0F : * *)









**	Meaning	Solution
04	The entered address does not exist.	Check the range of available Motion Controller addresses, and setup all addresses within this range.
05	The entered data length is incorrect.	



Input Bit Address data using Decimal/Octal.

E.g. K0063 7
 Decimal └┘ └┘ Octal

■ FANUC Series

Device	Bit Address	Word Address	Remarks
Input Relay (X)	X000000 - X000127 X010000 - X011277	X00000 - X00126 X01000 - X01126	 *1
Output Relay (Y)	Y000000 - Y000127 Y010000 - Y011277	Y00000 - Y00126 Y01000 - Y01126	
Internal Relay (R)	R000000 - R079997	R00000 - R07998	
Keep Relay (K)	K000000 - K000197	K00000 - K00018	
Timer (T)	_____	T0000 - T0498	
Counter (C)	_____	C 0000 - C 0398 C 5000 - C 5198	
Data Table (D)	_____	D00000 - D08190	  *2

*1 Data write is not permitted.

*2 The maximum address available for bit access is the 7th digit of D02999.



The actual address range available will vary depending on the PLC unit's series. For detailed address information, please refer to your FANUC Corporation manual.



The address' High/Low relationship is as follows:

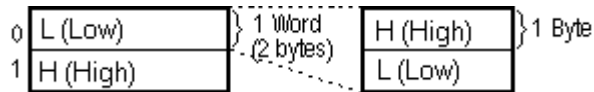

- When designating the *Input Relay*, *Output Relay*, *Internal Relay*, and *Data Table*, enter a 0, after each letter (X,Y,R,D). (The values in the table above already have a 0 added.)

E.g. **X0 0120**; **Y0 01000**

- A Host/PLC Communication Error will occur when an address outside the range is entered.

E.g. **HOST COMMUNICATION ERROR (02 : 0F : * *)**

**	Meaning	Solution
04	The entered address does not exist.	Check the range of available Motion Controller addresses, and setup all addresses within this range.
05	The entered data length is incorrect.	



Input Bit Address data using Decimal/Octal.

E.g. **K0063 7**
 Decimal Octal

2.14.4 Environment Setup

The following lists Digital's recommended Motion Controller and GP communication settings.

■ FANUC Power Mate Series

GP Setup		Motion Controller JD14 Setup
Baud Rate	19200 bps (fixed)	---
Data Length	8 bits (fixed)	---
Stop Bit	1 bit (fixed)	---
Parity Bit	Even (fixed)	---
Data Flow Control	ER Control (fixed)	---
Communication Format	4-wire type (fixed)	---
Unit No.	0 (fixed)	---

■ FANUC Series

GP Settings		JD5P Settings	
Baud Rate	19200bps(fixed)	_____	
Data Length	8bits(fixed)	_____	
Stop Bit	1bit(fixed)	_____	
Parity Bit	Even(fixed)	_____	
Data Flow Control	ER Control (fixed)	_____	
Communication Format	RS232C	_____	
Unit No.	0 (fixed)	_____	
_____	_____	Parameter 3119 - #3 (TPLDS)	0