

# Device/PLC Connection Manuals

---



## About the Device/PLC Connection Manuals

Prior to reading these manuals and setting up your device, be sure to read the "Important: Prior to reading the Device/PLC Connection manual" information. Also, be sure to download the "Preface for Trademark Rights, List of Units Supported, How to Read Manuals and Documentation Conventions" PDF file. Furthermore, be sure to keep all manual-related data in a safe, easy-to-find location.



## 12.2 Yokogawa M&C Controllers

### 12.2.1 System Structure

This chapter describes the system configuration used when connecting this Controller to the GP/GLC.

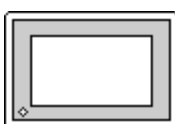

#### ■ UT2000 Series/GREEN SERIES

(1:1 communication)

Controller <sup>*1</sup>	Cable Diagram	GP/GLC
		
UT2400-□ UT2800-□ UT320-□1 UT350-□1 UT420-□7 UT450-□1 UT450-□2	RS-422 (4 wires) <Cable Diagram 1>	GP/GLC Series

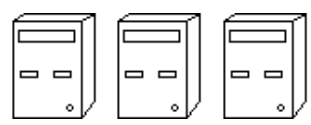

*\*1 The Controller's model number "□" will vary depending on each controller's functionality specifications.*

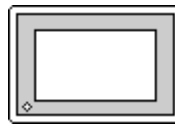
(1:n (multi-drop) Communication)

Controller <sup>*1</sup>	Cable Diagram	GP/GLC
		
UT2400-□ UT2800-□ UT320-□1 UT350-□1 UT420-□7 UT450-□1 UT450-□2	RS-422 (4 wires) <Cable Diagram 2>	GP/GLC Series



*\*1 The Controller's model number "□" will vary depending on each controller's functionality specifications.*

■ **UT3000**

Controller <sup>*1</sup>	Cable Diagram	GP/GLC
		
UT3040-□□1 UT3080-□□1 UT3160-□□1	RS-422 (1:1 connection) <Cable Diagram 3> RS-422 (1:n connection) <Cable Diagram 4>	GP/GLC Series

*\*1 The Controller's model number "□" will vary depending on each controller's functionality specifications.*

■ **UT100**

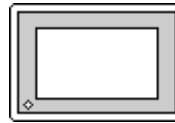
Controller <sup>*1</sup>	Cable Diagram	GP/GLC
		
UT130, UT150, UP150	RS-422 (1:1 connection) <Cable Diagram 5> RS-422 (1:n connection) <Cable Diagram 6>	GP/GLC Series
UT152, UT155	RS-422 (1:1 connection) <Cable Diagram 7> RS-422 (1:n connection) <Cable Diagram 8>	

### 12.2.2 Cable Diagrams

The cable diagrams shown below and those recommended by Yokogawa or Yokogawa M&C may differ, however, using these cable connections for your Controller's operations will not cause any problems.



- *Ground the Controller's FG terminal according to your country's applicable standard.*



**Important**

- *When connecting the FG wire to the cable connector's hood, be sure that the hood material is conductive.*
- *The maximum RS-422 cable length is 500 meters. When connecting this cable, be sure to connect the SG terminal.*

#### ■ Terminal Numbers Used When Using an RS-422 Cable



**Important**

- *The terminal numbers used when using an RS-422 cable for connection will vary depending on each Controller model.*

*On the cable diagram, however, these terminal numbers are not shown, and please refer to the numbers shown below for cable connection.*

#### ◆ UT2000 Series

Signal Name	Terminal No.
TX+	4
TX-	6
RX+	3
RX-	5
SG	2
FG	1

#### ◆ GREEN Series

Signal Name	Terminal No.
SDA(-)	24
SDB(+)	23
RDA(-)	26
RDB(+)	25
SG	27

**Cable Diagram 1 (1:1) (RS-422 4 Wires)**

<When using Digital's RS-422 connector terminal adapter GP070-CN10-0>

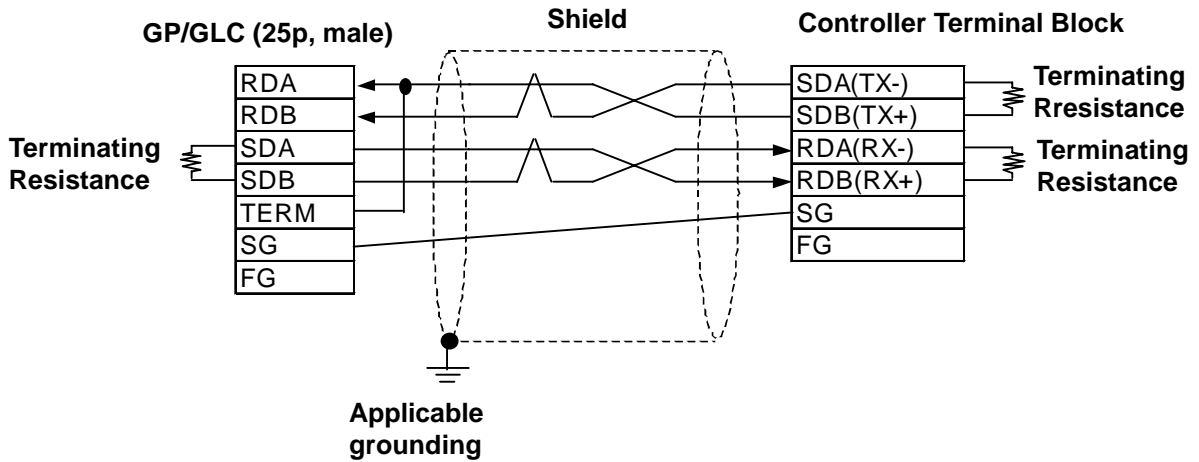

<When preparing a cable on your own specifications>

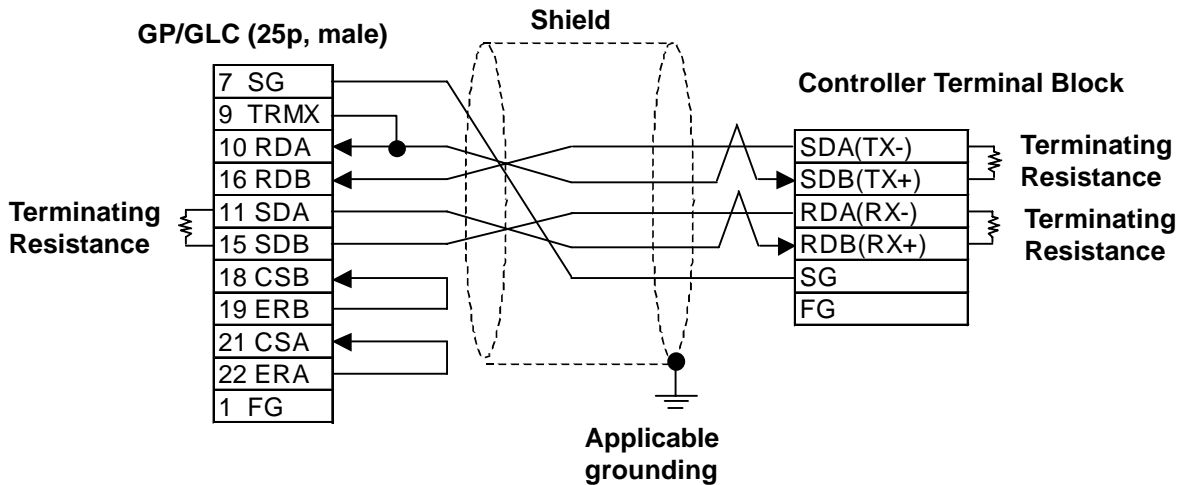

**Note:** Hitachi Densen's CO-SPEV-SB(A)3P\*0.5SQ cable is recommended.

Depending on the Controller model, the FG terminal may not be equipped.

The GREEN SERIES' terminating resistance is 220Ω (1/4W) and the UT2000 Series' terminating resistance is 100Ω(1/2W) or more.

Connecting the GP/GLC serial interface's Nos. 9 and 10 pins will insert 100Ω terminating resistance between RDA and RDB.

When using an RS-422 cable, be sure to keep its length within 500 meters.

**Cable Diagram 2 (1:n) (RS-422 4 Wires)**

<When using Digital's RS-422 connector terminal adapter GP070-CN10-0>

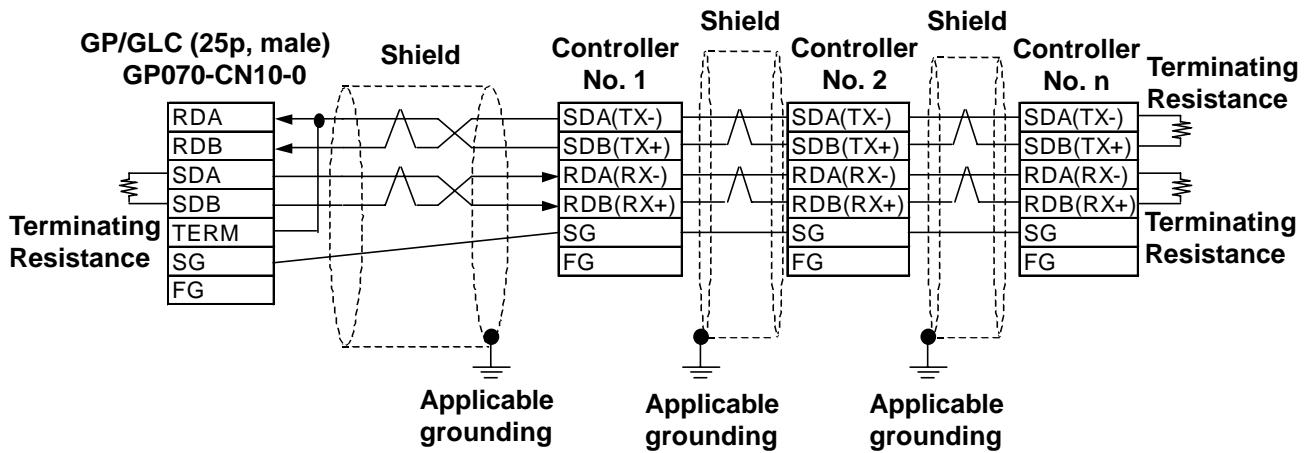

<When preparing a cable on your own specifications>

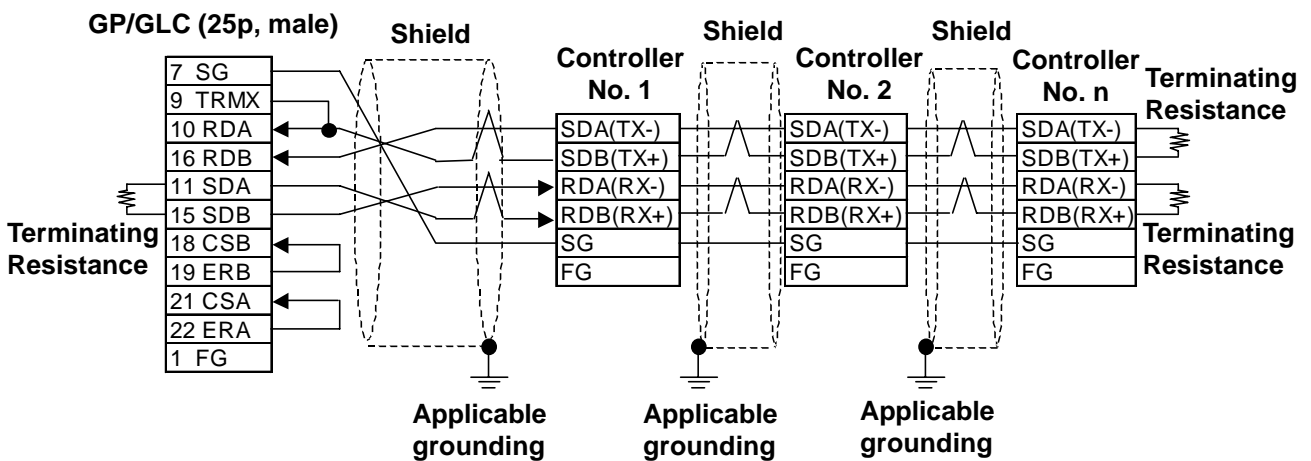

**Note:**

The maximum RS-422 (4 wires) cable length is 500 meters.

Up to 31 Controllers (up to 16 for UT2000 Series) can be connected.

Depending on the Controller model, the FG terminal may not be equipped.

The GREEN SERIES' terminating resistance is 220Ω(1/4W) and the UT2000 Series' terminating resistance is 100Ω(1/2W) or more.

**Cable Diagram 3 (1:1) (RS-422 4 Wires)**

<When using Digital's RS-422 connector terminal adapter CP-070-CN10-0>

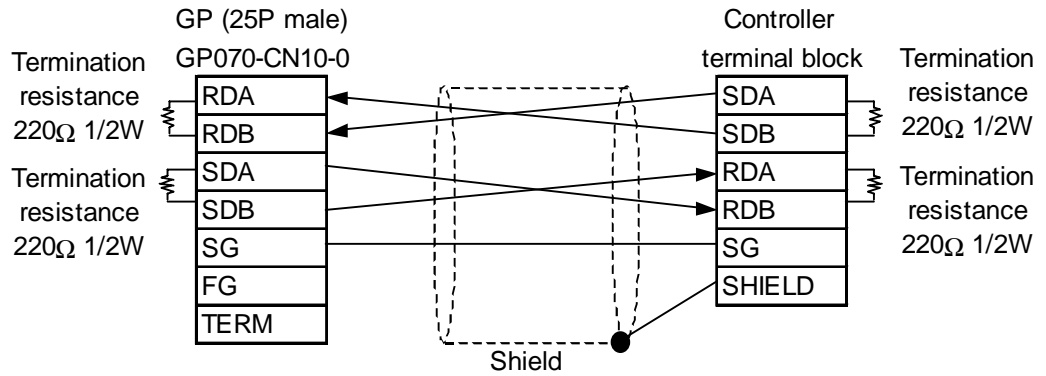

<When making your own cable>

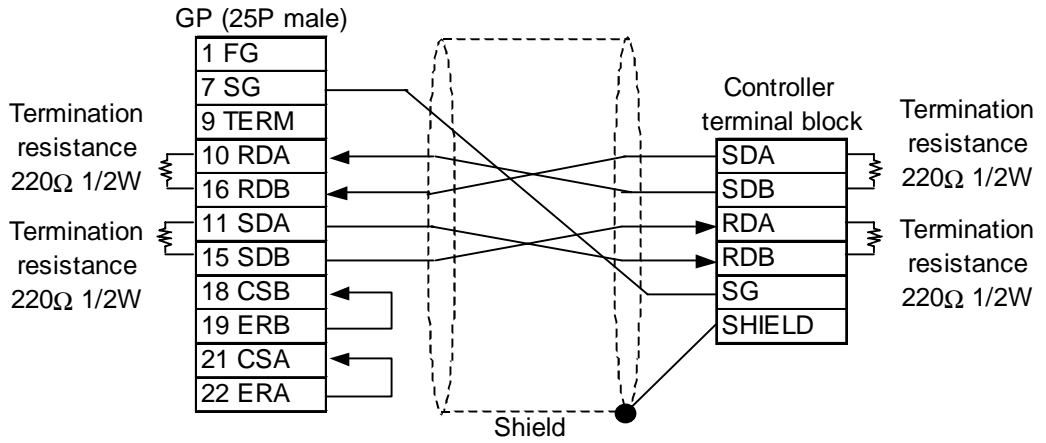

- **Maximum cable length is 600 m.**

**Cable Diagram 4 (1:n) (RS-422 4 Wires)**

<When using Digital's RS-422 connector terminal adapter CP-070-CN10-0>

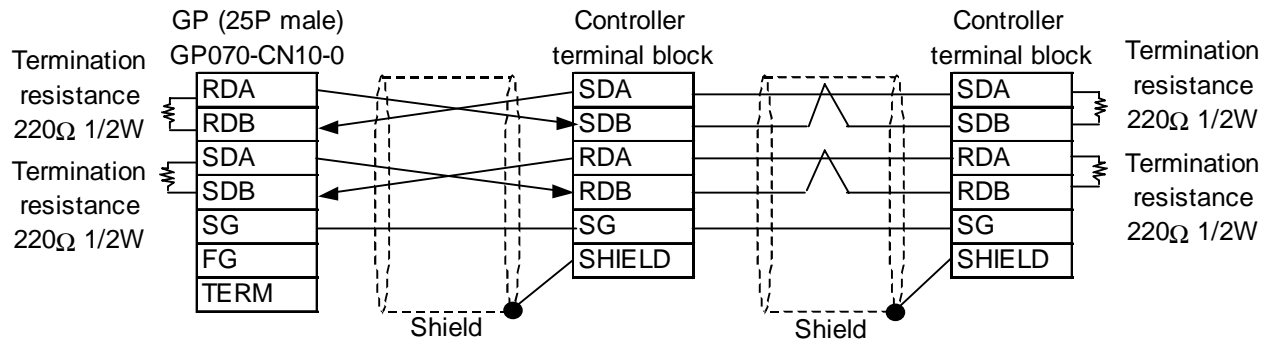

<When making your own cable>

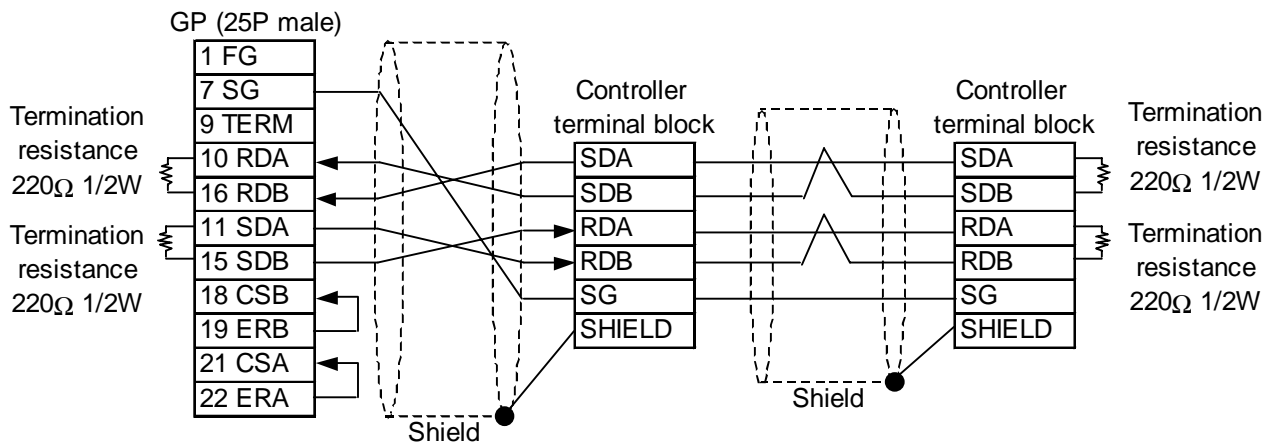

• **Maximum cable length is 600 m.**



**Cable Diagram 5 (1:1) (RS-422 2 Wires)**

<When using Digital's RS-422 connector terminal adapter CP-070-CN10-0>

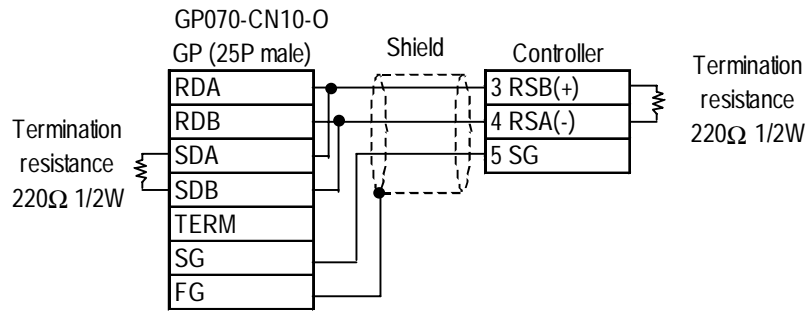

<When using Digital's RS-422 cable GP230-IS11-0>

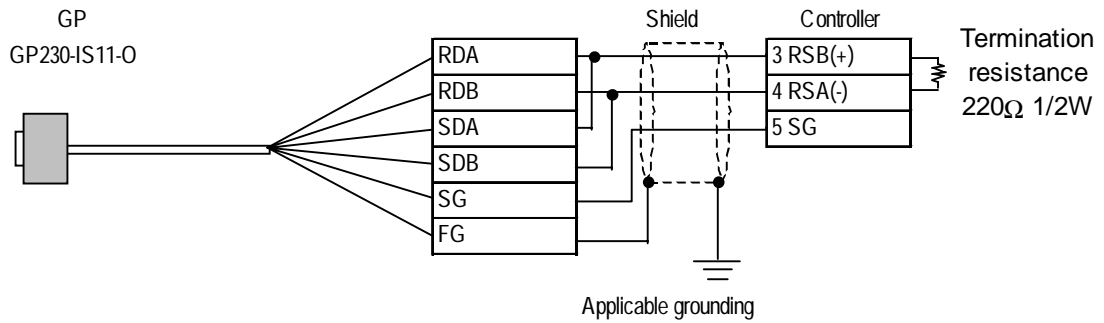

<When making your own cable>

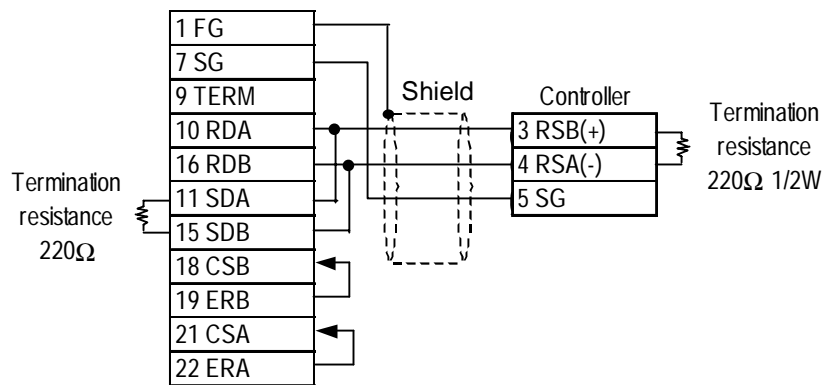

**Cable Diagram 6 (1:n) (RS-422 2 Wires)**

<When using Digital's RS-422 connector terminal adapter CP-070-CN10-0>

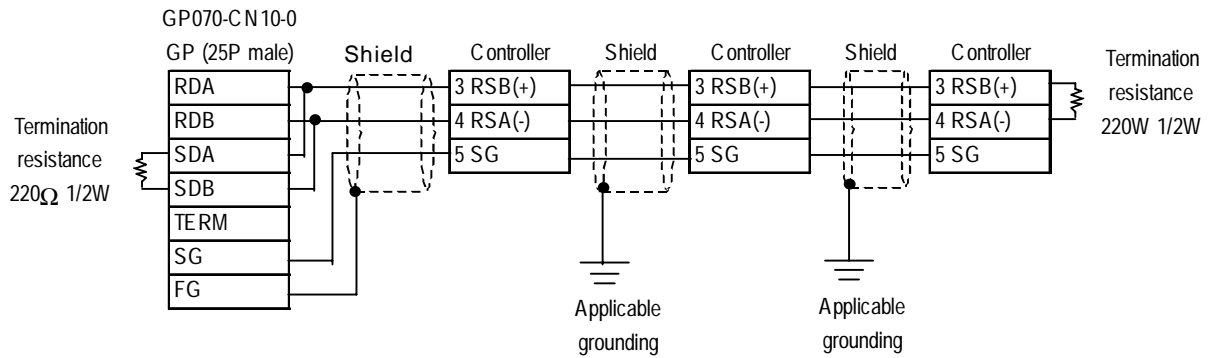

<When using Digital's RS-422 cable GP230-IS11-0>

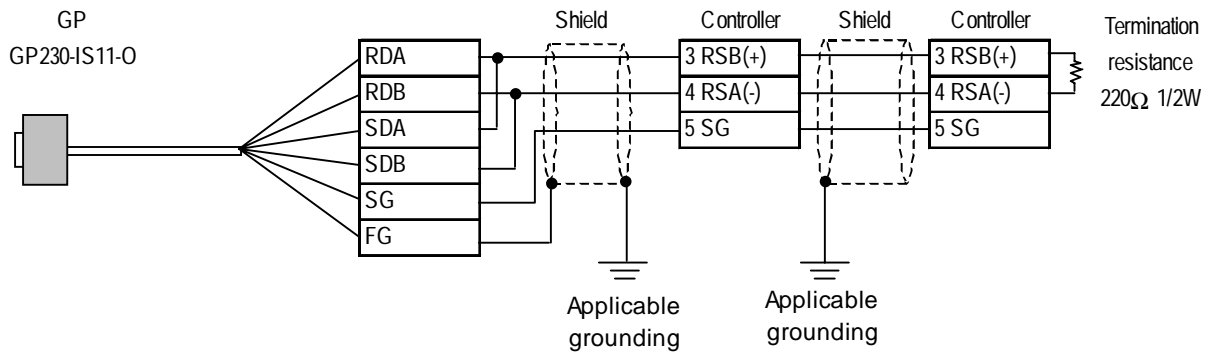

<When making your own cable>

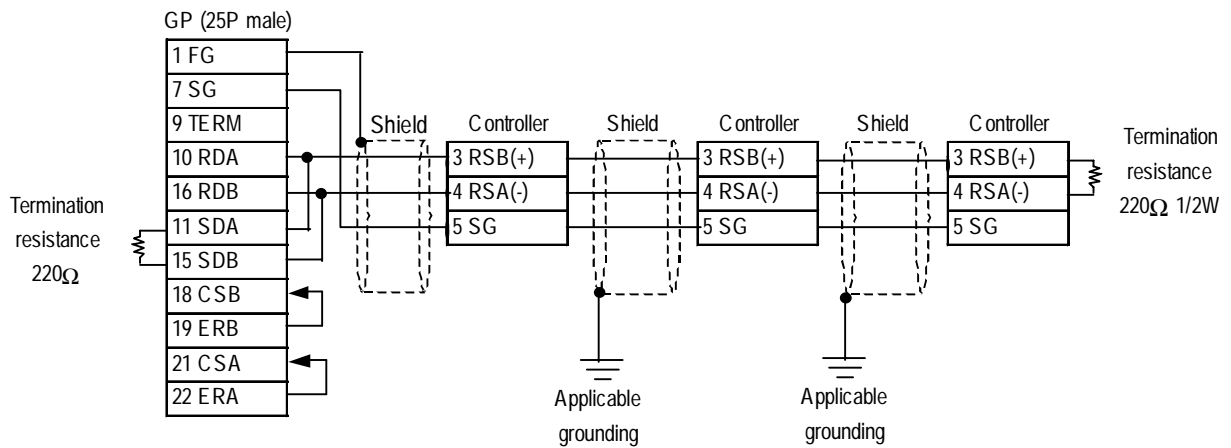

**Cable Diagram 7 (1:1) (RS-422 2 Wires)**

<When using Digital's RS-422 connector terminal adapter CP-070-CN10-0>

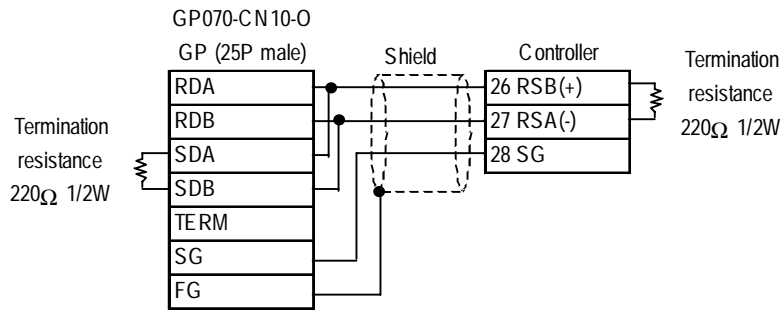

<When using Digital's RS-422 cable GP230-IS11-0>

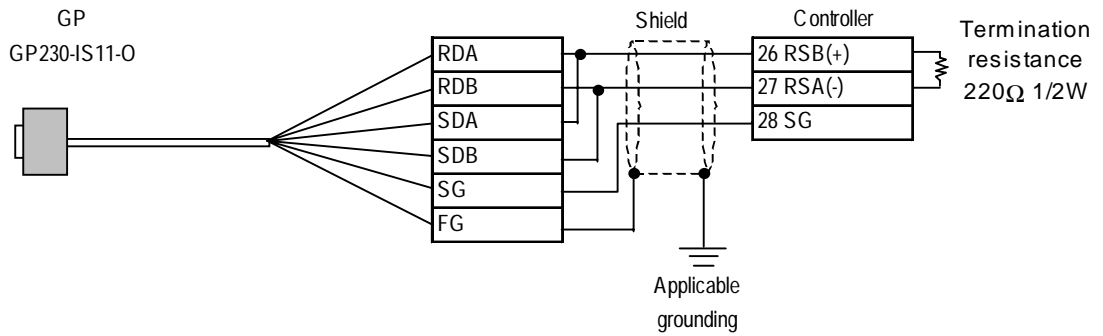

<When making your own cable>

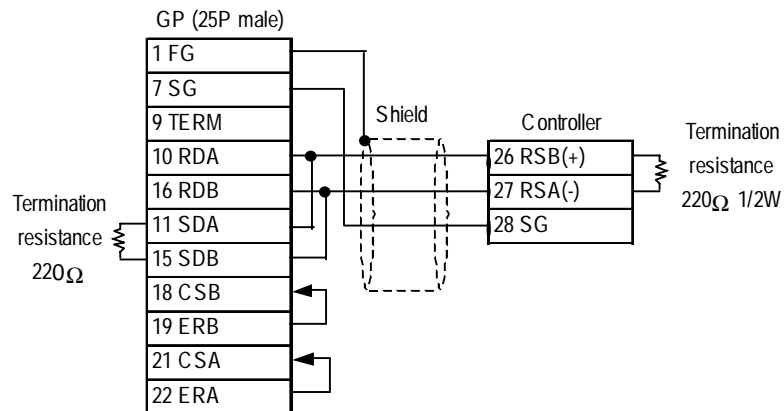

**Cable Diagram 8 (1:n) (RS-422 2 Wires)**

<When using Digital's RS-422 connector terminal adapter CP-070-CN10-0>

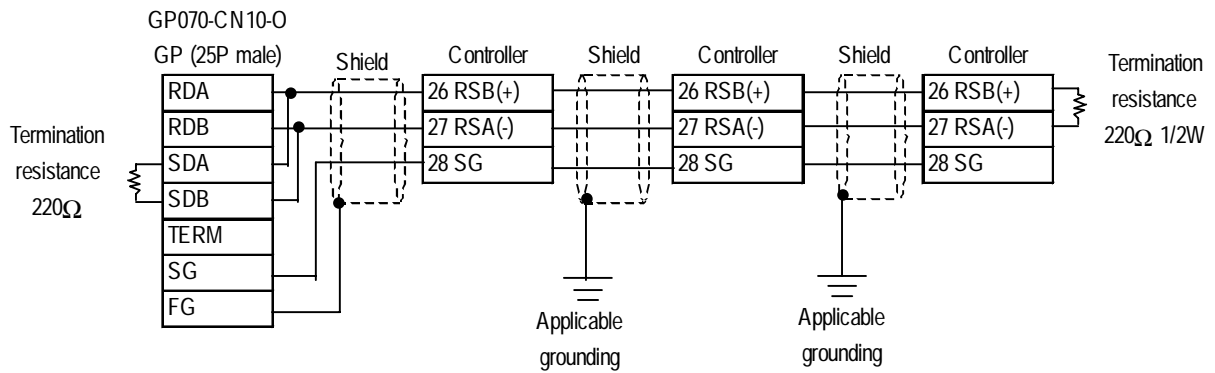

<When using Digital's RS-422 cable GP230-IS11-0>

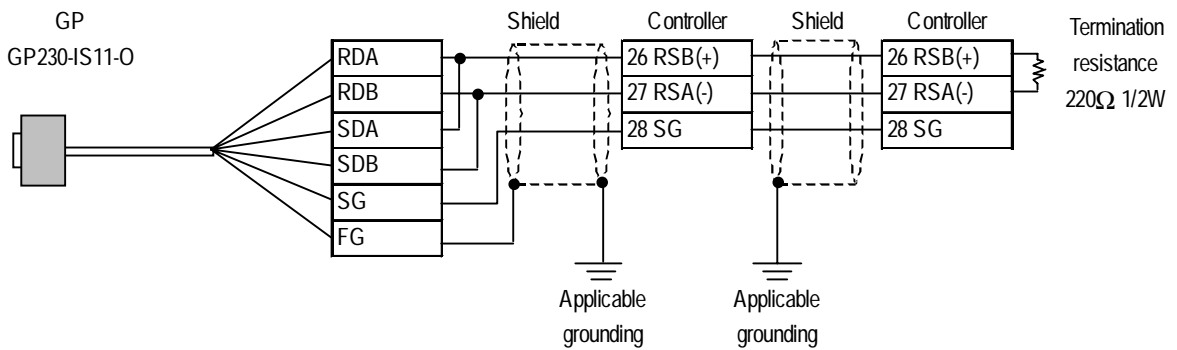

<When making your own cable>

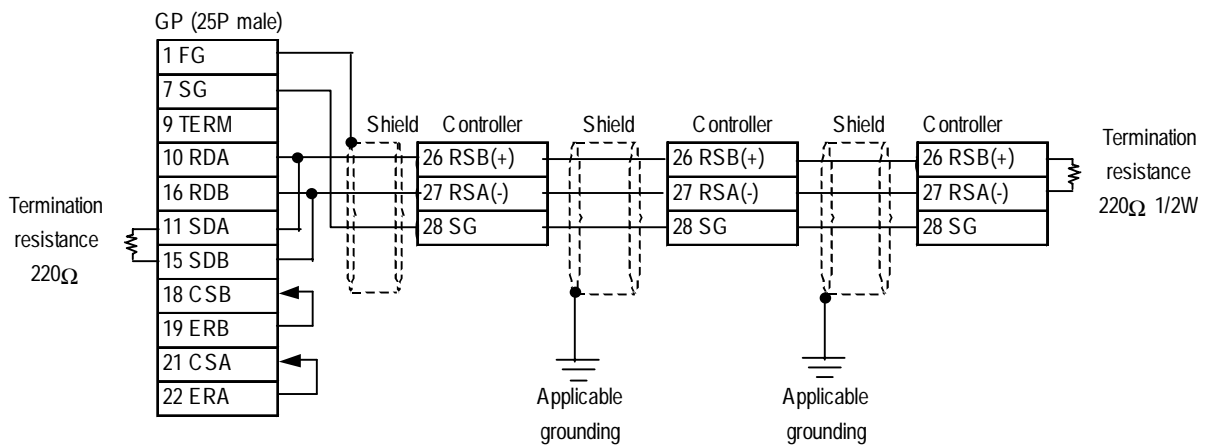

**12.2.3 Supported Devices**

The following lists show the ranges of devices supported by the GP/GLC.

**■ UT2000 Series**

Depending on the Controller model, prohibit areas are specified even within the following ranges.

**Reference** Refer to Yokogawa's "UT2000 Detailed operation manual"

Device	Bit Address	Word Address	Remarks
I	I0001 ~ I1024	I0001 ~ I1009	$\div 16 + 1$
D	—————	D0001 ~ D1024	Bit 5

L/H

**■ GREEN SERIES**

Depending on the Controller model, prohibit areas are specified even within the following ranges.

**Reference** Refer to Yokogawa M&C's "UT350/UT320 Digital Indicated Controllers Operation Manual" and "GREEN SERIES further User's Manual".

Device	Bit Address	Word Address	Remarks
I	I0001 ~ I2048	I0001 ~ I2033	$\div 16 + 1$
D	—————	D0001 ~ D1274	Bit 5

H/L



- **The system area (20 words) cannot be allocated to the Controller's own data area. Even though you can enter the system area settings via the GP screen editor software, or via the OFFLINE screen, it is impossible to actually allocate the system area to the Controller's data area.**
- **Be careful as the Device fields differ depending on the type of Controller. Refer to the Controller's manual for the range allowed for the device address area.**  
**After screen data is converted from a different type of Controller, be sure to check if the device addresses used are correct. Be sure to check the supported device addresses before using Trend graphs or tags in your screens that use multiple words over continuous addresses.**



**Note:** When using tags in the screen editor software, the PLC Station number can be designated during address input. When a station number is not designated, the previously entered station number is automatically used. (The default value is 1.)

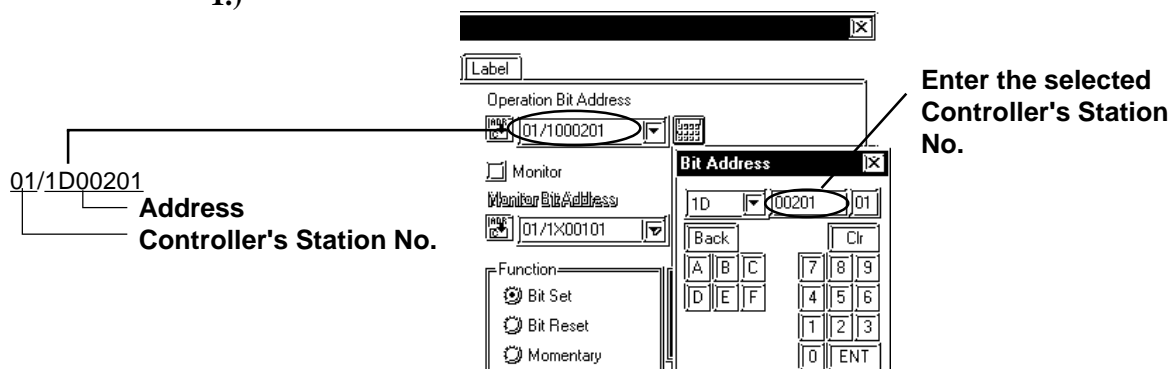

■ UT3000

Device	Bit Address	Word Address	Remarks
D-register	_____	D0101 ~ D3206	*1 *2 *3
I-relay	I0001 ~ I1024	I0001 ~ I0497	*1 L/H
W-register	_____	W0101 ~ W1606	

\*1 Writing a value to any write-protected address will not result in an error, however that value will not be reflected.

\*2 The T-tag cannot be used to write a value to an address that is not used by a parameter between loops (e.g., an address from D207 to D300 that are not used and is between loops 1 and 2).

\*3 Yokogawa's FACTORY ACE 1:n communication protocol only allows you to specify addresses D00001 to D02047. For addresses D02048 or larger, use the W-device. For the address maps of the W-register and D-register, refer to the list of D-registers/I-relays in the PC-LINK communication interface volume of the user's manual for UT3000 network temperature controller.



- **System information is stored at D0001 to D0040. Therefore, do not write any value to these addresses. If any illegal value is written to such an address, the RUN LED on the CPU will turn OFF and the ERR LED will turn ON. Data will be sent, but the UT3000 will not operate. Since the default value for the first address in the system area is D0001, be very careful of the above point. Either change the first address in the system area in the GP-PRO/PBIII for Windows in advance or do not use the system area.**

## ■ UT100

### ◆ 1:1 communication

Device	Bit Address	Word Address	Remarks
D-register	—————	d1 ~ d32768	 *1 *2 *3 L/H

### ◆ 1:n communication

Device	Bit Address	Word Address	Remarks
D-register	—————	d1 ~ d2047	 *1 *2 *3 L/H

\*1 Some devices are write-protected. For their addresses, refer to Yokogawa M&C's TU100 series user's manual.

\*2 Only d401 to d420 may be allocated as system area memory for the controller. Be careful of this point when the system area is set in GP-PRO/PBIII for Windows or in the GP/GLC's OFFLINE mode.

\*3 This protocol is shared by Yokogawa's PLC. When a screen is set up in GP-PRO/PBIII, even though many values may be input for the PLC's devices, only d is available for a UT100 series controller.

### 12.2.4 Environment Setup

The following list shows the recommended Controller and GP/GLC communication settings.

#### ■ UT2000 Series/GREEN SERIES

GP/GLC Settings			Controller Settings		
Baud Rate	9600 bps		Baud Rate	9600 bps	
Data Length	8 bit		Data Length	8 bit	
Stop Bit	1 bit		Stop Bit	1 bit	
Parity Bit	Even		Parity Bit	Even	
Data Flow Control	ER		---	---	
Communication Format (When using RS-422)	4-wire Type		---	---	
---	---	---	For Dip Switch Communication Mode Selection	UT2000 Series	ON
			Protocol Selection (PSL)	GREEN SERIES	Personal computer link communication
Unit No.	UT2000 Series	1 ~ 16	Station No. (communication address)	UT2000 Series	1 ~ 16
	GREEN SERIES	1 ~ 31		GREEN SERIES	1 ~ 31

#### ◆ Controller Communication Settings

<UT2000 Series>

Use the unit's rear face rotary switches:

- (1) Use the communication condition setting rotary switch to enter the communication condition.
- (2) Use the station number selection rotary switch to enter the unit number.
- (3) Turn the communication mode selection dip switch ON.

<GREEN SERIES>

Use the unit's front keys:

- (1) Hold down the Controller's [SET/ENT] key for 3 seconds or more to change the screen from [operation] to [operation parameter] .
- (2) When "OP.PA" appears on the measurement value (PV) display, use either  $\Delta$  or  $\nabla$  key to display "STUP".
- (3) For UT350/UT320, every time you press the [SET/ENT] key, the screen will change one by one, in the order of [Protocol Selection] --> [Baud Rate] --> [Parity] --> [Stop Bit] --> [Data Length] --> [Communication Address].

For UT450/UT420, press the [SET/ENT] key once, and the [Setup Parameter Settings] screen will appear. Use either  $\Delta$  or  $\nabla$  key to select "r485", and then, press the [SET/ENT] key again. After this, use the same procedure used for UT350/UT320.



■ **UT3000**

GP/GLC Settings		Controller Settings	
Baud Rate	9600 bps	Baud Rate	9600 bps
Data Length	8 bits	Data Length	8 bits
Stop Bit	1 bit	Stop Bit	1 bit
Parity Bit	None	Parity Bit	None
Data Flow Control	ER Control	Sum Check	ON
Communication Format	4-wire Type	Designation of Terminating Character	None
Unit No.	1	Protection	None
—		Station No.	1

■ **UT100**

GP/GLC Settings		Controller Settings <sup>*1</sup>		Settings
Baud Rate	9600 bps	Baud Rate	9600 bps	BPS: 9.6
Data Length	8 bits	Data Length	8 bits	DLN: 8
Stop Bit	1 bit	Stop Bit	1 bit	STP: 1
Parity Bit	Even	Parity Bit	Even	PR1: EVN
Control Method	ER Control	—	—	—
Communication Format	2-wire Type	Communication Format	RS-485 Communication	—
Unit No.	1	Communication Address <sup>*2</sup>	1	ADR: 1
—		Protocol	PC Link Communication (without Sum Check)	PSL: 0

*\*1. In order to comply with Yokogawa M&C's UT100 series controller, the existing Yokogawa's PLC protocol has been expanded. The default values for the GP/GLC remain unchanged to comply with the PLC. To communicate with the controller, change the communication settings to those for the controller.*

*\*2. The communication addresses for the controller can be specified in a range between 1 and 99. However, those for setting parts and tags on the GP-PRO/PBIII are only allowed in a range between 1 and 32. Only communication between a single GP/GLC unit and a maximum of 31 controllers is possible. Therefore, take care not to specify wrong communication addresses for the controllers.*