

Device/PLC Connection Manuals



About the Device/PLC Connection Manuals

Prior to reading these manuals and setting up your device, be sure to read the "Important: Prior to reading the Device/PLC Connection manual" information. Also, be sure to download the "Preface for Trademark Rights, List of Units Supported, How to Read Manuals and Documentation Conventions" PDF file. Furthermore, be sure to keep all manual-related data in a safe, easy-to-find location.

12.6 Shinko Technos Controllers

12.6.1 System Structure

The following describes the system configuration used when connecting the GP/GLC to this Controller.



- **Do not use the system area because the GP/GLC's system area (LS0 to LS19) cannot be allocated to the Controller area. (Deselect all system area selection items.)**
- **The Controller's read area can be used as normal.**

■ C Series

CPU	Control Unit*1	Cable Diagram	Cables	GP
CPT-20A	CCT-235-2-□□	RS-422 <Cable Diagram 4>	CPM Shinko Technos Corporation	GP series GLC series
		RS-422 (1:n) <Cable Diagram 5>	CPM and CPP Shinko Technos Corporation	

**1 The Controller's model number "□□" changes, according to the options selected. For details about model numbers, refer to the C Series catalog.*

■ FC Series

Controller *1	Link I/F	Cable Diagram	GP
FCD-13A□□,C FCD-15A□□,C FCR-13A□□,C FCR-15A□□,C	Serial Communication Option:C	RS-232C <Cable Diagram 1>	GP Series GLC Series
FCD-13A□□,C5 FCD-15A□□,C5 FCR-13A□□,C5 FCR-15A□□,C5	Serial Communication Option:C5	RS-422 <Cable Diagram 2> RS-422 (1:n) <Cable Diagram 3>	

**1 The Controller's model number "□□" varies depending on the option selected.*

Items with the serial communication option have a ",C" or ",C5" after the basic model number.

For details about model numbers, refer to each series catalog.

■ FIR Series

Controller *1	Link I/F	Cable Diagram	GP
FIR-201-M□□,C FIR-201-M□□,C	Serial Communication Option:C	RS-232C <Cable Diagram 1>	GP Series GLC Series
FIR-201-M□□,C5 FIR-201-M□□,C5	Serial Communication Option:C5	RS-422 <Cable Diagram 2>	
		RS-422 (1:n) <Cable Diagram 3>	

■ GC Series

Controller *1	Link I/F	Cable Diagram	GP
GCS-300□□,C5	Serial Communication Option:C5	RS-422 <Cable Diagram 2>	GP Series GLC Series
		RS-422 (1:n Communication) <Cable Diagram 3>	

■ FCL Series

Controller *1	Link I/F	Cable Diagram	GP
FCL-13A□□,C5	Serial Communication Option:C5	RS-422 <Cable Diagram 2>	GP Series GLC Series
		RS-422 (1:n Communication) <Cable Diagram 3>	

■ PC-900 Series

Controller *1	Link I/F	Cable Diagram	GP
PC-935□□,C PC-955□□,C	Serial Communication Option:C	RS-232C <Cable Diagram 1>	GP Series GLC Series
PC-935□□,C5 PC-955□□,C5	Serial Communication Option:C5	RS-422 <Cable Diagram 2>	
		RS-422 (1:n Communication) <Cable Diagram 3>	

*1 The Controller's model number "□□" changes, depending on the options selected.

Units with the serial communication option have a "C" or "C5" after the basic model number.

For details about model numbers, refer to each series unit's catalog.

■ PCD-33A Series

Controller	Link I/F	Cable Diagram	GP/GLC
PCD-33A-□/M□, □ C5	Serial Communication Option: C5 RS-232C <-> RS-485 Converter IF-300-C5 (Shinko Technos Corporation)	RS-232C <Cable Diagram 6>	GP Series GLC Series
		RS-232C (1:n Communication) <Cable Diagram 8>	
	Serial Communication Option: C5	RS-422 <Cable Diagram 7>	
		RS-422 (1:n Communication) <Cable Diagram 9>	

■ JCR-33A/JCD-33A Series

Controller	Link I/F	Cable Diagram	GP/GLC
JCR-33A-R/M□, □ C5	Serial Communication Option: C5 RS-232C <-> RS-485 Converter IF-300-C5 (Shinko Technos Corporation)	RS-232C <Cable Diagram 6>	GP Series GLC Series
		RS-232C (1:n Communication) <Cable Diagram 8>	
	Serial Communication Option: C5	RS-422 <Cable Diagram 7>	
		RS-422 (1:n Communication) <Cable Diagram 9>	

■ JIR-301-M Series

Controller	Link I/F	Cable Diagram	GP/GLC
JIR-301-M□, □ C5	Serial Communication Option: C5 RS-232C <-> RS-485 Converter IF-300-C5 (Shinko Technos Corporation)	RS-232C <Cable Diagram 6>	GP Series GLC Series
		RS-232C (1:n Communication) <Cable Diagram 8>	
	Serial Communication Option: C5	RS-422 <Cable Diagram 7>	
		RS-422 (1:n Communication) <Cable Diagram 9>	

■ DCL-33A Series

Controller	Link I/F	Cable Diagram	GP/GLC
DCL-33A-□/M□, □ C5	Serial Communication Option: C5 RS-232C <-> RS-485 Converter IF-300-C5 (Shinko Technos Corporation)	RS-232C <Cable Diagram 6>	GP Series GLC Series
		RS-232C (1:n Communication) <Cable Diagram 8>	
	Serial Communication Option: C5	RS-422 <Cable Diagram 7>	
		RS-422 (1:n Communication) <Cable Diagram 9>	

◆ When connecting an RS-232C cable (for RS232C compatible Controllers)

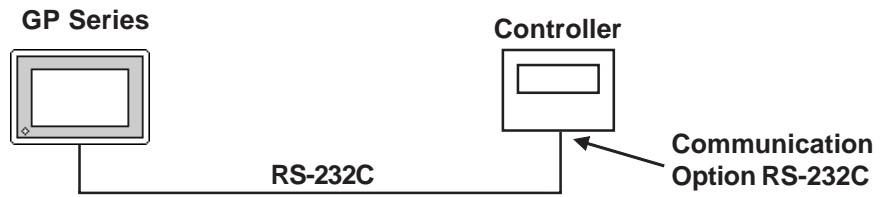

◆ RS-485 cable (except the C Series Controller)

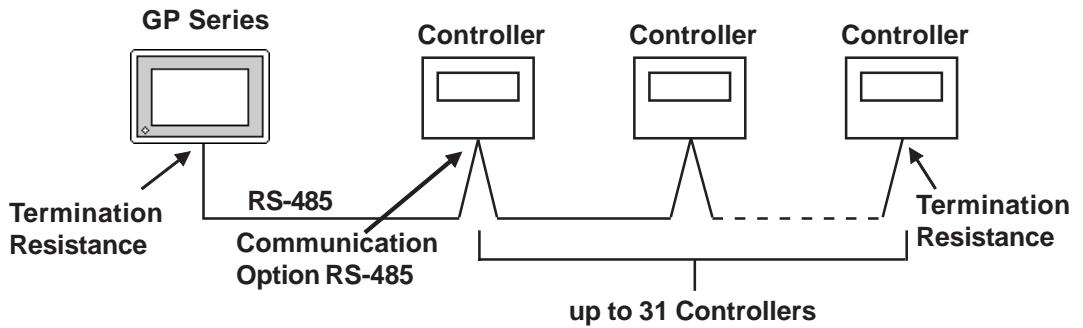

◆ RS-485 cable (connecting with the C Series Controller)

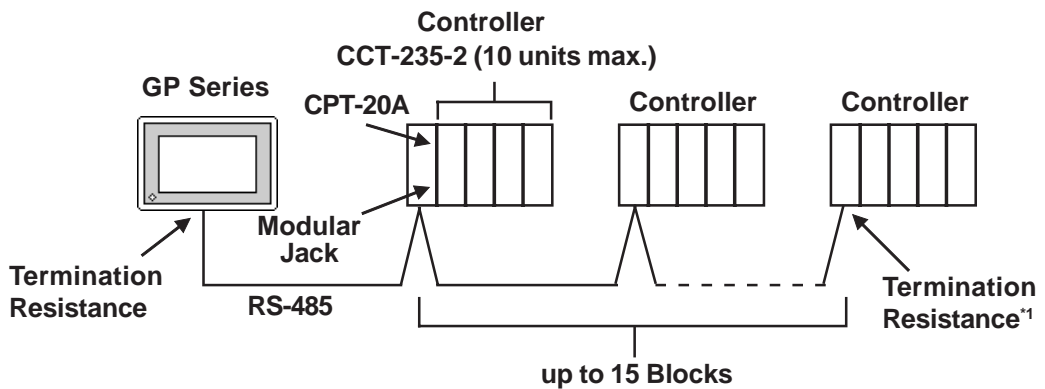

*1 Turn Controller's termination resistance switch ON.

12.6.2 Cable Diagrams

The cable diagrams shown below and the cable diagrams recommended by Shinko Technos Corporation may differ, however, using these cables for your Controller’s operations will not cause any problems.



- **Ground your PLC’s FG terminal according to your country’s applicable standard.**
- **Since some Controllers do not have a GND signal (FG), be careful when selecting the side (GP or Indicating Controller) used for connecting the FG wire to the shield.**
- **When connecting the FG wire to the cable connector’s cover, be sure it is made from a conductive material.**
- **For an RS-232C cable, use a cable length of 15 meters or less.**
- **For an RS-422 cable, use a cable length of 600 meters or less.**
- **Digital recommends the OTSC-2PVB-7/0.32TA cable, made by O-NAMBA Corporation.**

Cable Diagram 1

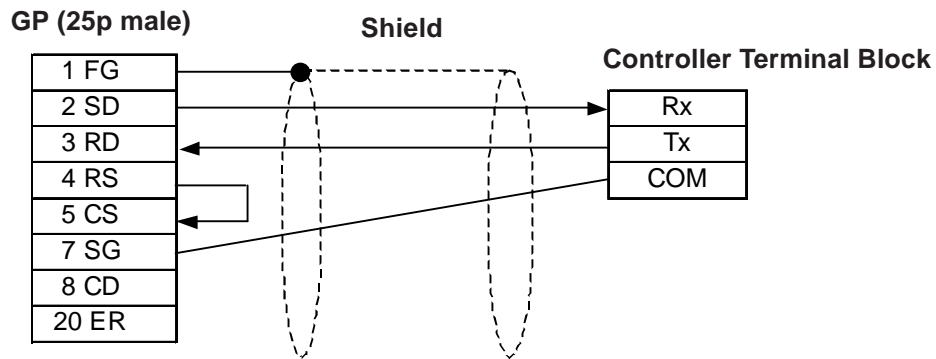

Cable Diagram 2

There are two ways of connecting the GP and the Controller. One is using the Shinko Technos' RS-232C ↔ RS-485 Converter (IF-300-C5). The other is using an RS-485 cable.

<When using Shinko Technos's RS-232C ↔ RS-485 Converter (IF-300-C5)>

When using this converter, be sure the GP's communication setting is "RS-232C". Do not use any other manufacturer's converter.

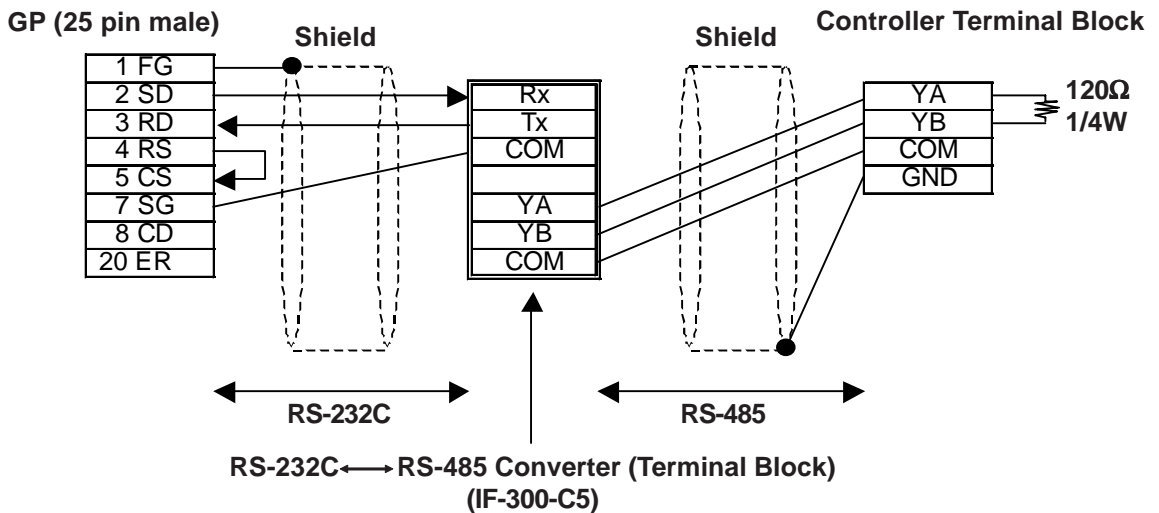

<When connecting the GP and the Controller with RS-485 cable>

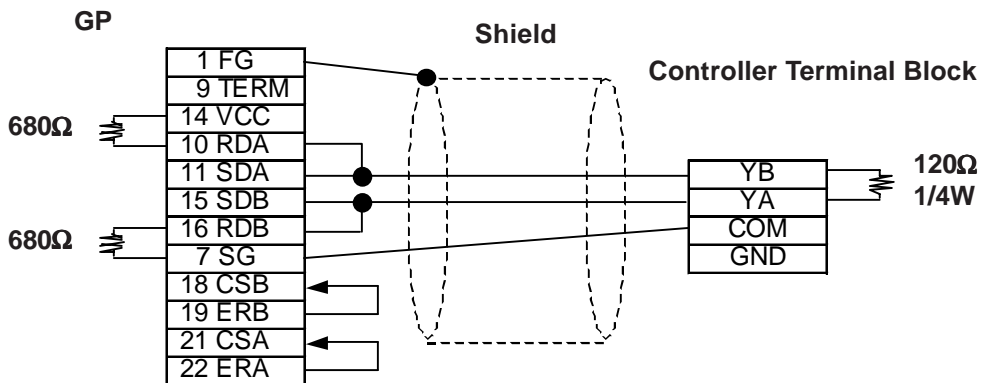

Cable Diagram 3

There are two ways of connecting the GP and the Controller. One is using the Shinko Technos' RS-232C ↔ RS-485 Converter (IF-300-C5). The other is using an RS-485 cable.

<When using Shinko Technos's RS-232C ↔RS-485 Converter (IF-300-C5)>

When using this converter, be sure the GP's communication setting is "RS-232C". Do not use any other manufacturer's converter.

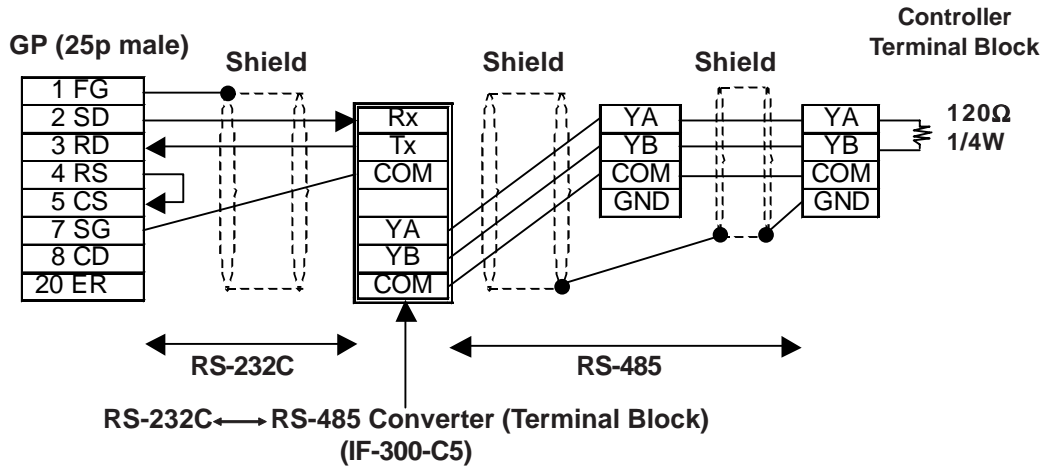

<When connecting the GP and the Controller via RS-485 cable>

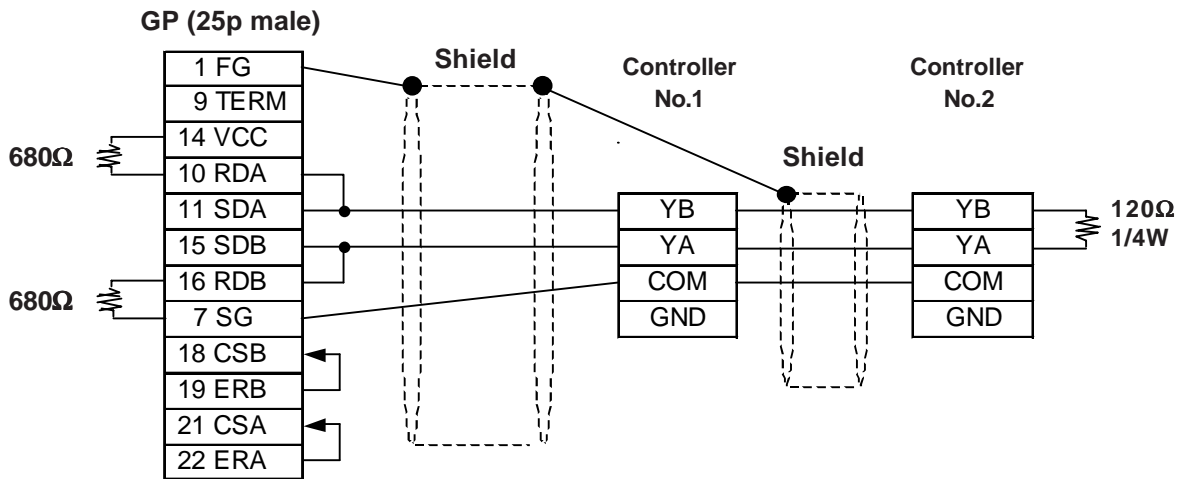

Cable Diagram 4 (RS-422)

<When using Digital's RS-422 connector terminal adapter GP070-CN10-O>

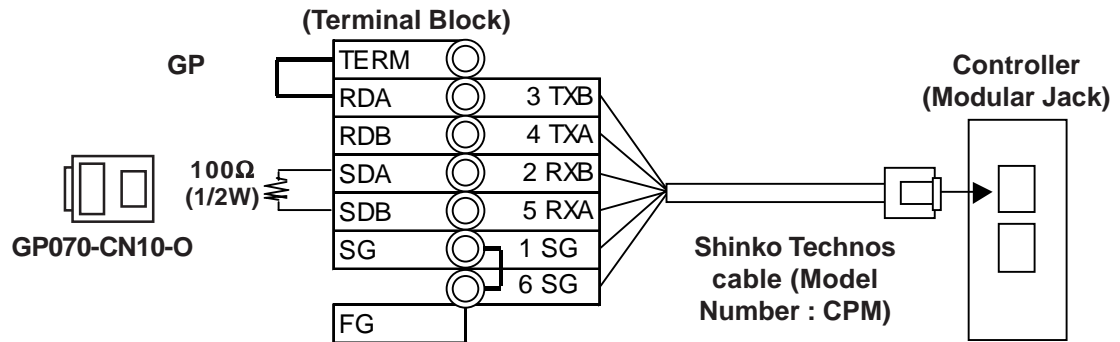

Note: Be sure to use only the Shinko Technos Corporation “CPM” cable.

Cable Diagram 5 (RS-422)

<When using Digital's RS-422 connector terminal adapter GP070-CN10-O>

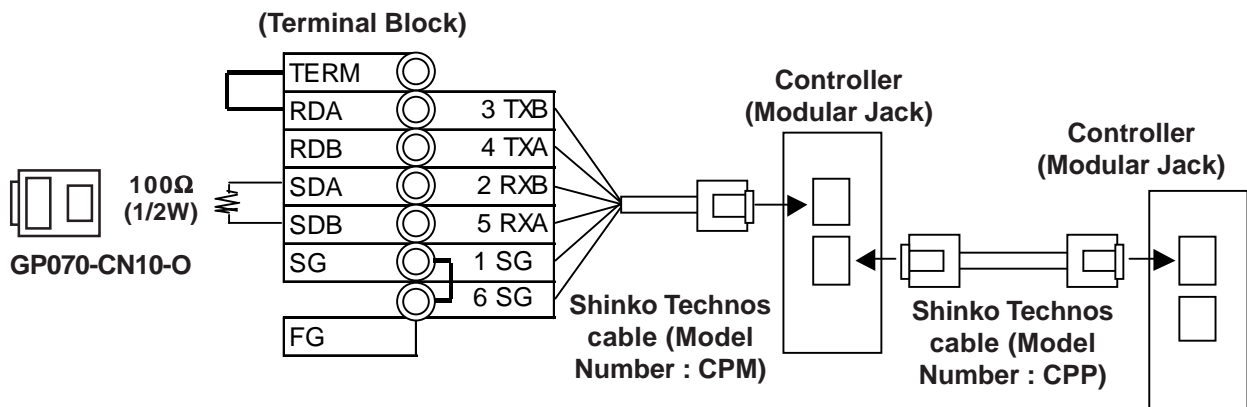

- Be sure to use only the Shinko Technos Corporation “CPM” and “CPP” cables.
- Be aware the A and B signals of the GP and PLC are reversed.
- To enable the Controller’s termination resistance, turn dip switch No.2 ON.

Cable Diagram 6 RS-422 (Maximum cable length: 15m)

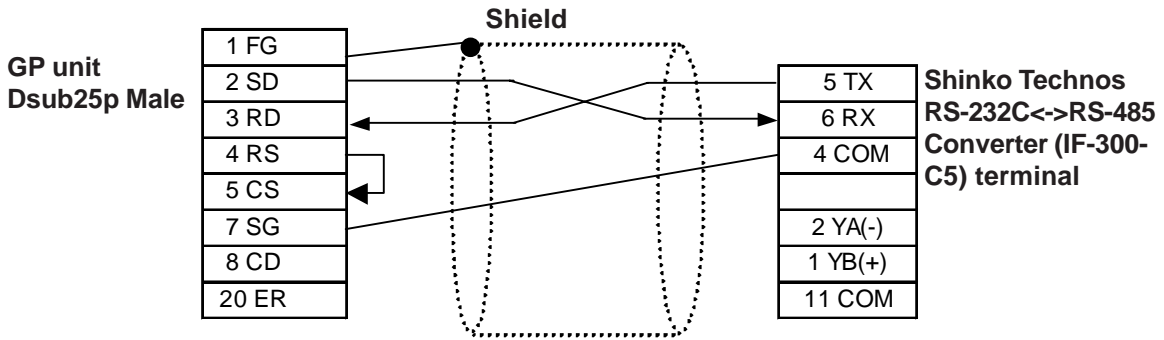

When connecting the Converter (IF-300-C5) to the Controller

<Maximum cable length: 600m (Except for DCL-33A series units)>

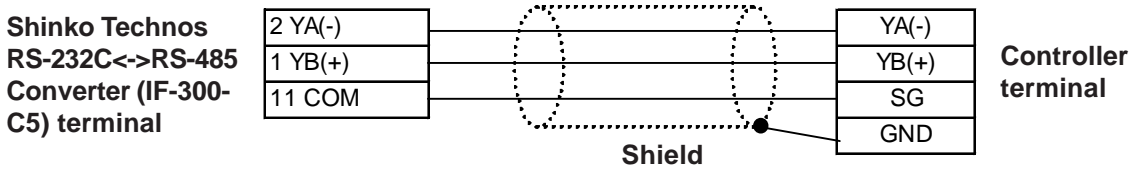

Additional termination resistance is not required, since it is already built into the Converter (IF-300-C5) as well as the Controller.

<When using DCL-33A series units>

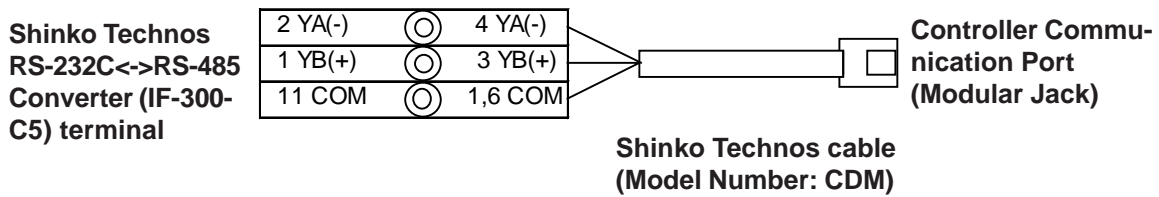

Cable Diagram 7

2-Wire type (When connecting the GP unit directly to the Controller)

<Maximum cable length: 600m (Except for DCL-33A series units)>

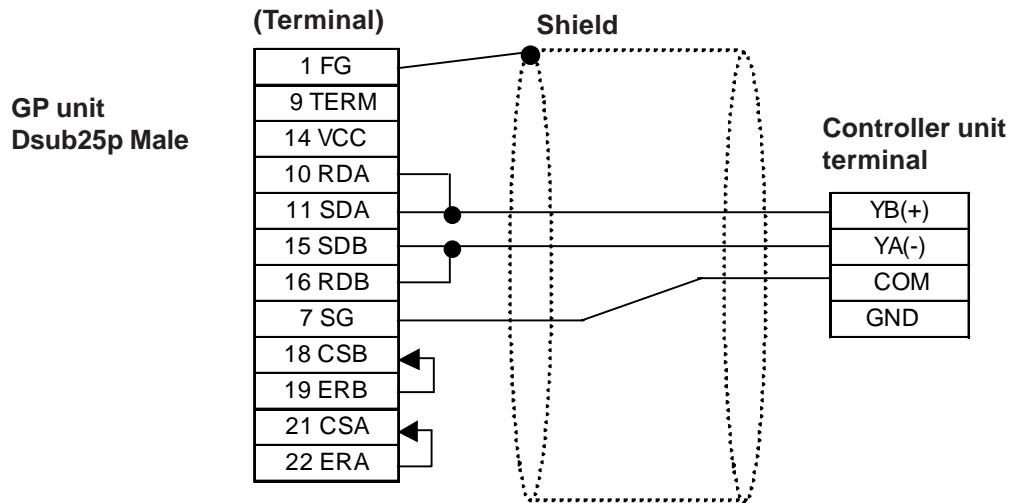

When using Digital's RS-422 connector terminal adapter GP070-CN10-O

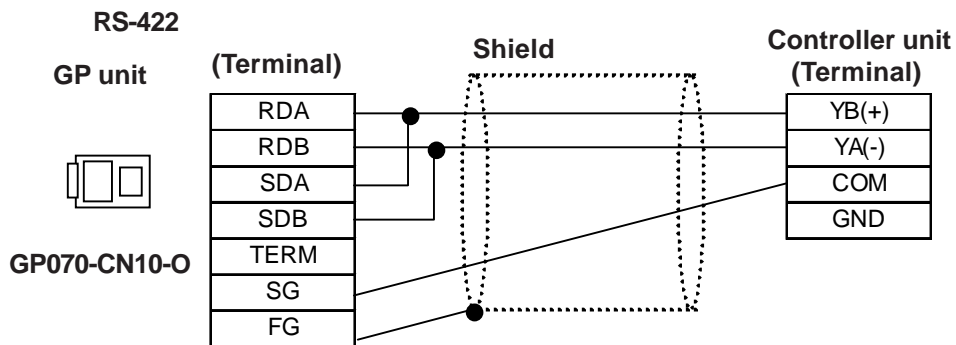

Additional termination resistance is not required, since it is already built into the Controller.

<When using DCL-33A series units>

When using Digital's RS-422 connector terminal adapter GP070-CN10-O

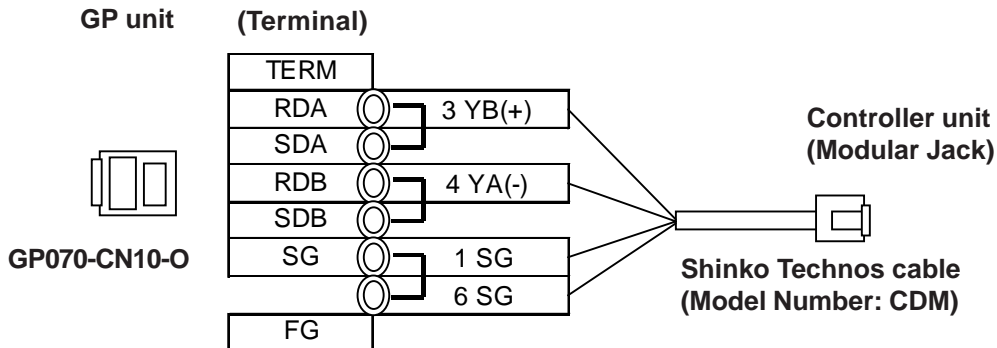

Cable Diagram 8

2-Wire type (1:n, When using the Shinko Technos Converter IF-300-C5)

<Total cable length: 600m (Except for DCL-33A series units)>

**Shinko Technos
RS-232C<->RS-485
Converter (IF-300-
C5) terminal**

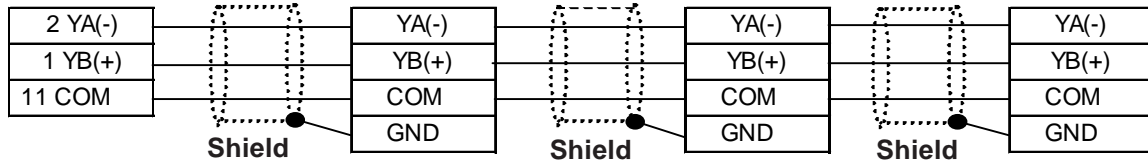

Additional termination resistance is not required, since it is already built into the Controller.

<When using DCL-33A series units>

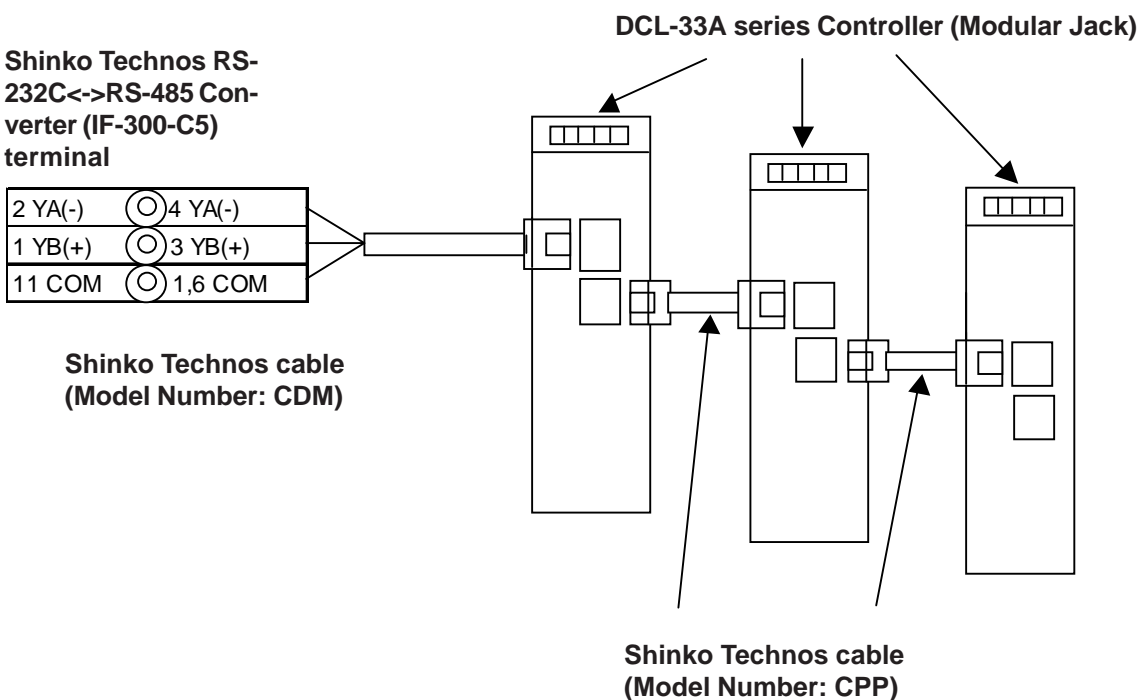

Cable Diagram 9

2-Wire type (1:n, When connecting the GP unit directly to the Controller)

<Total cable length: 600m (Except for DCL-33A series units)>

GP unit
Dsub25p Male

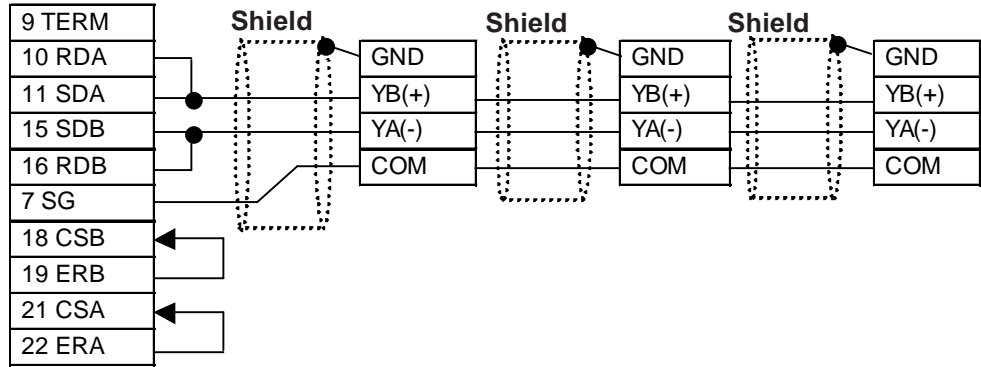

When using Digital's RS-422 connector terminal adapter GP070-CN10-O

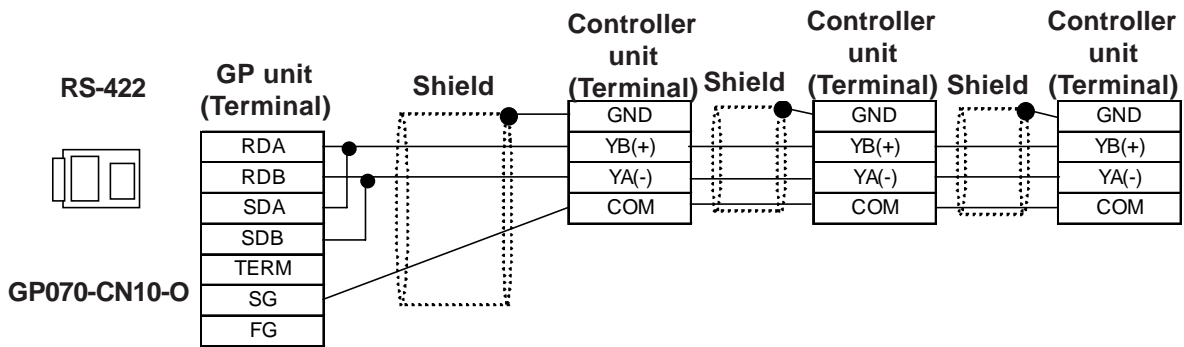

Additional termination resistance is not required, since it is already built into the Controller.

<When using DCL-33A series units>

When using Digital's RS-422 connector terminal adapter GP070-CN10-O

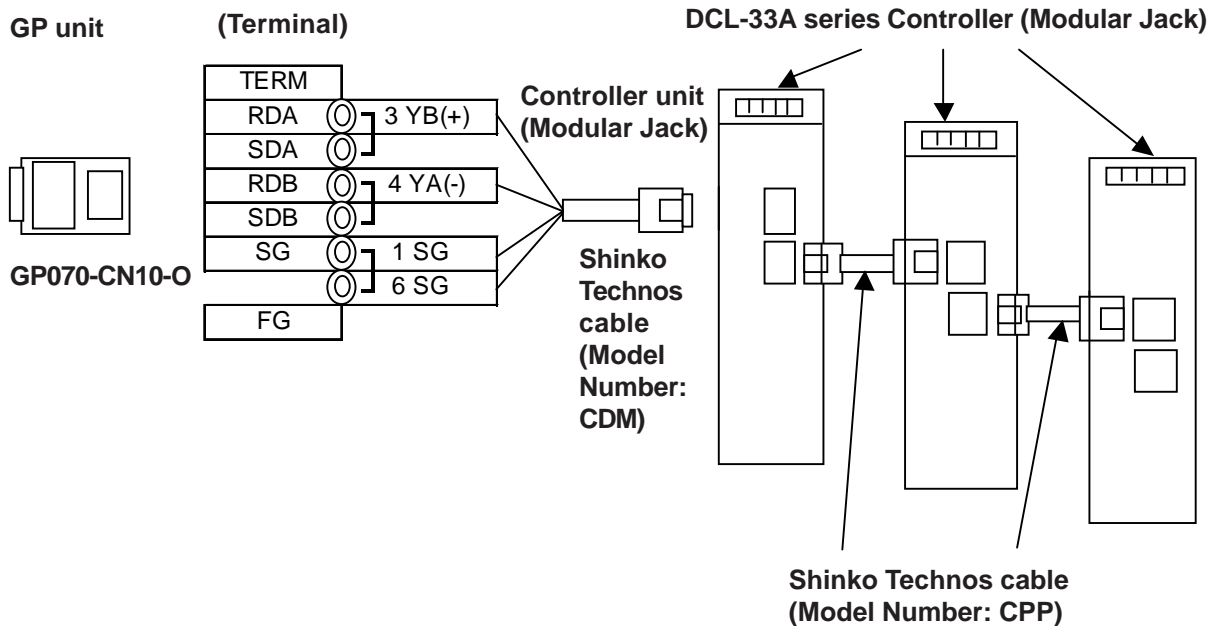

12.6.3 Supported Devices

The following list shows the range of devices supported by the GP/GLC.

■ **C Series**

Device	Bit Addresses*1	Word Addresses*1	
Channel 1	1CH010 ~ 1CH84F	1CH01 ~ 1CH84	H/L
Channel 2	2CH010 ~ 2CH84F	2CH01 ~ 2CH84	
Channel 3	3CH010 ~ 3CH84F	3CH01 ~ 3CH84	
Channel 4	4CH010 ~ 4CH84F	4CH01 ~ 4CH84	
Channel 5	5CH010 ~ 5CH84F	5CH01 ~ 5CH84	
Channel 6	6CH010 ~ 6CH84F	6CH01 ~ 6CH84	
Channel 7	7CH010 ~ 7CH84F	7CH01 ~ 7CH84	
Channel 8	8CH010 ~ 8CH84F	8CH01 ~ 8CH84	
Channel 9	9CH010 ~ 9CH84F	9CH01 ~ 9CH84	
Channel 10	10CH010 ~ 10CH84F	10CH01 ~ 10CH84	
Channel 11	11CH010 ~ 11CH84F	11CH01 ~ 11CH84	
Channel 12	12CH010 ~ 12CH84F	12CH01 ~ 12CH84	
Channel 13	13CH010 ~ 13CH84F	13CH01 ~ 13CH84	
Channel 14	14CH010 ~ 14CH84F	14CH01 ~ 14CH84	
Channel 15	15CH010 ~ 15CH84F	15CH01 ~ 15CH84	
Channel 16	16CH010 ~ 16CH84F	16CH01 ~ 16CH84	
Channel 17	17CH010 ~ 17CH84F	17CH01 ~ 17CH84	
Channel 18	18CH010 ~ 18CH84F	18CH01 ~ 18CH84	
Channel 19	19CH010 ~ 19CH84F	19CH01 ~ 19CH84	
Channel 20	20CH010 ~ 20CH84F	20CH01 ~ 20CH84	

*1 Input all addresses in hexadecimal characters.



- The GP processes all Controller data items in the same way.
- Designating an address means that the data item number specifies the address.

The C Series communication guide's [Communication Command List] includes the following data items for each channel. The C Series supports up to 20 channels.

Command Type	Data Item	Data
20H/50H	0001H : Main setting value (SV) setting	Setting Value
20H/50H	0002H : Main proportional band setting	Setting Value
20H/50H	0003H : Integral time setting	Setting Value
20H/50H	0004H : Derivative time setting	Setting Value
.	:	:

The item Nos. here are the GP addresses.

20H:Read command can be performed.
50H:Write command can be performed.

- When the channel 1 data item is “the setting of main setting value (SV)”, the item No. is “0001H”, and the GP’s address is the following:



- The channel 1 data item “the integrated time setting”, has an item number of “0003H”, and the GP address is “1CH0003”.
- The channel 2 data item “the integrated time setting” has an item number of “0003H”, and the GP address is “2CH0003”.
- When the command type is 20H, data read can be performed. When it is 50H, data write can be performed.

(20H/50H are used to perform read and write.)

■ FC Series

Device	Bit Addresses*1	Word Addresses*1	
Data Item	00010 ~ 0086F	0001 ~ 0086	H/L
Setting Value Memory 1	1S010 ~ 1S86F	1S01 ~ 1S86	
Setting Value Memory 2	2S010 ~ 2S86F	2S01 ~ 2S86	
Setting Value Memory 3	3S010 ~ 3S86F	3S01 ~ 3S86	
Setting Value Memory 4	4S010 ~ 4S86F	4S01 ~ 4S86	
Setting Value Memory 5	5S010 ~ 5S86F	5S01 ~ 5S86	
Setting Value Memory 6	6S010 ~ 6S86F	6S01 ~ 6S86	
Setting Value Memory 7	7S010 ~ 7S86F	7S01 ~ 7S86	

*1 Input all addresses in hexadecimal characters.



- The GP processes all Controller data items in the same way.
- Designating an address means that the data item number specifies the address.

The FC Series communication guide’s [Communication Command List] includes the following data items for each channel. When the command type is 20H, data read can be performed. When it is 50H, data write can be performed. (20H/50H are used to perform read and write.)

Contents	Sub Addresses	Command Classification	Data Items
Main setting value or step temperature setting value	1 to 7	20H/50H	0001H
Setting value memory number or step number selection	0	20H/50H	0002H
PID auto-tuning Performance / Cancellation	0	20H/50H	0003H
Proportional band setting	1 to 7	20H/50H	0004H
:	:	:	:

Sub Addresses (Setting Memory No.)

The item No. here is the GP addresses

When using the FC Series, the sub addresses must be selected. Here, “sub addresses” mean “the setting value memory No.”. For example, “sub address 1” means “setting value memory No.1”. The data items, that the sub addresses are needed to be set, therefore, are needed to be specified the device of “setting value memory*”.

Data items with the sub addresses that do not need to be set (when the sub address is 0), can specify only the number of data items.

E.g. Data items with the sub addresses that do not need to be set.

When setting value memory No.1, GP address data items (the main setting value, “step temperature setting value”) are as follows:

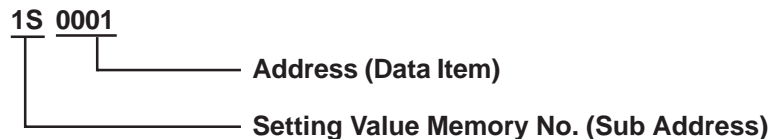

E.g. Data items with the sub addresses that do not need to be set.

GP address data items (the setting value memory number selection, “step numbers”) are as follows:



■ FIR/GC/FCL Series

Device	Bit Addresses ^{*1}	Word Addresses ^{*1}	
Data Item	00010 ~ 00A3F	0001 ~ 00A3	H/L

**1 Input all addresses in hexadecimal characters.*



- The GP processes all Controller data items in the same way.
- Designating an address means that the data item number specifies the address.

The FIR Series communication guide’s [Communication Command List] includes the following data items for each channel. When the command type is 20H, data read can be performed. When it is 50H, data write can be performed. (20H/50H allow read and write to be performed.)

Command Type	Data Item	Data
20H/50H	0001H : Alarm 1 (A1) Setting	Setting Value
20H/50H	0002H : Alarm 2 (A2) Setting	Setting Value
20H/50H	0003H : Alarm 3 (A3) Setting	Setting Value
20H/50H	0004H : Setting Value Lock Designation	Setting Value
:	:	:

The item Nos. here are the GP addresses.
 20H:Read command can be performed.
 50H:Write command can be performed.

- For the data item “Alarm 1 (A1) Setting”, the item number is 0001H. As a result, the GP address is as follows:



- For the data item “Alarm 2 (A2) Setting”, the item number is 0002H. As a result, the GP address is “0002”.

■ PC-900 Series

Device	Bit Addresses	Word Addresses	Remarks	
Data Items	00010 ~ 0400F	0001 ~ 0400	*2	H/L
	04010 ~ 0800F	0401 ~ 0800		
	08010 ~ 0C00F	0801 ~ 0C00		
	0C010 ~ 1000F	0C01 ~ 1000		
	10010 ~ 1400F	1001 ~ 1400		
	14010 ~ 1800F	1401 ~ 1800		
	18010 ~ 1C00F	1801 ~ 1C00		
	1C010 ~ 2000C	1C01 ~ 2000		
	20010 ~ 2400F	2001 ~ 2400		
	24010 ~ 2800F	2401 ~ 2800		
	28010 ~ 2C00F	2801 ~ 2C00		
	2C010 ~ 3000F	2C01 ~ 3000		
	30010 ~ 3400F	3001 ~ 3400		
	34010 ~ 3800F	3401 ~ 3800		
	38010 ~ 3C00F	3801 ~ 3C00		
	3C010 ~ 4000F	3C01 ~ 4000		
	40010 ~ 4400F	4001 ~ 4400		
	44010 ~ 4800F	4401 ~ 4800		
	48010 ~ 4C00F	4801 ~ 4C00		
	4C010 ~ 5000F	4C01 ~ 5000		
	50010 ~ 5400F	5001 ~ 5400		
	54010 ~ 5800F	5401 ~ 5800		
	58010 ~ 5C00F	5801 ~ 5C00		
	5C010 ~ 6000C	5C01 ~ 6000		
	60010 ~ 6400F	6001 ~ 6400		
	64010 ~ 6800F	6401 ~ 6800		
	68010 ~ 6C00F	6801 ~ 6C00		
	6C010 ~ 7000C	6C01 ~ 7000		
	70010 ~ 7400F	7001 ~ 7400		
	74010 ~ 7800F	7401 ~ 7800		
	78010 ~ 7C00F	7801 ~ 7C00		
	7C010 ~ 7991F	7C01 ~ 7991		

*1 Input all addresses in hexadecimal characters.

*2 The data items are internally processed, with each “block” being divided into 1024 words (0x400). Therefore, be aware that the following functions cannot be used with settings that exceed a block (1024 words). Be sure to set the data items to within one block when using this series unit.

1) “a” tag setting

(alarms will not displayed)

2) Block Read - using the 2-way function

(Only the maximum number of addresses in the selected block will be displayed.)



- The GP processes all Controller data items in the same way.
- Designating an address means that the data item number specifies the address.

The PC-900 Series communication guide's [Communication Command List] includes the following data items for each channel. When the command type is 20H, data read can be performed. When it is 50H, data write can be performed. (20H/50H are used to perform read and write.)

Command Classification	Data Item	Data
20H/50H	0001H : Fixed value control / Main setting value setting	Setting Value
20H/50H	0002H : Fixed value control / Control output (OUT 1) proportional band setting	Setting Value
20H/50H	0003H : Fixed value control / Integral time setting	Setting Value
20H/50H	0004H : Fixed value control / Derivative time setting	Setting Value
.	:	:

The item Nos. here are the GP addresses.

20H:Read command can be performed.
50H:Write command can be performed.

For data item “The setting of the main setting value (SV) for the stationary position control”, the item number is 0001H. As a result, the GP address is as follows.

0002

Address (Data Item)

For data item “The setting of the integrated time for the stationary position control”, the item number is 0003H. As a result, the GP address is “0003”.

■ **JCR-33A/JCD-33A/JIR-301-M/DCL-33A Series**

Device	Bit Address ^{*1}	Word Address ^{*1}	Remarks	
Data Items	00010 ~ 00A1F	0001 ~ 00A1		H/L

**1 Input all addresses in hexadecimal characters.*



- The GP processes all Controller data items in the same way.
- Designating an address means that the data item number specifies the address.

The JCR-33A / JCD-33A / JIR-301-M / DCL-33A Series communication guide's [Communication Command List] includes the following data items for each channel. When the command type is 20H, data read can be performed. When it is 50H, data write can be performed (20H/50H allow read and write to be performed). The JIR-301-M, C5 communication guide's [Communication Command List] is explained below as an example.

Command Classification	Data Item	Data
20H/50H	0001H : SV1	Setting Value
20H/50H	0002H : Unused	
20H/50H	0003H : AT Setting	0 : Cancel 1 : Run

The item Nos. here are the GP addresses.
 20H:Read command can be performed.
 50H:Write command can be performed.

■ **PCD-33A Series**

Device	Bit Address ^{*1}	Word Address ^{*1}	Remarks	
Data Items	00020 ~ 00A3F	0002 ~ 00A3		H/L
	11100 ~ 1392F	1110 ~ 1392		
	14100 ~ 1792F	1410 ~ 1792		
	18100 ~ 1992F	1810 ~ 1992		

**1 Input all addresses in hexadecimal characters.*



- The GP processes all Controller data items in the same way.
- Designating an address means that the data item number specifies the address.
- The data items are internally processed, with each “block” being divided into 1024 words (0x400). Therefore, be aware that the following functions cannot be used with settings that exceed a block (1024 words). Be sure to set the data items to within one block when using this series unit.
 - 1) “a” tag setting (Alarms will not be displayed)
 - 2) Block read - using the 2-Way function (For the selected block, addresses upto the maximum address will be displayed)

The PCD-33A Series communication guide’s [Communication Command List] includes the following data items for each channel. When the command type is 20H, data read can be performed. When it is 50H, data write can be performed. (20H/50H allow read and write to be performed.)

Command Classification	Data Item	Data
20H/50H	0001H Unused	
20H/50H	0002H Proportional band setting	Setting Value
20H/50H	0003H Integral time setting	Setting Value
20H/50H	0004H Derivative time setting	Setting Value

The item Nos. here are the GP addresses.
 20H:Read command can be performed.
 50H:Write command can be performed.

For data item details, refer to the following Shinko Technos Corporation communication guides' [Communication Command List].

Series	Guide
C	Multi-Point Temperature Control Unit C Series Guide
FC	FC Series Communication (Option:C,C5) Guide
FIR	FIR Communication Guide
GC	GCS Communication Guide
FCL	FCL Communication Guide
PC-900	PC-935, PC-955 Communication (Option:C,C5,SVTC) Guide
JCR-33A	JCS, R, D-33A(C5) Communication Guide
JCD-33A	
JIR-301-M	JIR-301-M, C5 Communication Guide
DCL-33A	DCL-33A(C5) Communication Guide
PCD-33A	PCD-33A(C5, SVTC) Communication Guide



When the data item's setting value uses a decimal point items, the GP displays a value 10 times larger than the setting value. Also, when writing, be sure to write a value 10 times larger than the setting value.

E.g. In case of the PC-900 Series' control output (OUT1) proportional zone
 Indication of Controllers / Setting Value : 2.5%
 Indication of the GP : 25

Also, refer to each model's communication guide for details (with/without a decimal point) about data item setting value ranges.



When setting Tags in the screen editor software, the Controller communication unit No. can be specified during address input. If a communication unit No. is not indicated, the previously entered communication unit No. is automatically used. (The default value is 1.)

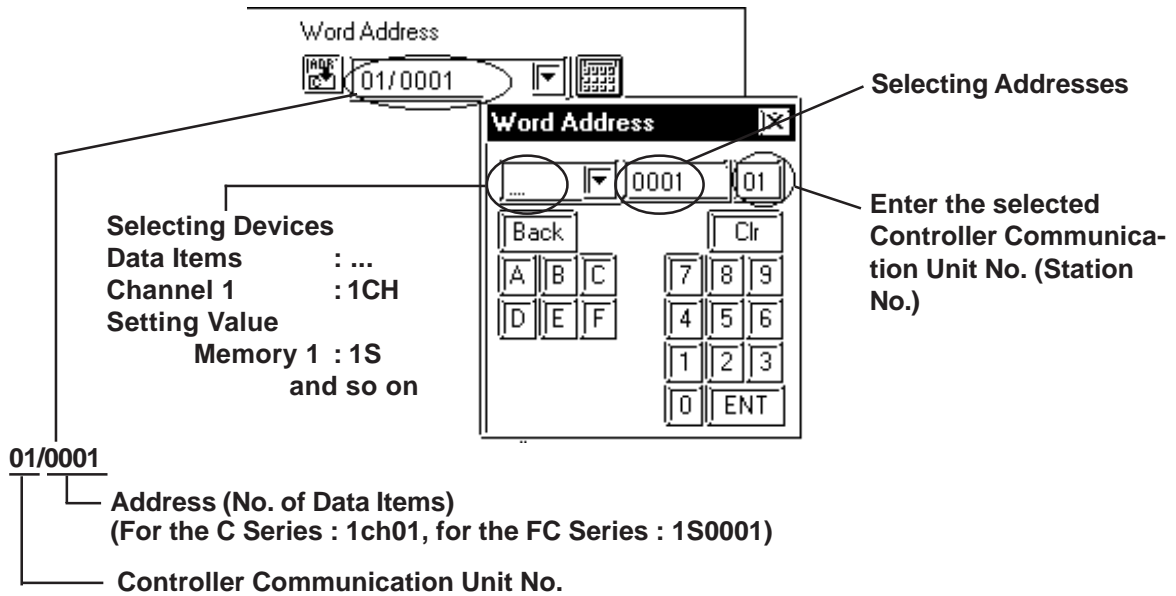

- **GP/GLC's System Area (LS0 to LS19) Settings**
- **The GP/GLC's system area (20 words) cannot be allocated to the Controller's own data area. Even though you can enter the system area settings via the GP's screen editor software or via the GP/GLC's OFFLINE screen, it is impossible to actually allocate the system area to the Controller's data area.**

12.6.4 Environment Setup

The following table lists the recommended Controller and GP/GLC communication settings.

■ **C Series**

GP/GLC Settings		Controller Settings	
Baud Rate	9600 bps	Baud Rate	9600 bps
Data Length	7 bits	-----	-----
Stop Bit	1 bit	-----	-----
Parity Bit	Even	-----	-----
Data Flow control	ER	-----	-----
Communication Format	4 Wires	-----	-----
Unit No.	1	Unit No. ^{*1}	1

**1 It is possible to set a Controller communication unit No. from 0 to 15, however, the GP/GLC can only be set from 1 to 15.*

■ **FC/FIR/GC/FCL/PC-900 Series**

GP/GLC Settings		Controller Settings	
Baud Rate	9600 bps	Baud Rate	9600 bps
Data Length	7 bits	-----	-----
Stop Bit	1 bit	-----	-----
Parity Bit	Even	-----	-----
Data Flow control	ER	-----	-----
Communication Format (using RS-232C)	RS-232C	Communication Format ^{*1}	Serial Communication
Communication Format (using RS-422)	2 wire type	Communication Format ^{*1}	Serial Communication
Unit No.	1	Unit No. ^{*2}	1

**1 PC-900 series only*

**2 It is possible to set a Controller communication unit No. from 0 to 95, however, the GP/GLC can only be set from 1 to 32.*

■ PCD-33A/ JCR-33A/ JCD-33A/ JIR-301-M/ DCL-33A Series

GP/GLC Settings		Controller Settings	
Baud Rate	9600 bps	Baud Rate	9600 bps
Data Length	7 bits	---	---
Stop Bit	1 bit	---	---
Parity Bit	Even	---	---
Data Flow Control	ER	---	---
Communication Format (Using RS-232C)	RS-232C	---	---
Communication Format (Using RS-422)	RS-422 (2-Wire type)	---	---
Unit No.	1 ~ 32	Unit No. *1	1 ~ 32
---	---	Communication Format Selection	nomL (Standard Protocol)

**1 It is possible to set a Controller communication unit No. from 0 to 95, however, the GP/GLC can only be set from 1 to 32.*

12.6.5 Error Code

Controller error codes are represented by the “Host communication error (02:**:##)”, and indicated in the left lower corner of the GP screen.

Error Codes	Meaning
01	Command does not exist
03	Exceeds setting value range
04	Unable to set (during AT execution)
05	Key operation has activated Setting Mode

For more details about the error codes, see

Reference *“The Controller Manual : Communication Guide for each series made by Shinko Technos Corporation”*