

Device/PLC Connection Manuals



About the Device/PLC Connection Manuals

Prior to reading these manuals and setting up your device, be sure to read the "Important: Prior to reading the Device/PLC Connection manual" information. Also, be sure to download the "Preface for Trademark Rights, List of Units Supported, How to Read Manuals and Documentation Conventions" PDF file. Furthermore, be sure to keep all manual-related data in a safe, easy-to-find location.



2.17 Rockwell (Allen-Bradley)

2.17.1 System Structure

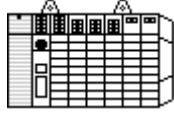

The following describes the system structure for connecting the GP to Rockwell (Allen-Bradley) PLCs.

Reference The Cable Diagrams mentioned in the following tables are listed in the section titled "2.17.2 Cable Diagrams".

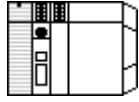

■ SLC 500 Series (using CPU unit Link I/F)

CPU	Cable Diagram	GP
		
SLC-5/03 SLC-5/04	RS-232C (Cable Diagram 1)	GP Series

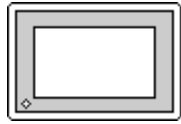
■ PLC-5 Series (using Link I/F)

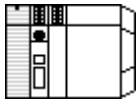

CPU	Link I/F	Cable Diagram	GP
	 DATA HIGHWAY PLUS		
All PLC-5 processors which can connect one of the link unit shown on the right.	1785-KE 1785-KE/C	RS-232C (Cable Diagram 2)	GP Series
	1770-KF2	RS-232C (Cable Diagram 3)	
		RS-422 (Cable Diagram 4)	

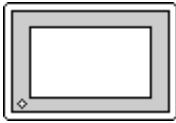
■ **PLC-5 Series (CPU Direct Connection)**

CPU *1	Cables Diagram	GP
		
PLC-5/11 PLC-5/20 PLC-5/30 PLC-5/40 PLC-5/40L PLC-5/60 PLC-5/60L	RS-232C (Cable Diagram 3) RS-422 (Cable Diagram 5)	GP Series

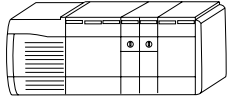

*1 Connect to Channel 0 (CH0).

■ **ControlLogix 5000 Series (using CPU unit Link I/F)**



CPU	Cable Diagram	GP/GLC
		
1756-L1 1756-L1M1 1756-L1M2 1756-L1M3 1756-L55M13 1756-L55M14 1756-L55M16	RS-232C <Cable Diagram 6>	GP Series *1 GLC Series

*1 This PLC can be connected only to GP377 Series units.



■ **MicroLogix 1000 Series (CPU Direct Connection)**

CPU	Link	Cable Diagram	GP
			
1761-L16AWA 1761-L32AWA 1761-L20AWA-5A 1761-L10BWA 1761-L16BWA 1761-L20BWA-5A 1761-L32BWA 1761-L10BWB 1761-L16BWB 1761-L20BWB-5A 1761-L32BWB 1761-L16BBB 1761-L32BBB 1761-L32AAA	RS-232C port on CPU unit	RS-232C <Cable Diagram 7>	GP Series





■ **MicroLogix 1200 Series (CPU Direct Connection)**

CPU	Link	Cable Diagram	GP
			
1762-L24AWA 1762-L24BWA 1762-L24BXB 1762-L40AWA 1762-L40B WA 1762-L40BXB	RS-232C port on CPU unit	RS-232C <Cable Diagram 7>	GP Series





■ **MicroLogix 1200 Series (CPU Direct Connection)**

CPU	Link	Cable Diagram	GP
			
1764-LSP	RS-232C port on Base unit	RS-232C <Cable Diagram 7>	GP Series



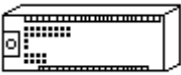

■ **MicroLogix 1000 Series** (using Advanced Interface Converter)

CPU	Link	Cable Diagram	GP
			
1761-L16AWA 1761-L32AWA 1761-L20AWA-5A 1761-L10BWA 1761-L16BWA 1761-L20BWA-5A 1761-L32BWA 1761-L10BWB 1761-L16BWB 1761-L20BWB-5A 1761-L32BWB 1761-L16BBB 1761-L32BBB 1761-L32AAA	Advanced Interface Converter (1761-NET-AIC)	RS-232C <Cable Diagram 8>	GP Series

■ **MicroLogix 1000 Series** (using Advanced Interface Converter)

CPU	Link	Cable Diagram	GP
			
1762-L24AWA 1762-L24BWA 1762-L24BXB 1762-L40AWA 1762-L40BWA 1762-L40BXB	Advanced Interface Converter (1761-NET-AIC)	RS-232C <Cable Diagram 8>	GP Series

■ **MicroLogix 1500 Series** (using Advanced Interface Converter)

CPU	Link	Cable Diagram	GP
			
1764-LSP	Advanced Interface Converter (1761-NET-AIC)	RS-232C <Cable Diagram 8>	GP Series

2.17.2 Cable Diagrams

The cable diagrams illustrated below and the cable diagrams recommended by Rockwell (Allen-Bradley) may differ; however, using these cables for your PLC operations will not cause any problems.



Ground your PLC's FG terminal according to your country's applicable standard. For details, refer to the corresponding PLC manual.



- **Connect the FG line of the Shield cable to either the GP or PLC, depending on your environment. When using a connector hood and grounding the FG line, be sure to use an electrical conductor.**
- **For the RS-232C connection, use a cable length less than 15m.**
- **If a communications cable is used, it must be connected to the SG (signal ground).**
- **For the RS-422 connection, refer to Rockwell's PLC manual for the cable length.**

Cable Diagram 1 (RS-232C)

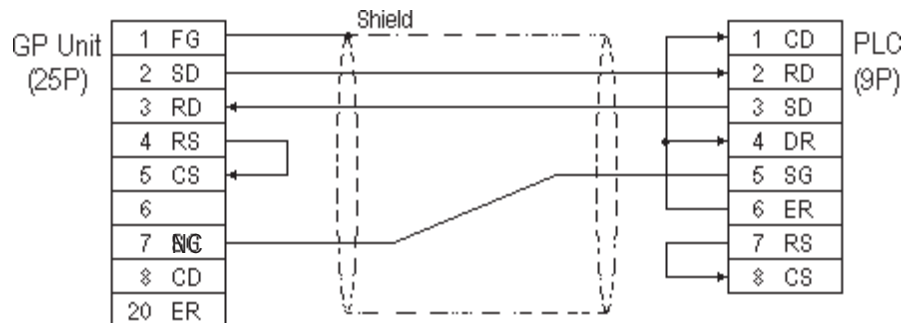

Cable Diagram 2 (RS-232C)

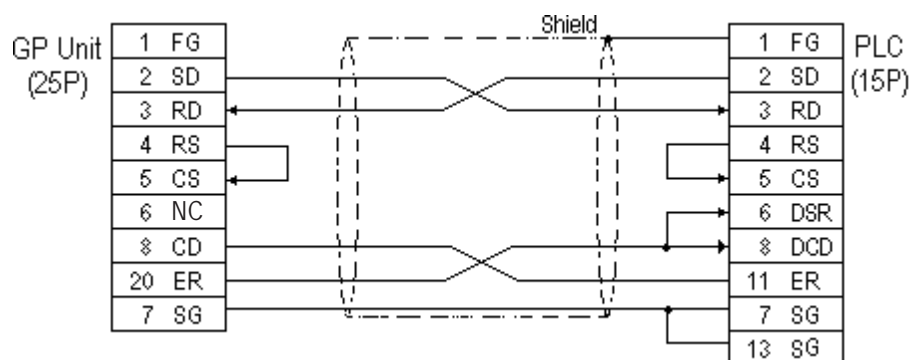

Cable Diagram 3 (RS-232C)

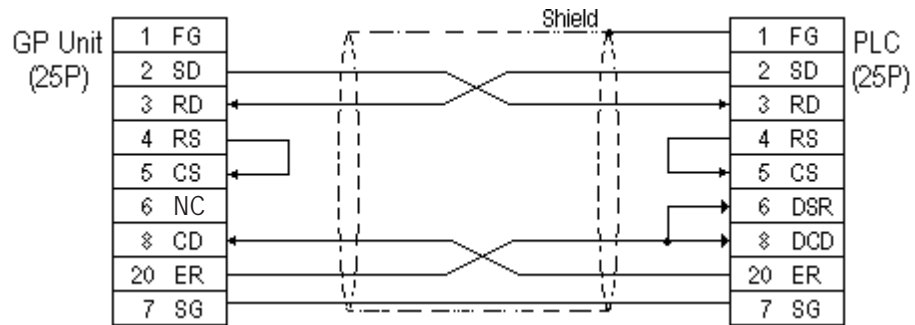

Cable Diagram 4 (RS-422)

- When using Digital's RS-422 connector terminal adapter, GP070-CN10-0

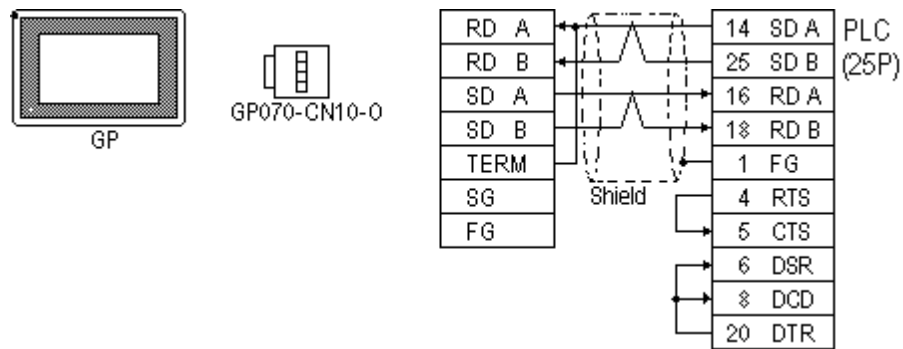

- When using Digital's RS-422 Cable, GP230-IS11-0

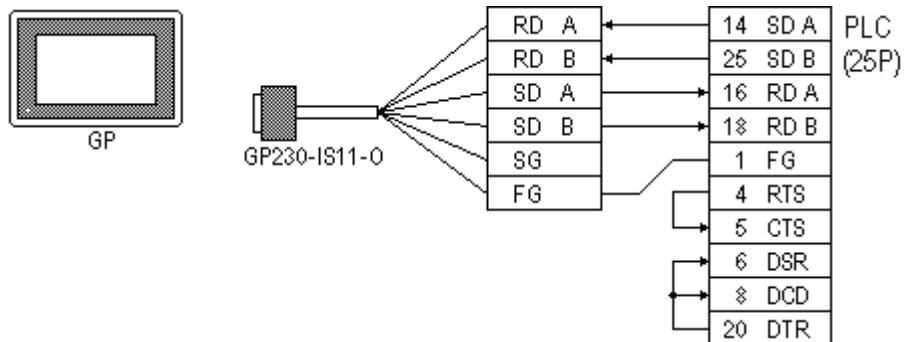

- When making your own cable connections

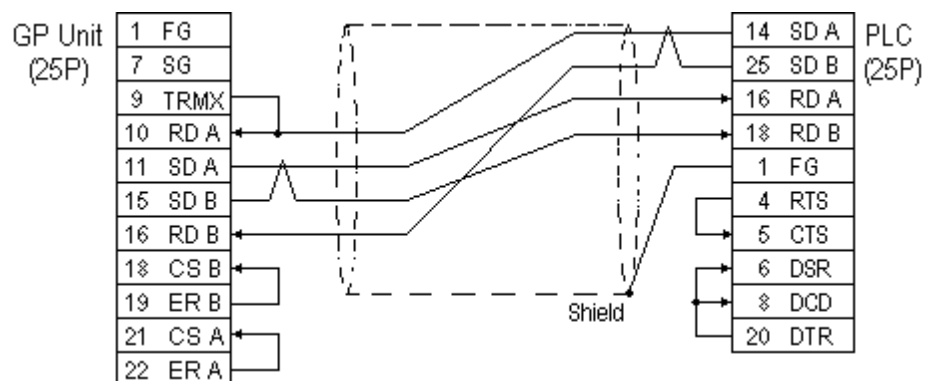



When connecting the #9 and #10 pins in the GP Serial I/F, a termination resistance of 100Ω is added between RDA and RDB.

Cable Diagram 5 (RS-422)

- When using Digital's RS-422 connector terminal adapter, GP070-CN10-0

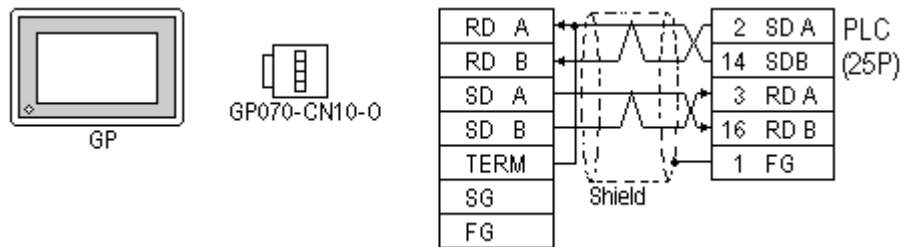

- When using Digital's RS-422 Cable, GP230-IS11-0

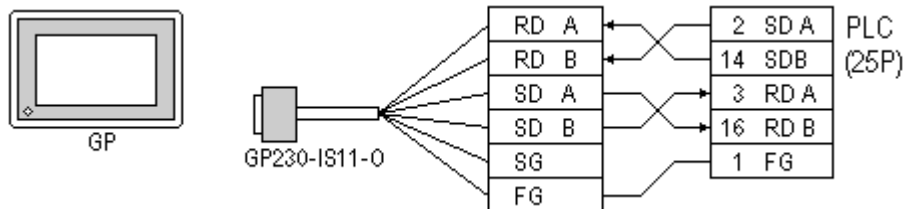

- When making your own cable connections

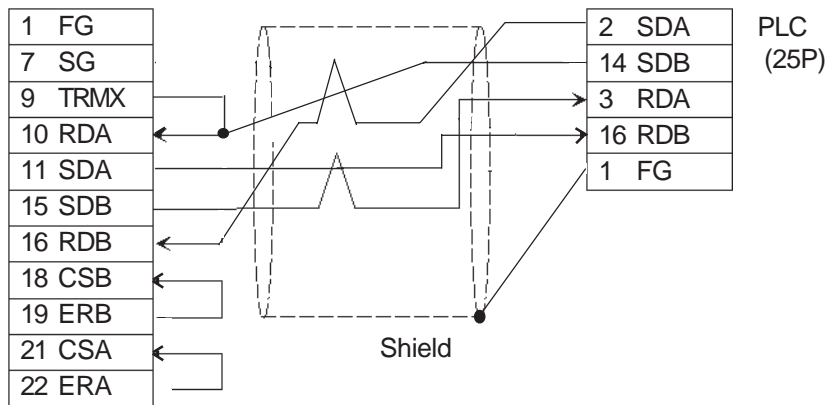

When connecting the #9 and #10 pins in the GP Serial I/F, a termination resistance of 100Ω is added between RDA and RDB.

Cable Diagram 6 (RS-232C)

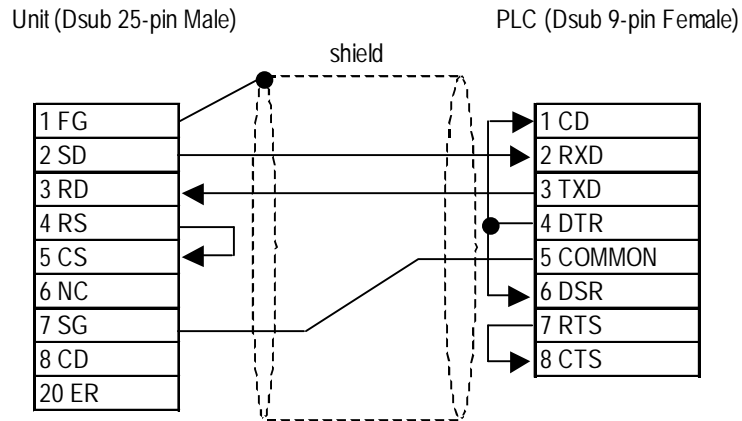

- Note:**
- Connect the shield to the GP's FG terminal.
 - If a communications cable is used, it must be connected to the SG terminal and COMMON terminal.

Cable Diagram 7 (RS-232C)

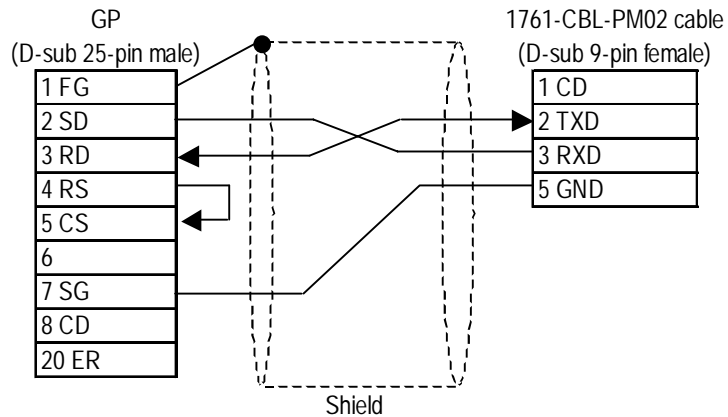

Cable Diagram 8 (RS-232C)

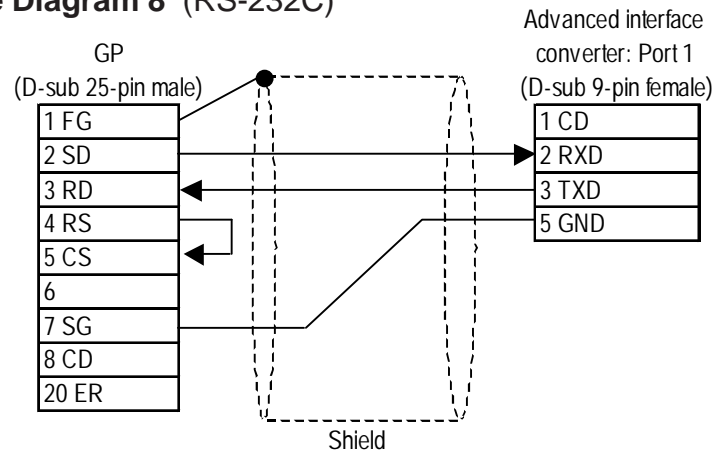

2.17.3 Supported Devices

The following describes the range of devices supported by the GP.

■ SLC 500/MicroLogix 1000•1200•1500 Series

 Setup System Area here.

Device	Bit Address	Word Address	Particulars
Bit	B3:000/00 ~ B3:255/15	B3:000 ~ B3:255	H/L
	B9:000/00 ~ B255:255/15	B9:000 ~ B255:255	
Timer (TT: Timing Bit)	T4:000/TT ~ T4:255/TT	---	
	T9:000/TT ~ T255:255/TT		
Timer (DN: Completion Bit)	T4:000/DN ~ T4:255/DN	---	
	T9:000/DN ~ T255:255/DN		
Timer (PRE: Setup Value)	---	T4:000.PRE ~ T4:255.PRE	*1
		T9:000.PRE ~ T255:255.PRE	
Timer (ACC: Current Value)	---	T4:000.ACC ~ T4:255.ACC	*1
		T9:000.ACC ~ T255:255.ACC	
Counter (CU: Up Count)	C5:000/CU ~ C5:255/CU	---	L/H
	C9:000/CU ~ C255:255/CU		
Counter (DC: Down Count)	C5:000/CD ~ C5:255/CD	---	
	C9:000/CD ~ C255:255/CD		
Counter (CN: Completion Bit)	C5:000/DN ~ C5:255/DN	---	
	C9:000/DN ~ C255:255/DN		
Counter (PRE: Setup Value)	---	C5:000.PRE ~ C5:255.PRE	*1
		C9:000.PRE ~ C255:255.PRE	
Counter (ACC: Current Value)	---	C5:000.ACC ~ C5:255.ACC	*1
		C9:000.ACC0 ~ C255:255.ACC	
Integer	---	N7:000 ~ N7:255	 H/L
		N9:000 ~ N255:255	
Floating point	---	F8:000 ~ F255:255	L/H

*1 When reading and writing consecutive addresses that are all two words or longer, reading will take longer than for other devices, and the overall screen refresh speed will be slower.



- The range of available devices depends on the type of CPU used. For available device range information, refer to your PLC's manual.
- In the above tables, the address descriptions and input methods used in GP-PRO/PBIII for Windows V6.0 or earlier software may vary, however the internal data can be converted. Even if GP-PRO/PBIII for Windows V6.0 or later software is used, the internal data will not be damaged.
- When using Version 6.0 or earlier address displays and input methods with Versions 6.1 or later software, be sure to use the following steps.
 - 1) Locate and open the folder named [SLC500] in your GP/PRO/PBIII for Windows Version 6.1 or later CD-ROM.
 - 2) Copy the file named [SLC500.TBL] to the folder [PLCTBL] on your PC's hard disk drive. (This folder was created when Version 6.1 was installed.)
 - 3) Delete the [SLC500.PTO] from the folder [PTO] was created when GP-PRO/PBIII was installed.
 - 4) Start up GP-PRO/PBIII for Windows. You will now be able to use Version 6.0 or earlier address displays and input methods. When running screen editor software version 6.0 or earlier, D-Script creation or screen data modification while using [SLC500.PTO] is not possible.
- File Numbers 0~8 are the User's default files.
- A PLC COM Error (02:10) develops when a device cannot be allocated into the PLC data table map.
- According to the PLC specifications, the input and output relays cannot perform direct reads and writes. As a result, perform the following procedures via the PLC:

When reading data; use a ladder program to move the input and output relay data either as bits or as integers, and then read out those bits or integers.

When writing data; write the data as either bits or integers, and then use the ladder program to move the data to the input or output relays.
- In Rockwell (Allen-Bradley) PLCs, the structure of each device's data is determined from the Element; however, in GP-PRO/PBIII for Windows there is no Element. Therefore, use the following examples when entering device data.

- For word devices N, B, and F

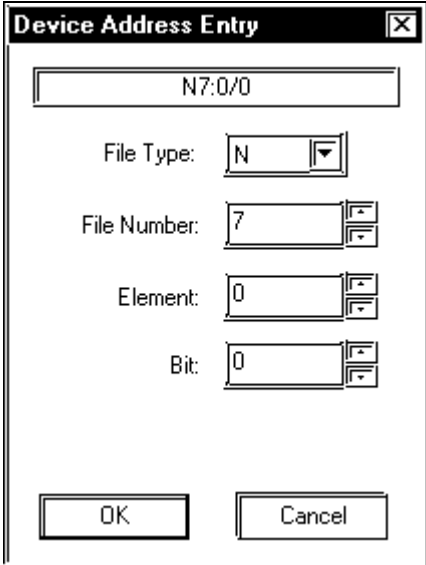

Display after input: N7:0

- For word devices T and C

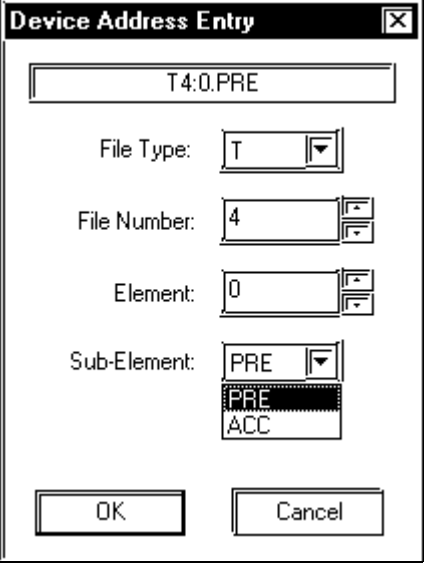

Display after input: T4:0.PRE

- For bit devices T and C

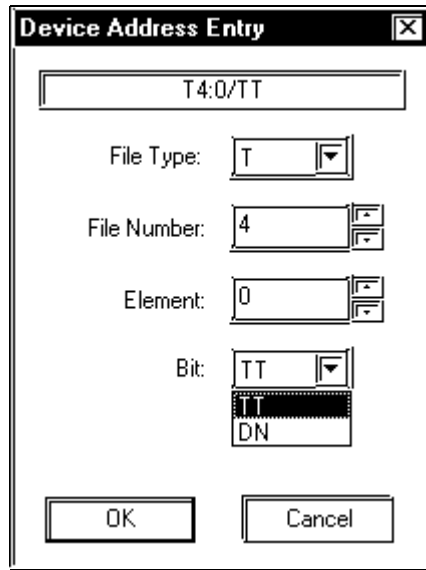



The image shows a dialog box titled "Device Address Entry" with a close button (X) in the top right corner. The dialog contains a text field at the top with the text "T4:0/TT". Below this are four rows of controls: "File Type:" with a dropdown menu showing "T"; "File Number:" with a text box containing "4" and a spinner control; "Element:" with a text box containing "0" and a spinner control; and "Bit:" with a dropdown menu showing "TT" and a list box containing "TT" and "DN". At the bottom of the dialog are two buttons: "OK" and "Cancel".

Display after input: T4:0/TT

■ PLC-5 Series

 Setup System Area here.

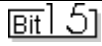
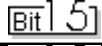
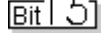
Device	Bit Address	Word Address	Particulars	
Input Relay	I00000 ~ I27717	I000 ~ I277		H/L
Output Relay	O00000 ~ O27717	O000 ~ O277		
Internal Relay	B300000 ~ B6799915	B3000 ~ B67999		
Timer (TT: Timing Bit)	TT3000 ~ TT67999	---		L/H
Timer (TD: Complete Bit)	TD3000 ~ TD67999	---		
Counter (CC: Count)	CC3000 ~ CC67999	---		
Counter (CD: Complete Bit)	CD3000 ~ CD67999	---		
Timer (ACC: Current Value)	---	TA3000 ~ TA67999		
Timer (PRE: Setup Value)	---	TP3000 ~ TP67999		
Counter (ACC: Current Value)	---	CA3000 ~ CA67999		
Counter (PRE: Setup Value)	---	CP3000 ~ CP67999		
Data Register Integer	---	N3000 ~ N67999		H/L
Data Register BCD	---	D3000 ~ D67999		
Data Register ASCII	---	A3000 ~ A67999		



- The range of supported devices may be different depending on your CPU.
- In Rockwell (Allen-Bradley) PLCs, the structure of each device data is determined from the *Element*; in GP-PRO/PBIII for Windows there is no concept called the *Element*. Use the following examples when entering device data.

PLC Data

■ When Using Elements

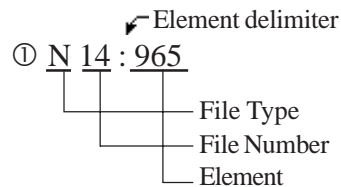

GP-PRO/PBIII Input

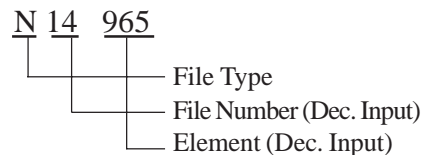

PLC Side

GP-PRO/PBIII Input

■ *When Using Words*

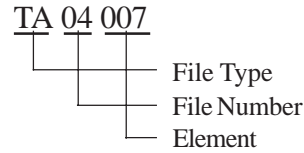
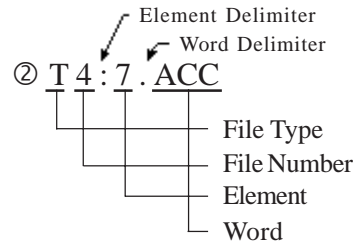

■ *When Using Bits*

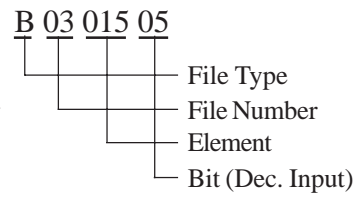
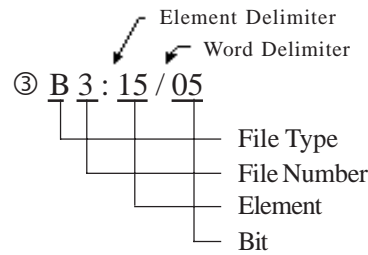

B301505 represents the same data as B3/245 (number 245 bits of file number 3). However, GP-PRO/PBIII for Windows cannot be used to input B3/245 directly.

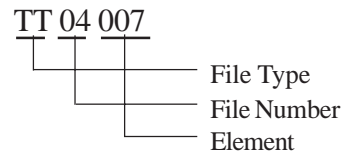
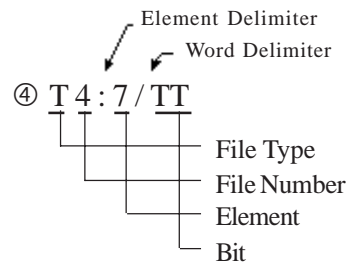

- **There is no File Number for the *Input Relay* and *Output Relay*. Also, the Element and Bit Numbers are Hexadecimal.**



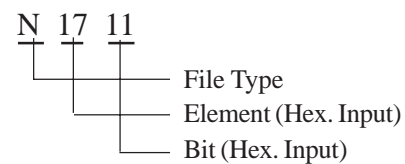
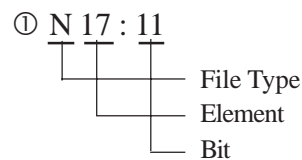

PLC Side

GP-PRO/PBIII Input



■ ControlLogix 5000 Series

 Setup System Area here.

Device	Bit Address	Word Address	Particulars	
Bit (BOOL)	BOOL00000000-BOOL99999931	BOOL000000-BOOL999999	*1*3	L/H
8 bit integer (SINT)	_____	SINT000000-SINT999998	  *1	
16 bit integer (INT)	_____	INT000000-INT999999	 *1	
32 bit integer (DINT)	_____	DINT000000-DINT999999	 *1	
32 bit float (REAL)	_____	REAL000000-REAL999999	*1*2	H/L

***1** When using a GP Series unit to access a ControlLogix 5000 Series unit's data memory, you must first allocate data memory's array elements. When allocating array elements, use File numbers and Element numbers. An address designation example is shown below for GP-PRO/PBIII for Windows.

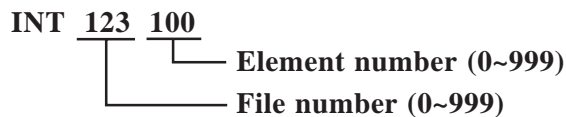

***2** This device uses Float. When this type of device is used, only the E-tag and K-tag's "32-bit Float" setting can be used.

***3** The BOOL device descriptions used in the GP-PRO/PBIII manual and the RSLogix 5000 manual are different. Please be aware of these differences when setting up BOOL devices.

GP-PRO/PBIII manual	000000 00~ 000000 31	000001 00~ 000001 31	000002 00~ 000002 31	~	000999 00~ 000999 31
RSLogix 5000 manual	0~31	32~63	64~95	~	31968~31999



When using the GP to access a PLC device, be sure to first allocate all Tags used by PLC Data Memory to their respective devices. Use the Rockwell's RSLogix 5000 ladder logic software to allocate these devices.

If device allocation is not performed, a Host Communication Error will occur (02:D6).

Reference  2.17.5 Error Codes

Device Setting Example

The following explanation is for the ControlLogix 5000 device allocation.

1) PLC Tag Settings

Designate the Tag Name and Type.

- Tag Name : Can be set to any value. (Not related to GP device name)
- Type : Use one of the following data types for the Element setting.
(Use the same device name as the GP)

BOOL (32-bit data type)

INT (word data type)

DINT (dword data type)

SINT (byte data type)

REAL (float data type)

Example 1

Tag Name	Type
N7	INT[200]
DINT1	DINT[100]
DATA2	SINT[50]

This example’s data uses the following values.

- Row1 : Tag Name “N7” uses the INT data type for a 200 element array.
- Row2 : Tag Name “DINT1” uses the DINT data type for a 100 element array.
- Row3 : Tag Name “DATA2” uses the SINT data type for a 50 element array.

Be sure to set the number of array elements within the GP unit’s maximum usable range. (The GP can access up to 999 elements.)

Also, if array elements are not designated, only one element can be used.

Ex. Tag Name:N8, Type:INT allows only one word to be used by N8.

2) Mapping Settings

The tag name set in 1) can have any desired file number allocated to it. It is not possible to set the same file number to two tag names.

Example 2

File Number	Tag Number
2	DATA2
1	DINT1
7	N7

2.17.4 Environment Setup

The following tables list Digital's recommended PLC and GP communication settings.

■ SLC 500 Series

GP Setup		Special Interface Module Setup	
Baud Rate	19200 bps	Baud Rate	19200 bps
Data Length	8 bits (fixed)	---	
Stop Bit	1 bit (fixed)	---	
Parity Bit	EVEN	Parity Bit	EVEN
Data Flow Control	ER Control	---	
Communication Format	RS-232C	---	
---		Communication Driver	DF1 HALF-DUPLEX SLAVE ^{*1}
---		Duplicate Packet Detection	DISABLE ^{*1}
---		Error Detection	BCC ^{*1}
---		Control Line	No Handshaking ^{*1}
Unit No. (DH GP) ^{*2}	0	Station Address ^{*2}	0

* 1 Will not operate with any other settings.

* 2 Setup the Station Address and the GP's Unit No. (DH GP) address to the same value (address set as decimal values). It is unnecessary to setup the DH PLC address.

Reference Specifying DH addresses

■ PLC-5 Series

GP Setup		CPU (CH0), 1785-KE, 1770-KF2	
Baud Rate	19200 bps	Baud Rate	19200 bps
Data Length	8 bits (fixed)	Data Length	8 bits (fixed)
Stop Bit	1 bit (fixed)	Stop Bit	1 bit (fixed)
Parity Bit	EVEN	Parity Bit	EVEN
Data Flow Control	ER Control	---	
Communication Format (RS-232C)	RS-232C	Communication Format (RS-232C)	RS-232C
Communication Format (RS-422)	4-wire type	Communication Format (RS-422)	RS-422A
---		Comm. protocol	Half duplex (DF1 Slave for CH0) ^{*1}
---		Duplicate Detect	OFF ^{*1}
---		Error Check	BCC ^{*1}
---		Control Line	NO HANDSHAKING ^{*1}
---		Other CH0 Parameters	50
---		DF1 retries	3
---		Diag file	0 (unused file)
---		RTS send delay	0
---		RTS off delay	0
---		Network link ^{*2}	Data Highway Plus
Unit No. (DH GP) ^{*3}	0	Station Address ^{*4*5} (1785-KE, 1770-KF2 side)	0
Unit No. (DH PLC) ^{*3}	1	Station Address ^{*4} (CPU side)	1

**1 Will not operate with any other settings.*

**2 This is the KF2 setup*

**3 Set the DH GP to station address 1785-KE or 1770-KF2, and set the DH PLC's to the CPU's station address. When using the 1785-KE or 1770-KF2, enter different numbers for the DH GP and DH PLC addresses. With a direct CPU connection, enter the same values in the DH GP and DH PLC addresses. With the GP in Offline Mode, use the "Operating Environment Setup" area to enter the DH address (DH, GP, DH, PLC) base 10 (decimal) values.*

Reference Specifying DH addresses

**4 When using the programming unit, make sure the Terminal Address (programming equipment address) and the Station Address do not overlap.*

**5 Unavailable for CPU Direct Connection.*



When using CH0, setup the CPU to Slave. Do not setup as Point to Point.

■ ControlLogix 5000 Series

GP Setup		PLC Setup	
Baud Rate	19200 bps	Baud Rate ^{*1}	19200 bps
Data Length	8 bit	Data Bits ^{*1}	8 bit
Stop Bit	1 bit	Stop Bit ^{*1}	1 bit
Parity Bit	Even	Parity ^{*1}	Even
Data Flow Control	ER	_____	_____
Communication Format	RS-232C	_____	_____
Unit No.	0	Station Address ^{*2}	0
_____		Mode ^{*1}	System
_____		Control Line ^{*1}	No Handshake
_____		RTS Send Delay ^{*1}	0
_____		RTS Off Delay ^{*1}	0
_____		Protocol ^{*2}	DF1 Slave
_____		Transmit Retries ^{*2}	3
_____		Slave Poll Timeout ^{*2}	3000
_____		EOT Suppression ^{*2}	No Check
_____		Error Detection ^{*2}	BCC
_____		Enable Duplicate Detection ^{*2}	No Check (Disable)

**1 Set via the Rockwell Ladder Logic Software RSLogix 5000 "Serial Port" menu.*

**2 Set via the Rockwell Ladder Logic Software RSLogix 5000 "System Protocol" menu.*

■ MicroLogix 1000 Series (CPU Direct Connection)

GP Setup		PLC Setup	
Baud Rate	19200 bps	Baud Rate	19200 bps
Data Length	8 bits	_____	_____
Stop Bit	1 bit	_____	_____
Parity Bit	Non	Parity	Non
Control Method	ER Control	_____	_____
Communication Format	RS-232C	_____	_____
	RS-422 (4-wire type)	_____	_____
DH Address GP DH Address PLC ^{*1}	0 to 254	Node Address	0 to 254
_____		Driver	DF1 Half Duplex Slave
_____		Control Line	No Handshaking
_____		Error Detection	BCC
_____		EOT Suppression	No Check
_____		Duplicate Packet Detect	No Check
_____		Poll Timeout	3000
_____		Message Retries	3
_____		Pre Transmit Delay	0

**1 Specify the same address for DH Address GP and DH Address PLC.*

■ MicroLogix 1200/1500 Series (CPU Direct Connection)

GP Setup		PLC Setup	
Baud Rate	19200 bps	Baud Rate	19200 bps
Data Length	8 bits	_____	_____
Stop Bit	1 bit	_____	_____
Parity Bit	Even	Parity	non
Control Method	ER Control	_____	_____
Communication Format	RS-232C	_____	_____
	RS-422 (4-wire type)	_____	_____
DH Address GP DH Address PLC *1	0 to 254	Node Address	0 to 254
Communication Format	RS-232C	_____	_____
_____		Driver	DF1 Half Duplex Slave
_____		Control Line	No Handshaking
_____		Error Detection	BCC
_____		EOT Suppression	OFF
_____		Duplicate Packet Detect	OFF
_____		Poll Timeout	3000
_____		Message Retris	3
_____		Pre Transmit Delay	0

**1 Specify the same address for DH Address GP and DH Address PLC.*

■ MicroLogix 1000/1200/1500 Series (Using Advanced Interface Converter)

GP Setup		PLC Setup	
Baud Rate	19200 bps	Baud Rate	Auto
Data Length	8 bits	_____	_____
Stop Bit	1 bit	_____	_____
Parity Bit	Non	_____	_____
Control Method	ER Control	_____	_____
Communication Format	RS-232C	_____	_____
	RS-422 (4-wire type)	_____	_____
DH Address GP DH Address PLC *1	0 to 254	_____	_____

**1 Specify the same address for DH Address GP and DH Address PLC.*

■ Specifying DH addresses

Set up the operating environment at the initial setup when the GP is in the OFFLINE mode.

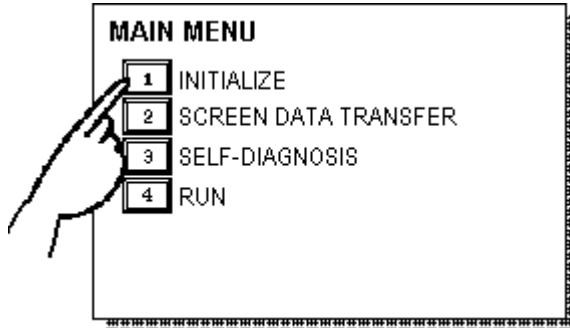

- ① Touch item #1, INITIALIZE. The INITIALIZE menu will appear.

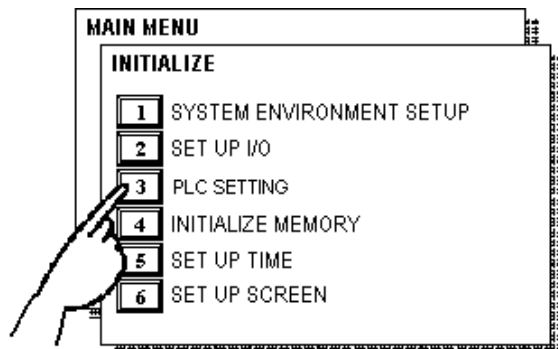

- ② Touch item #3, PLC SETTING. The PLC SETTING menu will appear.

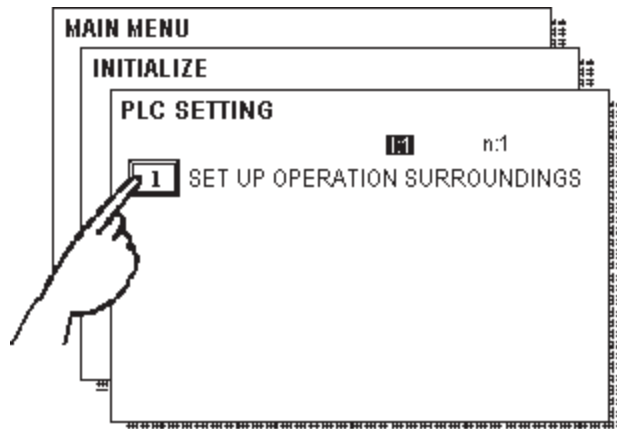

- ③ Touch selection [1:1] and then item #1, SET UP OPERATION SURROUNDINGS. The selected option is then highlighted.

SET UP OPERATION SURROUNDINGS		SET	CANCEL
SYSTEM DATA AREA	START FILE	[]	
	START ADDRESS	[]	
DH ADDRESS (DECIMAL)	GP	[]	
	PLC	[]	
SYSTEM AREA	READING AREA SIZE (0-256)	[]	

- ④ Specify the DH addresses.

2.17.5 Error Codes

■ PLC Error Codes

Controller error codes are represented by the "Host communication error (02:**)", and indicated in the left lower corner of the GP screen. (** stands for an error code.)

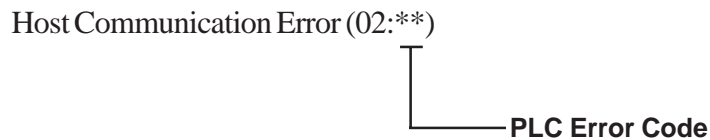

- * There are two types of PLC error codes - STS and EXT STS.

EXT STS error codes have the characters "0xD0" attached to them, to prevent them from overlapping with STS error codes. Thus, all error codes with the last characters of "0xCF" or earlier are STS error codes.

Ex.

When a (02:D2) Host Communication Error occurs, it becomes the EXT STS error code of "0x02".

When a (02:C0) Host Communication Error occurs, it becomes the STS error code of "0xC0".