

Device/PLC Connection Manuals





About the Device/PLC Connection Manuals

Prior to reading these manuals and setting up your device, be sure to read the "Important: Prior to reading the Device/PLC Connection manual" information. Also, be sure to download the "Preface for Trademark Rights, List of Units Supported, How to Read Manuals and Documentation Conventions" PDF file. Furthermore, be sure to keep all manual-related data in a safe, easy-to-find location.

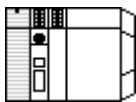

6.3 Modicon

6.3.1 System Structure

■ **Modicon Modbus (GP Slave)**

Host	Cable Diagram	GP
		
Modbus Master	RS-232C (Cable Diagram 1) RS-422 (Cable Diagram 2)	GP Series (Slave)

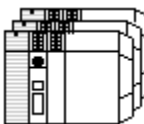
■ **Modicon Modbus Plus (CPU Direct Connection)**

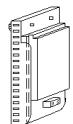
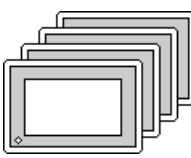
CPU	Cable Diagram	Unit	GP
		 Modbus Plus Module	
884, 984A, 984B	Modbus Plus cable	QPI-MBP-201 (TCP's) ^{*1} QPJ-MBP-201 (TCP's) ^{*1}	Large Size GPs ^{*2} Medium Size GPs ^{*3}

**1 Product manufactured by Total Control Products, Inc.*

**2 The GP/GLC series applicable listed below:*

Series Name	Product Name	Product Name
GP70 Series	GP-470 Series	GP-470E
	GP-570 Series	GP-570S
		GP-570T
		GP-57JS
		GP-570VM
	GP-571 Series	GP-571T
	GP-675 Series	GP-675S
GP-675T		
GP-870 Series	GP-870VM	
GP77R Series	GP-477R Series	GP-477RE
	GP-577R Series	GP-577RS
		GP-577RT
GP2000 Series ^{*1}	GP-2500 Series	GP-2500L
		GP-2500S
		GP-2500T
	GP-2501 Series	GP-2501L
		GP-2501S
		GP-2501T
	GP-2600 Series	GP-2600T
	GP-2601 Series	GP-2601T

**1 When using GP2000/GLC2000 series units, a bus conversion unit (PSL-CONV00) is required.*

*3 The GP/GLC series applicable for CC-Link Intelligent Device Station listed below:

Series Name		Product Name
GP70 Series	GP-377 Series	GP-377L
		GP-377S
GP77R Series	GP-377R Series	GP377RT
	GP-477R Series	GP-477RE
	GP-577R Series	GP-577RS
		GP-577RT

6.3.2 Cable Diagrams

Cable Diagram 1 (RS-232C)

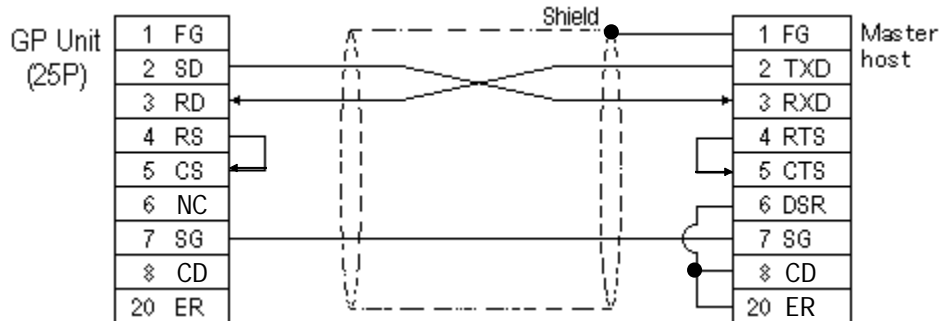

Cable Diagram 2 (RS-422)

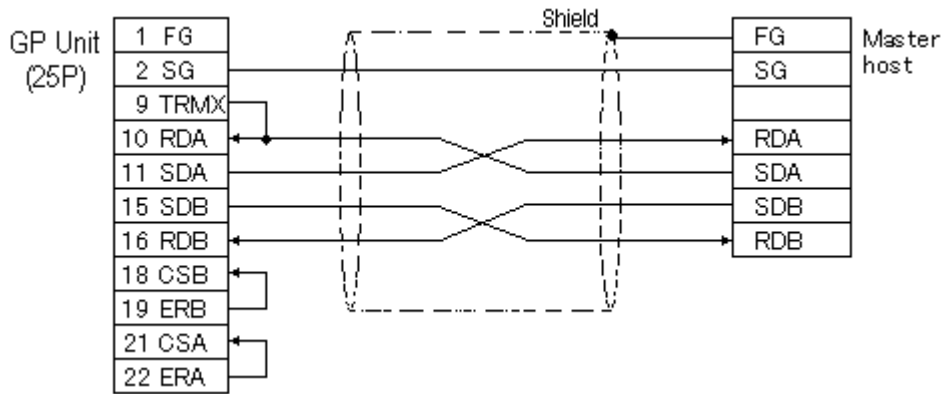

- When using Digital's RS-422 connector terminal adapter GP070-CN10-0

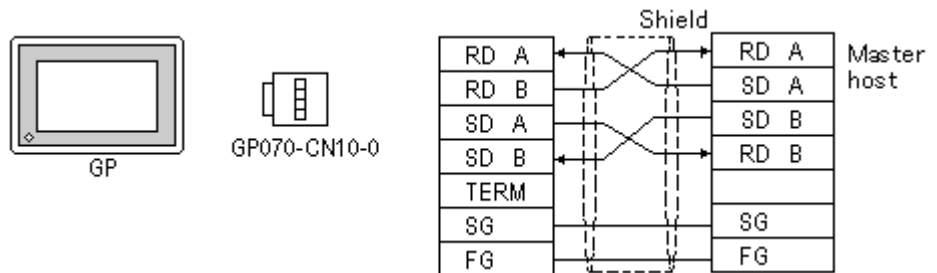

- When using Digital's RS-422 Cable, GP230-IS11-0

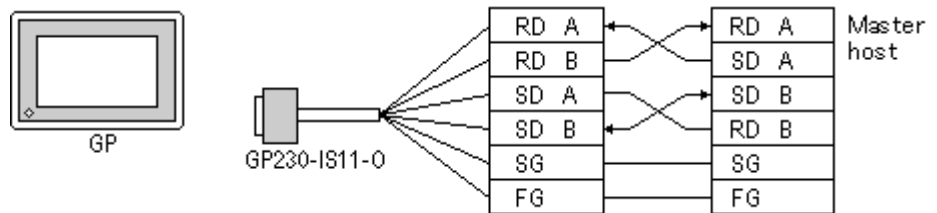

Note: Wiring varies depending on types of master host.

Modbus Slave Diagram

The drawing shows how a GP might be connected as a slave device.

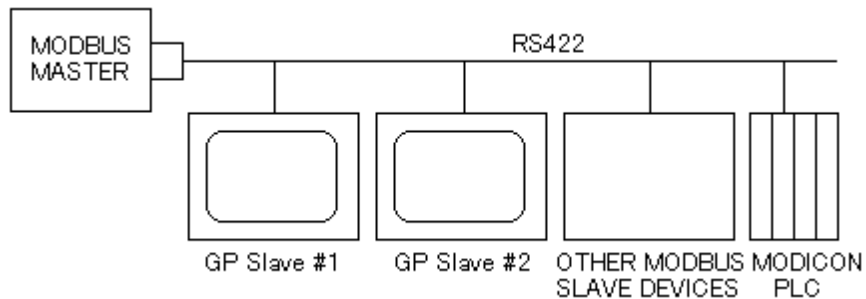

Sample Network (Modbus Plus)

Each node has an LED indicator that flashes patterns to show its status on the network. A simple network consists of two or more nodes connected to a single section.

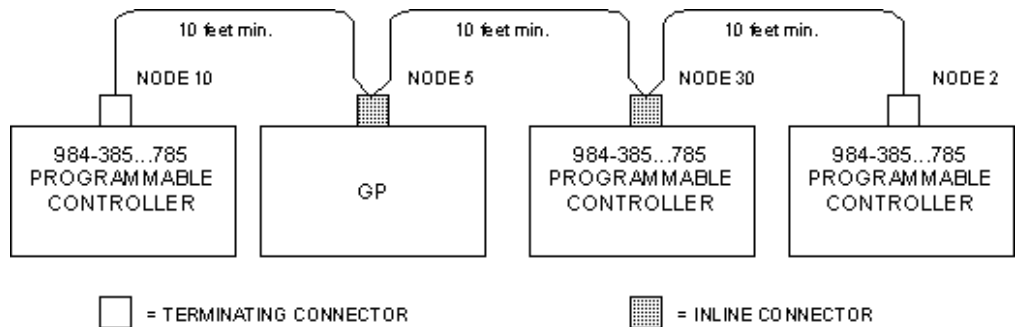

6.3.3 Supported Devices

■ **Modicon Modbus (GP Slave)** Setup System Area here.

Device	Bit Address	Word Address	Particulars
Output Register	---	40001 ~ 49999	L/H

■ **Modicon Modbus Plus** Setup System Area here.

Device	Bit Address	Word Address	Particulars
Output Bit	00001 ~ 08192	---	*1
Input Bit	10001 ~ 18192	---	*1*2
Output Relay	---	40001 ~ 49999	L/H
Input Register	---	30001 ~ 39999	*2

*1 Can also specify a word (16 bit data).

*2 Cannot perform data write.

6.3.4 Environment Setup

Modicon Modbus (GP Slave)

GP Setup		COM Port	
Baud Rate	19200 bps	Baud Rate	19200 bps
Data Length	8 bits	Data Length	RTV (8 bits)
Stop Bit	1 bit	Stop Bit	1 bit
Parity Bit	Even	Parity Bit	EVEN
Data Flow Control	ER	Data Flow Control	ER
Communication Format (RS-232C)	RS-232C	Communication Format (RS-232C)	RS-232C
Communication Format (RS-422)	RS422	Communication Format (RS-422)	RS422
Unit No.	1	Unit No. ^{*1}	1

**1 Unit No. shows the number of the GP itself.*

Modicon Modbus Plus

GP Setup		COM Port	
Baud Rate	---	---	---
Data Length	---	---	---
Stop Bit	---	---	---
Parity Bit	---	---	---
Data Flow Control	---	---	---
Communication Format (RS-232C)	---	---	---
Communication Format (RS-422)	---	---	---
Unit No.	---	---	---
Station Address ^{*1}	1	---	---
Route Selection ^{*2}	1	Station Address	2

** 1 Set the station address with the Dip Switch for Modbus Plus module (QPI-MBP-201/QPJ-MBP-201).*

** 2 Route Selection can be made via the GP-PRO/PBIII System Settings area's "Option" menu.*



- **Operation Environment settings cannot be set using the GP's OFFLINE mode. Be sure to use the GP-PRO/PBIII [System Setup] area to do this.**
- **E and K-tags cannot use the "Indirect" Setting.**
- **After the H-tag starts (is triggered), data cannot be read (out).**
- **After the S-tag starts (is triggered), data cannot be read (out).**
- **The Trend graph's group data display's PLC device designation cannot be made.**
- **For GP70 Series, the data backup feature cannot be used, (only with Modbus PLUS).**
- **D-Script 's Memory Copy and Offset Address features cannot be used.**
- **The Logging and Filing Data features cannot be used.**
- **2-Way Driver can access to only LS Area.**
- **LS Area (Read Area) Restrictions**
Unable to write records in the Read Area that exceed the boundary of 1024 and 41 words.

Modbus Plus Adapter Module

The following drawing illustrates the Modbus Plus Adapter I/O module on a GP270 display.

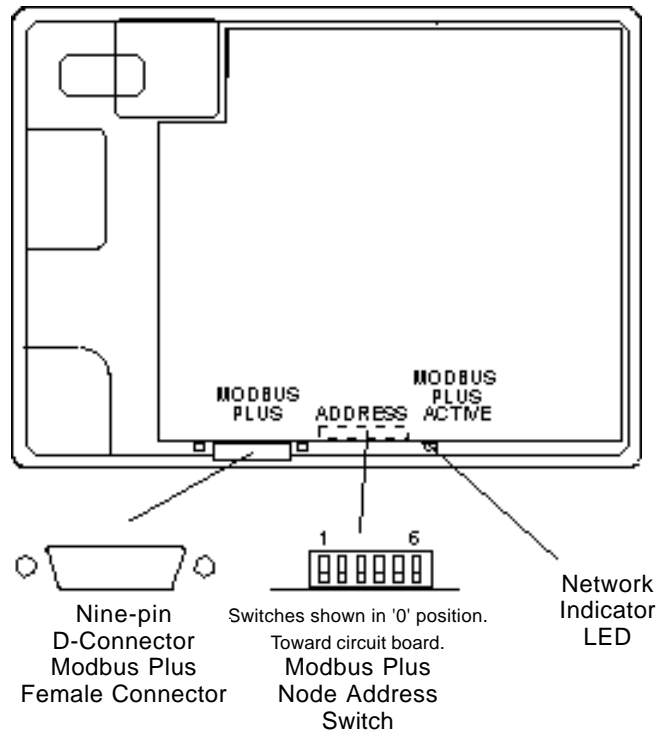

Station Address Switches

Station Address	Switch Positions					
	1	2	3	4	5	6
	(1)	(2)	(4)	(8)	(16)	(32)
1	0	0	0	0	0	0
2	1	0	0	0	0	0
26	1	0	0	1	1	0
32	1	1	1	1	1	0
64	1	1	1	1	1	1



Add one to switch a desired address setting. Switch down=ON=0.

Route Strings

Route strings are added to a variable name to locate the PLC address, which may be at the end of a chain. Each point on the link must be defined in order to arrive at the selected processor. For example, a route might be 60, 20, and 1, which would appear at the end of the variable name as 4100_60.20.1. If you define Route A as 60.20.1, then the variable name can be 4100_A. There are 26 route menus, designated A through Z.

The above setting can be made via the GP-PRO/PBIII System Settings area's "Option" menu.