

Device/PLC Connection Manuals



About the Device/PLC Connection Manuals

Prior to reading these manuals and setting up your device, be sure to read the "Important: Prior to reading the Device/PLC Connection manual" information. Also, be sure to download the "Preface for Trademark Rights, List of Units Supported, How to Read Manuals and Documentation Conventions" PDF file. Furthermore, be sure to keep all manual-related data in a safe, easy-to-find location.





5.8 Keyence

5.8.1 System Structure

The following describes the system structure for connecting the GP to Keyence PLCs.

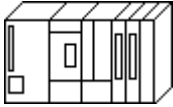



Reference The Cable Diagrams mentioned in the following tables are listed in the section titled "5.8.2 Cable Diagrams".

■ KZ-300/KZ-350 Series (using Link I/F)

CPU	Link I/F	Cable Diagram	GP
	PC Link Unit 		
KZ-300 KZ-350	KZ-L2 *1	(Cable Diagram 1)	GP Series

*1 Connect to Port 2.

■ KV-700 Series

CPU	Link I/F	Cable Diagram	GP
	PC Link Unit 		
KV-700	KV-L20	(Cable Diagram 1)	GP Series

5.8.2 Cable Diagrams

The cable lines illustrated below and the cable lines recommended by Keyence may differ; however, using these cables for your PLC operations will not cause any problems.

Cable Diagram 1

- When using Digital's RS-422 connector terminal adapter, GP070-CN10-O

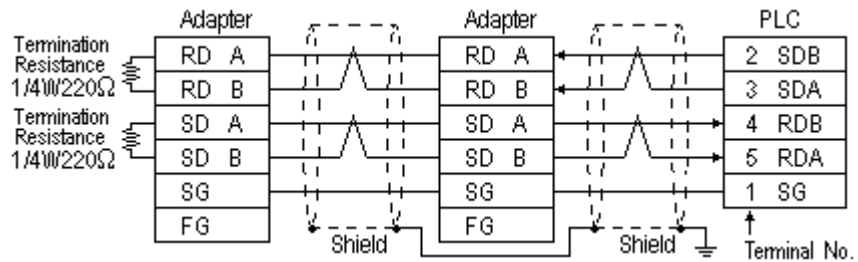

- When using Digital's Multi-link Cable, GP230-IS12-O

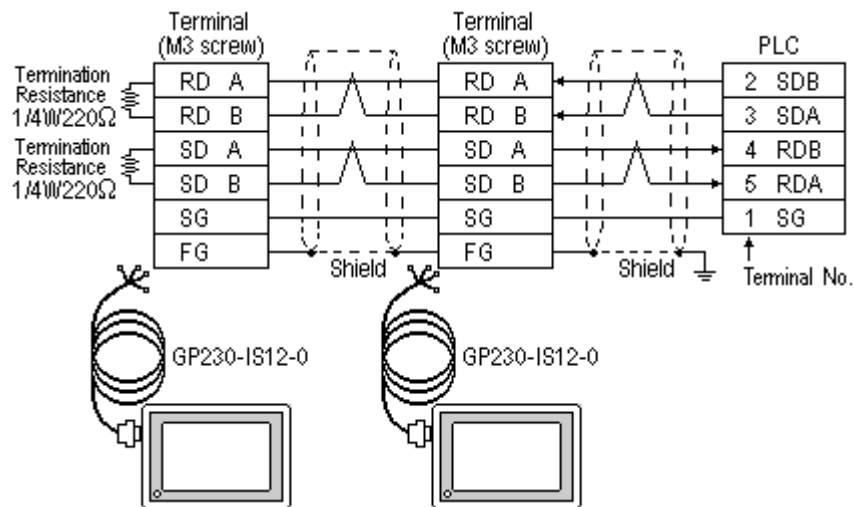

Cable Diagram 2

- When using Digital's RS-422 connector terminal adapter, GP070-CN10-O

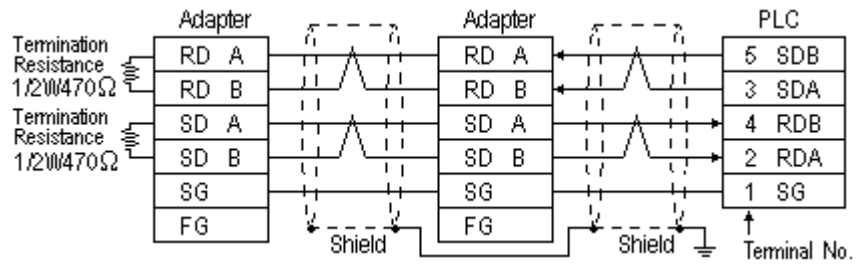

- When using Digital's Multi-link Cable, GP230-IS12-O

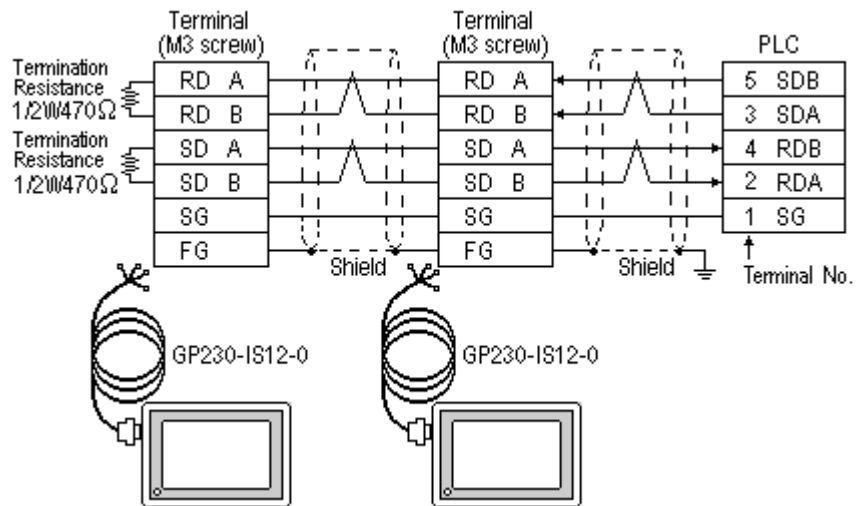



Ground your PLC's FG terminal according to your country's applicable standard. For details, refer to the corresponding PLC manual.



- The GP230-IS12-O Cable FG terminal is not connected to the GP's FG.
- Note that the naming/labeling of the A and B pins on the GP side is the reverse of the PLC side.
- Attach a Termination Resistor to both ends of the cable.
- For the RS-422 connection, refer to Keyence's PLC manual for the cable length.
- As a general rule, connect the PLC to one end of the circuit.

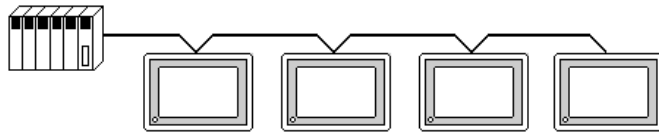

When making your own cable, Hirakawa's H-9293A (CO-HC-ESV-3P*7/0.2) cable is recommended.

The cable connection lines are as illustrated below. The cables between the GP and the terminals should be less than 10m.

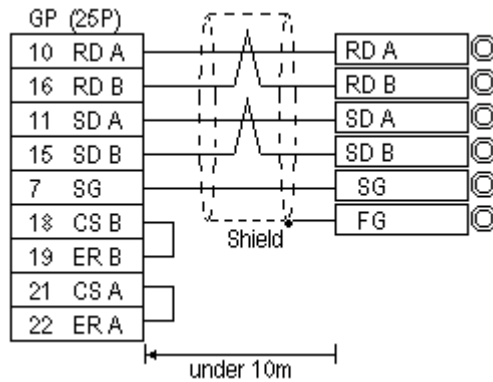



5.8.3 Supported Devices

The following describes the range of devices supported by the GP.



 Setup System Area or Communication Information's Storing Address here.

Device	Bit Address	Word Address	Particulars
Input Relay	00000 ~ 0009	00 ~ 00	L/H
	7000 ~ 17415	70 ~ 174	
Output Relay	0500 ~ 0503	05 ~ 05	
	7500 ~ 17915	75 ~ 179	
Auxiliary Relay	0504 ~ 0915	---	
Internal Relay	1000 ~ 6915	10 ~ 69	
Special Relay	2000 ~ 2915	20 ~ 29	
Timer (contact)	T000 ~ T249	---	
Counter (contact)	C000 ~ C249	---	
Timer (current value)		T000 ~ T249	
Counter (current value)		C000 ~ C249	
Data Memory		DM0000 ~ DM9999	
Temp. Data Memory		TM00 ~ TM31	

* 1 Address numbers *000~*400 are available for bit device addresses, and *0~*4 are available for word device addresses.

Bit Address	Word Address
addr 7000	70
addr 7100-7400	71-74
addr 8000	80
addr 8100-8400	81-84
addr 17000-17400	170-174

* 2 Address numbers *500~*900 are available for bit device addresses and *5~*9 are available for word device addresses.

Bit Address	Word Address
addr 7500	75
addr 7600-7900	76-79
addr 8500	85
addr 8600-8900	86-89
addr 17500-17900	175-179

■ **KV-700 Series** (using the KZ-300 series protocol)

Device	Bit Address	Word Address	Particulars
Input Relay	000000 ~ 00009	000 ~ 000	*1
Output Relay	00500 ~ 00503	005 ~ 005	
Internal AUX Relay	00504 ~ 00915	005 ~ 009	
Extended Input/Output Relay Internal AUX Relay	01000 ~ 59915	010 ~ 599	
Control Relay	60000 ~ 63915	600 ~ 639	*2
Timer (contact)	T000 ~ T511	---	*3
Counter (contact)	C000 ~ C511	---	*3
Timer (current value)	---	T000 ~ T511	*3
Counter (current value)	---	C000 ~ C511	*3
Data Memory	---	DM0000 ~ DM9999	*4
Temporary Data Memory	---	TM000 ~ TM511	[Bit] 5
Control Memory	---	TM0520 ~ TM4519	[Bit] 5 *5

*1 PLC or GP data writing is not possible.

*2 GP cannot write data to any address.

*3 Only available when the timer command and the counter command exist in the ladder program.

*4 The device range of the PLC is between DM0000 and DM19999, but only the addresses up to DM9999 are accessible to the GP.

*5 Certain addresses cannot be written to. For data write details, refer to your PLC's manual.

5.8.4 Environment Setup

The following lists Digital's recommended PLC and GP communication settings.

■ KZ-300/KZ-350 Series

GP Setup		PC Link Unit Setup	
Baud Rate	19200 bps	Baud Rate	19200 bps
Data Length	7 bits	Data Bit	7 bits
Stop Bit	2 bits	Stop Bit	2 bits
Parity Bit	Even	Parity Bit	Even
Data Flow Control	ER Control	---	
Communication Format	4-wire type	Port Toggle Switch	RS-422A
---		RUN Mode	Link Mode
Unit No.	0	Station Number	0

■ KV-700 Series (using the KZ-300 series protocol)

GP Setup		PLC Setup	
Baud Rate	19200 bps ^{*1}	Baud Rate	19200 bps
Data Length	7 bits	Data Length	7 bits
Stop Bit	2 bits	Stop	2 bits
Parity Bit	Even	Parity Bit	Even
Data Flow Control	ER Control	RS, CS Flow Control	No
Communication Format (RS-232C)	RS-232C	Communication Port 2 Selector Switch	232C
Communication Format (RS-422)	4-wire type	Communication Port 2 Selector Switch	422A
---		Operation Mode	Link Mode
Unit No.	0	Station No.	0

**1 The maximum baud rate is 115,200 bps.*

