

Device/PLC Connection Manuals



About the Device/PLC Connection Manuals

Prior to reading these manuals and setting up your device, be sure to read the "Important: Prior to reading the Device/PLC Connection manual" information. Also, be sure to download the "Preface for Trademark Rights, List of Units Supported, How to Read Manuals and Documentation Conventions" PDF file. Furthermore, be sure to keep all manual-related data in a safe, easy-to-find location.





2.18 Keyence

2.18.1 System Structure

The following describes the system structure for connecting the GP to Keyence PLCs.

Reference *The Cable Diagrams mentioned in the following tables are listed in the section titled "2.18.2 Cable Diagrams".*

■ KZ-300/KZ-350 Series (using Link I/F)





CPU	Link I/F	Cable Diagram	GP
	 PC Link Unit		
KZ-300 KZ-350	KZ-L2	RS-232C Port 1 Connection (Cable Diagram 1) RS-232C Port 2 Connection (Cable Diagram 2) RS-422 Port 2 Connection (Cable Diagram 3)	GP Series

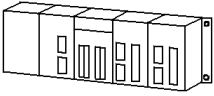

Note:

Port 1 and Port 2 can be connected at the same time on the GP. When connected at the same time, the Communication Setup for Port 1 and Port 2 must be the same.



■ KZ-A500 Series (using Link I/F)

CPU	Link I/F	Cable Diagram	GP
			
KZ-A500	KZ-L10	RS-232C, connected to Port 1. (Cable Diagram 4) RS-232C, connected to Port 2. (Cable Diagram 2) RS-232C, connected to Port 2. (Cable Diagram 3)	GP Series



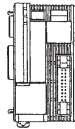
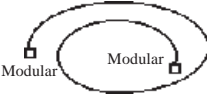
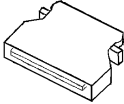

Port 1 (RS232C), Port 2 (RS232-C or RS422) and the modular controller on CPU unit can be used at the same time.

■ **KZ-A500 (CPU Direct Connection)**

CPU	Cables	Connector	GP
			
KZ-A500	Keyence Corp.'s OP-26487	Keyence Corp.'s OP-26485 ^{*1}	GP Series

**1 The above CPU cannot be directly connected to GP2300/GP2301/GLC2300 series units because of the connector cover size. In this case, use Digital's CA1-EXCBL/D25-01 extension cable.*

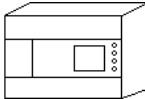
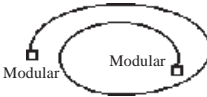
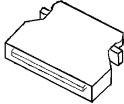



■ **Visual KV Series (CPU Direct Connection)**

CPU	Cables	Connector	GP/GLC
			
KV-10A□,KV-10D□ ^{*1} KV-16A□,KV-16D□ KV-24A□,KV-24D□ KV-40A□,KV-40D□	Keyence Corp.'s OP-26487	Keyence Corp.'s OP-26485 ^{*2}	GP Series GLC Series

**1 The value of □ depends on the PLC specifications.*

**2 The above CPU cannot be directly connected to GP2300/GP2301/GLC2300 series units because of the connector cover size. In this case, use Digital's CA1-EXCBL/D25-01 extension cable.*

■ **KV-700 Series (using Link I/F)**

CPU	Link I/F	Cable Diagram	GP/GLC
	PC Link Unit 		
KV-700	KV-L20	RS-232C (Communication Port 1) <Cable Diagram 5> RS-232C (Communication Port 2) <Cable Diagram 6> RS-422 (Communication Port 2) <Cable Diagram 7>	GP Series GLC Series

■ KV-700 Series (CPU Direct Connection)

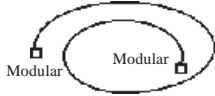
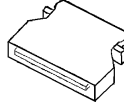
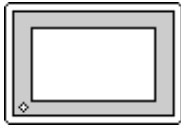
CPU	Cables	Connector	GP/GLC
			
KV-700	Keyence Corp.'s OP-26487	Keyence Corp.'s OP-26485 ^{*1}	GP Series ^{*2} GLC Series

*1 The above CPU cannot be directly connected to GP2300/GP2301/GLC2300 series units because of the connector cover size. In this case, use Digital's CA1-EXCBL/D25-01 extension cable.

*2 In the GP70 series units, only GP377 series units can be used.

■ KV Series (CPU Direct Connection)

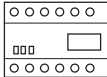
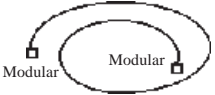
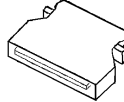
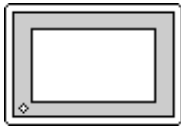
CPU	Cables	Connector	GP/GLC
			
KV-10RW, KV-10T2W KV-16RW, KV-16T2W KV-24RW, KV-24T2W KV-40RW, KV-40T2W KV-80RW, KV-80TW	Keyence Corp.'s OP-26487	Keyence Corp.'s OP-26485 ^{*1}	GP Series ^{*2} GLC Series

*1 The above CPU cannot be directly connected to GP2300/GP2301/GLC2300 series units because of the connector cover size. In this case, use Digital's CA1-EXCBL/D25-01 extension cable.

*2 GP70 Series (except for GP377 Series units) and GLC100 Series units cannot be used.

2.18.2 Cable Diagrams

The cable diagrams illustrated below and the cable diagrams recommended by Keyence may differ, however, using these cables for your PLC operations will not cause any problems.



- Connect the FG line of the Shield cable to the GP.
- For the RS-232C connection, use a cable length less than 15m.
- If a communications cable is used, it must be connected to the SG (signal ground).
- For the RS-422 connection, refer to Keyence's PLC manual for the cable length.

Cable Diagram 1 (RS-232C)

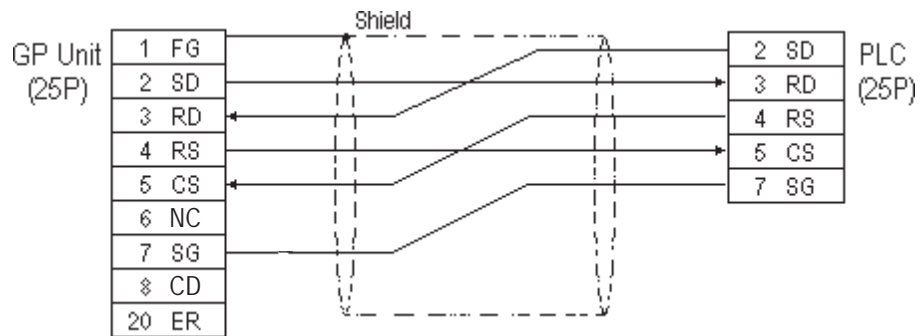

Cable Diagram 2 (RS-232C)

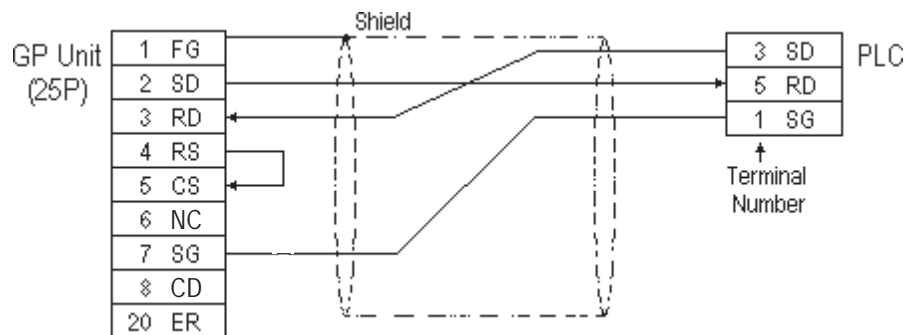

Cable Diagram 3 (RS-422)



Turn the PLC's Termination Resistor switch ON.



The reading of the A and B signals is reversed on the GP and PLC.

- When using Digital's RS-422 connector terminal adapter, GP070-CN10-0

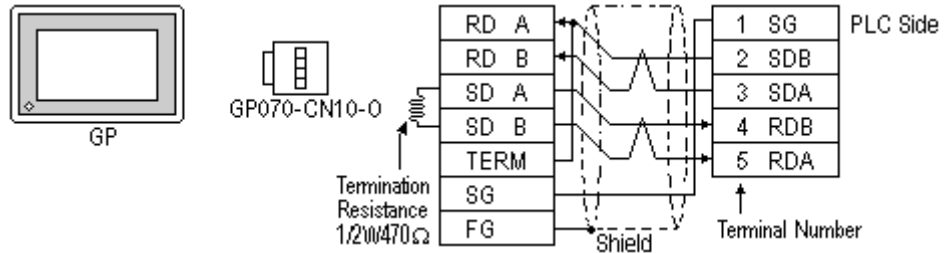

- When using Digital's RS-422 Cable, GP230-IS11-0

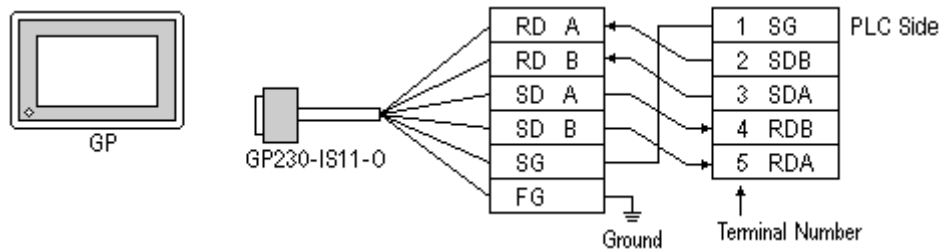

- When making your own cable connections

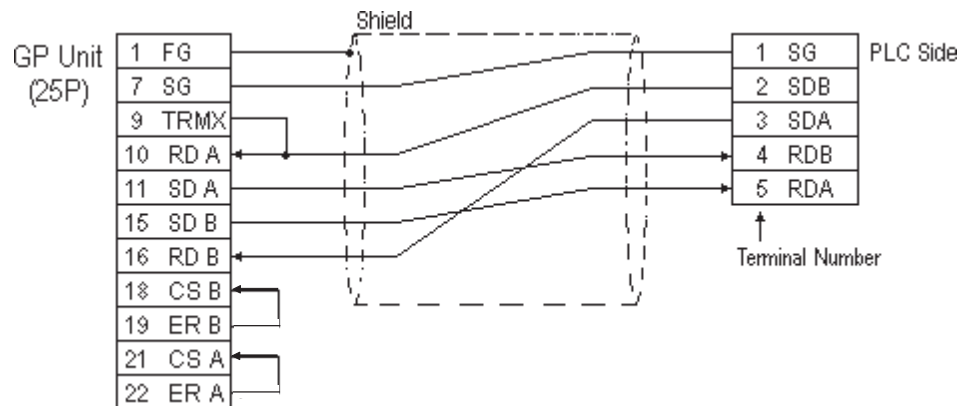

- Hidakawa Densen's H-9293A (C0-HC-ESV-3P*7/0.2) is the recommended cable.
- When connecting the #9 and #10 pins in the GP Serial I/F, a termination resistance of 100Ω is added between RDA and RDB.
- When using RS-422 connection, please check the cable length with Keyence PLC users manual.

Cable Diagram 4 (RS-232C) port1



- When using an RS-232C cable, the cable must be no longer than 15meters.
- When using an RS-422 cable, the cable must be no longer than 500meters.

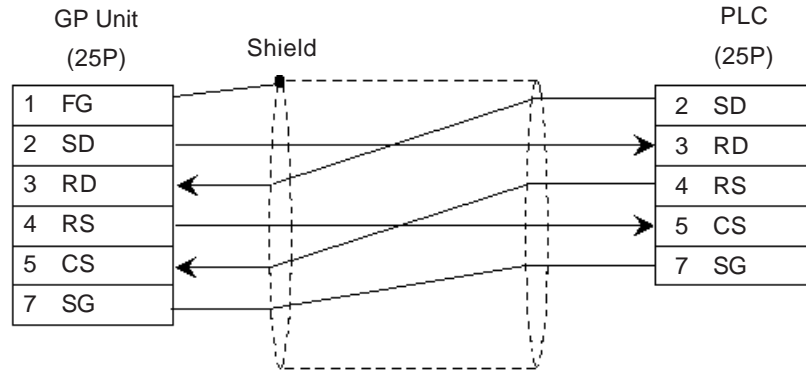

Cable Diagram 5 (RS-232C) port 1

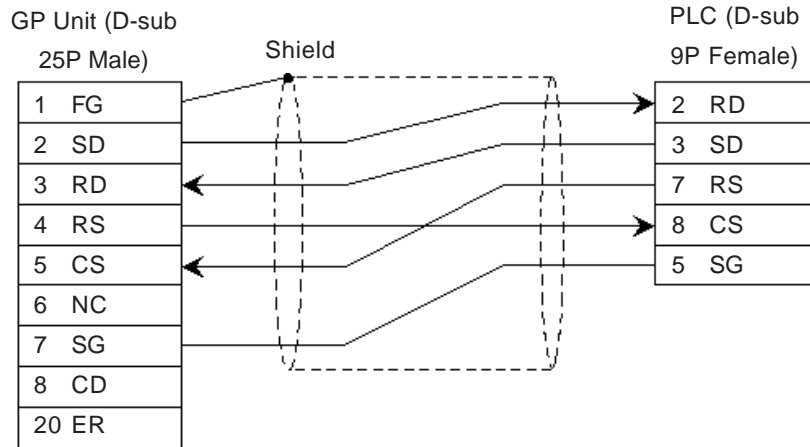

Cable Diagram 6 (RS-232C) port 2

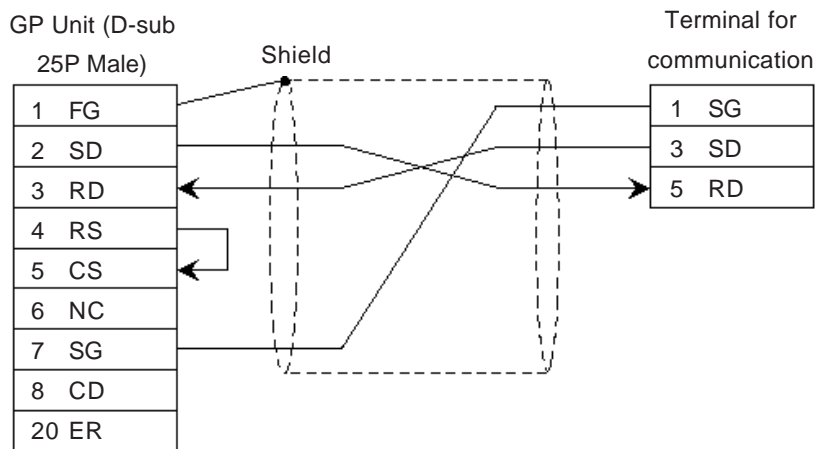

Cable Diagram 7 (RS-422) 4-wire type



- The termination resistance on the PLC side becomes active when the Terminator Select switch on the unit is turned ON.
- The names of poles A and B are inverted between the GP and the PLC.
- The cable length should be within 500 meters.
- When using Digital's RS-422 connector terminal adapter, GP070-CN10-0

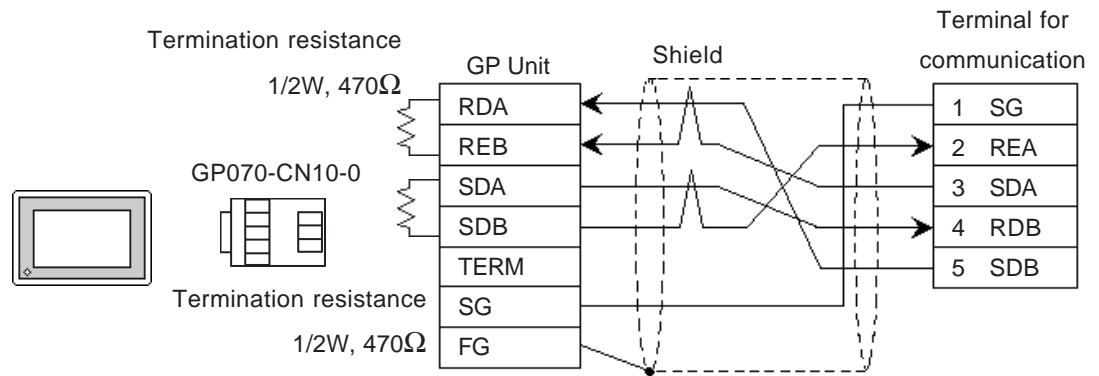

- When using Digital's RS-422 Cable, GP230-IS11-0

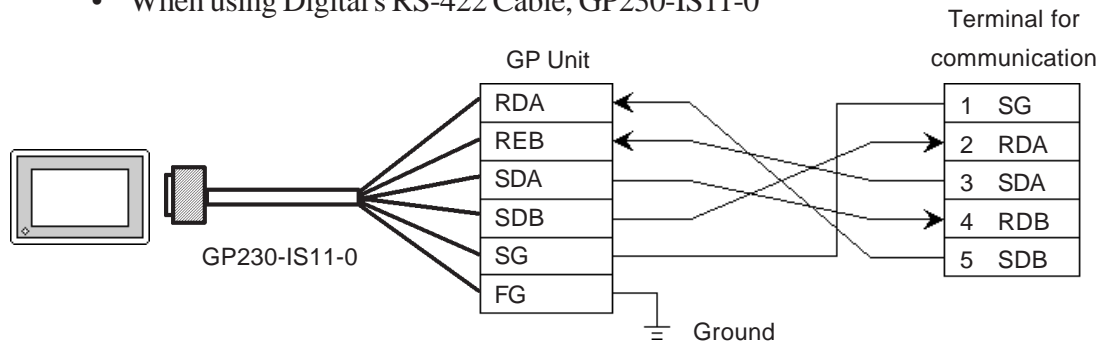

- When making your own cable connections

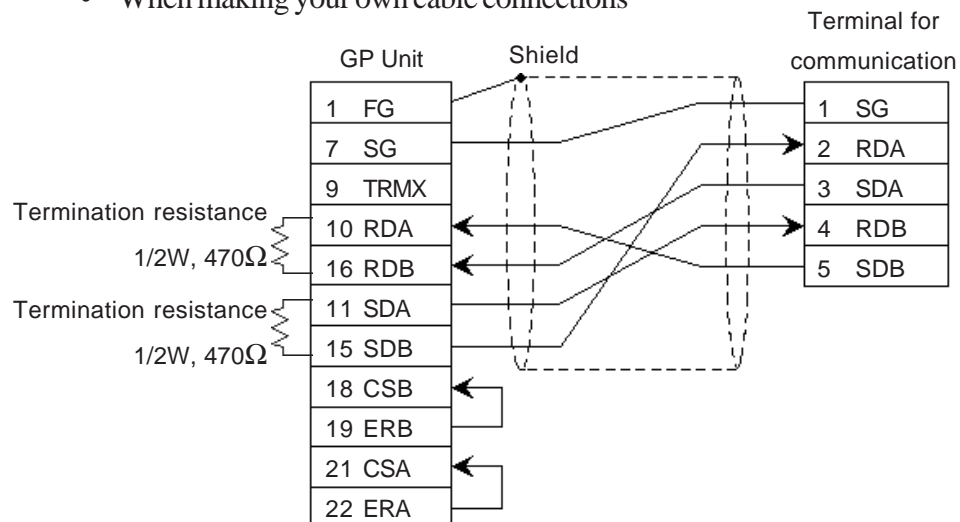

2.18.3 Supported Devices

The following describes the range of devices supported by the GP.

■ **KZ-300/KZ-350 Series** Set up System Area here.

Device	Bit Address	Word Address	Particulars
Input Relay	0000 ~ 0009	00 ~ 00	L/H
	7000 ~ 17415	70 ~ 174	
Output Relay	0500 ~ 0503	05 ~ 05	
	7500 ~ 17915	75 ~ 179	
Help Relay	0504 ~ 0915	---	
Internal Help Relay	1000 ~ 6915	10 ~ 69	
Special Help Relay	2000 ~ 2915	20 ~ 29	
Timer (contact)	T000 ~ T249	---	
Counter (contact)	C000 ~ C249	---	
Timer (current value)	---	T000 ~ T249	
Counter (current value)	---	C000 ~ C249	
Data Memory	---	DM0000 ~ DM9999	
Temporary Data Memory	---	TM00 ~ TM31	Bit 5

* 1 Address numbers *000~*400 are available for the bit device addresses, and *0~*4 are available for the word addresses displayed.

Bit Address	Word Address
addr 7000	70
addr 7001 to addr 7400	71 to 74
addr 8000	80
addr 8100 to addr 8400	81 to 84
addr 17000 to addr 17400	170 to 174

* 2 Address numbers *500~*900 are available for the bit device addresses, and *5~*9 are available for the word addresses displayed.

Bit Address	Word Address
addr 7500	75
addr 7600 to addr 7900	76 to 79
addr 8500	85
addr 8600 to addr 8900	86 to 89
addr 17500 to addr 17900	175 to 179

■ **KZ-A500** (CPU Direct Connection)

Set up System Area here.

Device	Bit Address	Word Address	Particulars
Input Relay	X0000 ~ X07FF	X0000 ~ X07F0	
Output Relay	Y0000 ~ Y07FF	Y0000 ~ Y07F0	
Internal Relay	M0000 ~ M8191	M000 ~ M8176	
Latch Relay	L0000 ~ L8191	---	
Special Relay	M9000 ~ M9255	M9000 ~ M9240	
Annunciator	F0000 ~ F2047	F0000 ~ F2032	
Link Relay	B0000 ~ B0FFF	---	
Timer (contact)	TS0000 ~ TS2047	---	
Timer (coil)	TC0000 ~ TC2047	---	
Counter (contact)	CS0000 ~ CS1023	---	
Counter (coil)	CC0000 ~ CC1023	---	
Timer (current value)	---	TN0000 ~ TN2047	
Counter (current value)	---	CN0000 ~ CN1023	
Data Register	---	D0000 ~ D6143	
Special Register	---	D9000 ~ D9255	
Link Register	---	W0000 ~ W0FFF	
File Register	---	R0000 ~ R8191	

L/H

■ KZ-A500 (using Link I/F)

Set up System Area here.

Device	Bit Address	Word Address	Particulars	
Input Relay	X0000 ~ X07FF	X0000 ~ X07F0	***0	L/H
Output Relay	Y0000 ~ Y07FF	Y0000 ~ Y07F0	***0	
Internal Relay	M0000 ~ M8191	M0000 ~ M8176	÷16	
Latch Relay	L0000 ~ L8191	L0000 ~ L8176	÷16	
Link Relay	B0000 ~ B0FFF	—————		
Annunciator Relay	F0000 ~ F2047	F0000 ~ F2032	÷16	
Special Relay	M9000 ~ M9255	M9000 ~ M9240	÷16	
Timer (connect)	TS0000 ~ TS2047	—————		
Timer (coil)	TC0000 ~ TC2047	—————		
Counter (connect)	CS0000 ~ CS1023	—————		
Counter (coil)	CC0000 ~ CC1023	—————		
Timer (current value)	—————	TN0000 ~ TN2047		
Counter (current value)	—————	CN0000 ~ CN1023		
Data Register	—————	D0000 ~ D6143	Bit15	
Link Register	—————	W0000 ~ W0FFF	BitF	
File Register	—————	R0000 ~ R8191	Bit15	
Special Register	—————	D9000 ~ D9255	Bit15	

■ Visual KV Series (KV-10A/KV-10D/KV-16A/KV-16D//KV-24A/KV-24D/KV-40A/KV-40D)

 Set up System Area here.

Device	Bit Address	Word Address	Particulars	
Input/Output Relay	00000 ~ 00915	000 ~ 009	L/H	
	07000 ~ 17915	070 ~ 179		
Internal AUX Relay	01000 ~ 01915	010 ~ 019		
	03000 ~ 06915	030 ~ 069		
Special AUX Relay	02000 ~ 02915	020 ~ 029		*1
Timer (contact)	T000 ~ T249	_____		
Counter (contact)	C000 ~ C249	_____		
High-Speed Counter Comparator (contact)	CTC0 ~ CTC3	_____		*2
Timer (set value)	_____	TS000 ~ TS249		
Counter (set value)	_____	CS000 ~ CS249		
Timer (current value)	_____	TC000 ~ TC249		
Counter (current value)	_____	CC000 ~ CC249		
Data Memory	_____	DM0000 ~ DM1999		Bit [5]
Temporary Data Memory	_____	TM00 ~ TM31		Bit [5]
Digital Trimmer	_____	AT0 ~ AT1		*2
High-Speed Counter (current value)	_____	CTH0 ~ CTH1		
High-Speed Counter Comparator (set value)	_____	CTC0 ~ CTC3		

*1 Some addresses are not available for writes.

*2 Not available for writes

■ KV-700 Series (using the KZ-300 series protocol)







 Set up System Area here.

Device	Bit Address	Word Address	Particulars
Input Relay	00000 ~ 00009	000 ~ 000	*1
Output Relay	00500 ~ 00503	005 ~ 005	
Internal AUX Relay	00504 ~ 00915	005 ~ 009	
Extended Input/Output Relay Internal AUX Relay	01000 ~ 59915	010 ~ 599	
Control Relay	60000 ~ 63915	600 ~ 639	*2
Timer (contact)	T000 ~ T511	_____	*3
Counter (contact)	C000 ~ C511	_____	*3
Timer (current value)	_____	T000 ~ T511	*3
Counter (current value)	_____	C000 ~ C511	*3
Data Memory	_____	DM0000 ~ DM9999	Bit 5 *4
Temporary Data Memory	_____	TM000 ~ TM511	Bit 5
Control Memory	_____	TM0520 ~ TM4519	Bit 5 *5

- *1 PLC or GP data writing is not possible.
- *2 GP cannot write data to any address.
- *3 Only available when the timer command and the counter command exist in the ladder program.
- *4 The device range for the PLC is between DM0000 and DM19999, but addresses up to DM9999 are only accessible to the GP.
- *5 Some addresses are not available for writes.

■ KV-700 Series (using the KZ-A500 (link) protocol)

 Set up System Area here.

Device	Bit Address	Word Address	Particulars	
Input Relay	X000 - X009	X00 - X00	 *1*2	L/H
Output Relay	X050 - X053	X05 - X05	 *2	
Internal AUX Relay	X054 - X09F	X05 - X09	 *2	
Control Relay	M0000 - M3915	M0000 - M3904	 *3*4	
Timer (contact)	TS000 - TS511	—————	*5	
Counter (contact)	CS000 - CS511	—————	*5	
High-Speed Counter Comparator (contact)	CS512 - CS515	—————	*5*6	
Timer (current value)	—————	TN000 - TN511	*5	
Counter (current value)	—————	CN000 - CN511	*5	
High-Speed Counter (current value)	—————	CN512 - CN513	*5	
Data Memory	—————	D00000 - D19999	 *7*8	
Control Memory	—————	D50000 - D53999	 *7*3	

*1 PLC or GP data writing are not available for writes.

*2 Addresses must be specified using hexadecimal numbers.

*3 Some addresses are not available for writes.

*4 For addresses, only multiples of 16 may be specified.

*5 Only available when the timer command, the counter command, and the high-speed timer command exist in the ladder program.

*6 GP cannot write data to any address.

*7 Even if the file registers are registered as R50000 to R539999, similar device addresses can be used, e.g., R51111 = D51111.

■ KV-700 Series (CPU Direct Connection)

 Set up System Area here.

Device	Bit Address	Word Address	Particulars
Input/Output Relay	00000-59915	000-599	
Internal AUX Relay			
Control Relay	CR0000-CR3915	CR00-CR39	
Timer (contact)	T000-T511	_____	
Counter (contact)	C000-C511	_____	
High-Speed Counter Comparator (contact)	CTC0-CTC3	_____	*1
Timer (set value)	_____	TS000-TS511	*2
Counter (set value)	_____	CS000-CS511	*2
Timer (current value)	_____	TC000-TC511	*2
Counter (current value)	_____	CC000-CC511	*2
Data Memory	_____	DM00000-DM39999	Bit 5
Temporary Data Memory	_____	TM000-TM511	Bit 5
Control Memory	_____	CM0000-CM3999	Bit 5
Digital Trimmer	_____	TRM0-TRM7	*2
High-Speed Counter (current value)	_____	CTH0-CTH1	*2
High-Speed Counter Comparator (set value)	_____	CTC0-CTC3	*2

L/H

*1 Not available for writes.

*2 32-bit device

■ **KV Series** (KV-10RW/KV-10T2W/KV-16RW/KV-16T2W/KV-24RW/KV-24T2W/KV-40RW/KV-40T2W/KV-80RW/KV-80TW)

Set up System Area here.

Device	Bit Address	Word Address	Particulars	
Input/Output Relay	00000 - 00915		L/H	
Internal AUX Relay	01000 - 01915	_____		*1
	03000 - 06915			
Special AUX Relay	02000 - 02915	_____		*1
Timer (contact)	T000 - T119	_____		
Counter (contact)	C000 - C119	_____		
High-Speed Counter Comparator (contact)	CTC0 - CTC3	_____		*2
Timer (set value)	_____	TS000 - TS119		
Counter (set value)	_____	CS000 - CS119		
Timer (current value)	_____	TC000 - TC119		
Counter (current value)	_____	CC000 - CC119		
Data Memory	_____	DM0000 - DM1999		[Bit] 5]
Temporary Data Memory	_____	TM00 - TM31		[Bit] 5]
Analog Timer	_____	AT0 - AT1		*2
High-Speed Counter (current value)	_____	CTH0 - CTH1		
High-Speed Counter Comparator (set value)	_____	CTC0 - CTC3		

*1 Some addresses are not available for writes.

*2 Not available for writes



The device ranges available will depend on the PLC model used. Be sure to check your PLC's manual prior to connecting it to the GP.

2.18.4 Environment Setup

The following lists Digital's recommended PLC and GP communication setups.

■ KZ-300/KZ-350 Series

GP Setup		PC Link Unit Setup	
Baud Rate	19200 bps	Baud Rate	19200 bps
Data Length	7 bits	Data Bit	7 bits
Stop Bit	2 bits	Stop Bit	2 bits
Parity Bit	Even	Parity Bit	Even
Data Flow Control	ER Control	---	
Communication Format (RS-232C)	RS-232C	Port 2 Toggle Switch (RS-232C) ^{*1}	RS-232C
Communication Format (RS-422)	4-wire type	Port 2 Toggle Switch (RS-422) ^{*1}	RS-422A
---		RUN Mode	Link Mode
Unit No.	0	Station Number	0

**1 Setup not necessary when using Port1.*

■ KZ-A500 (CPU Direct Connection)

GP Setup		PLC Setup
Baud Rate	9600 bps	---
Data Length	8 bits (fixed)	---
Stop Bit	1 bit (fixed)	---
Parity Bit	Odd (fixed)	---
Data Flow Control	ER Control	---
Communication Format (RS-232C)	RS-232C	---
Unit No.	0 (fixed)	---



Effect of PLC program on cycle time

If the KZ-A500 is connected directly to the CPU, the cycle time of the PLC program is delayed by about 8% after communication with the GP begins.

■ **KZ-A500** (using Link I/F)

GP Setup		PLC Setup	
Baud Rate	19200bps ^{*1}	Baud Rate	19200bps
Data Length	7 bits	Data Length	7 bits
Stop Bit	1 bit	Stop Bit	1 bit
Parity Bit	None	Parity Bit	None
Data Flow Control	ER	_____	_____
Communication Format (RS-232C)	RS-232C	RS-232C Communication Port	Port 1 or Port 2 ^{*2}
Communication Format (RS-422)	4-Wire Type	RS-422 Communication Port	Port 2 ^{*3}
_____	_____	Communication Type	Normal
_____	_____	Changing device data during RUN	Possible
_____	_____	Checksum	Yes
_____	_____	Operation Mode	Protocol Mode 4
Unit No.	0	STATION No.	0

*1 The maximum baud rate is 38400bps.

*2 When using an RS-232C cable on port 2, be sure to set the INTERFACE switch to “232C”(right side setting.) Also, set the TERMINATOR switch to OFF, since it will not be used.

*3 When using an RS-422 cable, set the INTERFACE switch to “422”(left side setting,) and the TERMINATOR switch to ON.

■ **Visual KV/KV-700 Series** (CPU Direct Connection)

GP Setup		PLC Setup	
Baud Rate	19200bps	_____	_____
Data Length	8 bits (fixed)	_____	_____
Stop Bit	1 bit (fixed)	_____	_____
Parity Bit	Even (fixed)	_____	_____
Data Flow Control	ER Control	_____	_____
Communication Format	RS-232C	_____	_____
Unit No.	0	_____	_____



- The baud rate can be from 9600 to 57600 bps.
- The PLC requires no setup due to its automatic recognition of settings.

■ KZ-700 Series (using the KZ-300 series protocol)

GP Setup		PLC Setup	
Baud Rate	19200bps ^{*1}	Baud Rate	19200bps
Data Length	7 bits	Data Length	7 bits
Stop Bit	2 bits	Stop Bit	2 bits
Parity Bit	Even	Parity Bit	Even
Data Flow Control	ER Control	RS, CS Flow Control	No
Communication Format (RS-232C)	RS-232C	Communication Port 1	Fixed to 232C
		Communication Port 2 Selector Switch	232C
Communication Format (RS-422)	4-Wire Type	Communication Port 2 Selector Switch	422A
—————		Operation Mode	Link Mode
Unit No.	0	Station No.	0

**1 The maximum baud rate is 115,200 bps.*

■ KZ-700 Series (using the KZ-A500 series protocol)

GP Setup		PLC Setup	
Baud Rate	19200bps ^{*1}	Baud Rate	19200bps
Data Length	7 bits	Data Length	7 bits
Stop Bit	1 bits	Stop Bit	1 bits
Parity Bit	None	Parity Bit	None
Data Flow Control	ER Control	—————	
Communication Format (RS-232C)	RS-232C	Communication Port 1	Fixed to 232C
		Communication Port 2 Selector Switch	232C
Communication Format (RS-422)	4-Wire Type	Communication Port 2 Selector Switch	422A
—————		Operation Mode	Protocol Mode 4
—————		Checksum	Yes
Unit No.	0	Station No.	0

**1 The maximum baud rate is 115,200 bps.*

■ KV Series (CPU Direct Connection)

GP Setup		PLC Setup	
Baud Rate	19200bps	_____	_____
Data Length	8 bits (fixed)	_____	_____
Stop Bit	1 bit (fixed)	_____	_____
Parity Bit	Even (fixed)	_____	_____
Data Flow Control	ER Control	_____	_____
Communication Format	RS-232C	_____	_____
Unit No.	0 (fixed)	_____	_____



- The baud rate can be from 9600 to 38400 bps.
- The PLC requires no setup due to its automatic recognition of settings.
- If your ladder program is currently stopped and you attempt data transfer at 38400 bps, a communication error can occur. If it does, either change to RUN mode, or use a different communication speed.

2.18.5 Error Codes

■ PLC Error Codes

Controller error codes are indicated by the "Host communication error (02:**)", and appear in the left lower corner of the GP screen. (** stands for an error code.)

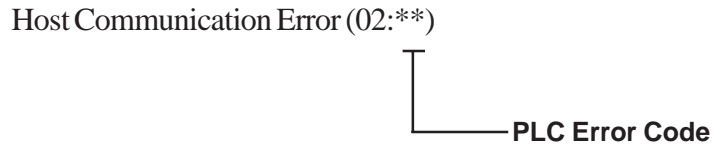

◆ Visual KV/KV-700 Series (CPU Direct Connection)

<PLC Error Code>

Error Code	Description
02	Occurs when you write to a device that cannot be written to. (High Speed Counter Comparator (contact))
04	Occurs when the PLC uses an unsupported baud rate to send data.
31	Occurs when an undefined device is accessed. *1

**1 When writing to a Timer (contact/current value/set value), Counter (contact/current value/set value), High Speed Counter, High Speed Counter Comparator (set value), these values must be set in advance using a Ladder Program.*

◆ KV Series (CPU Direct Connection)

<PLC Error Code>

Error Code	Description
02	A ladder program has not yet been set up in the PLC.
04	A Device was accessed that has not yet been defined.
13	Setting values were attempted to be changed for a write-protected program's Counters, Timers, and High-speed Counter Comparator.