

Device/PLC Connection Manuals



About the Device/PLC Connection Manuals

Prior to reading these manuals and setting up your device, be sure to read the "Important: Prior to reading the Device/PLC Connection manual" information. Also, be sure to download the "Preface for Trademark Rights, List of Units Supported, How to Read Manuals and Documentation Conventions" PDF file. Furthermore, be sure to keep all manual-related data in a safe, easy-to-find location.

2.14 Fanuc Motion Controllers

2.14.1 System Structure



The following describes the system structure for connecting the GP to Fanuc Motion Controller PLCs.

Reference The Cable Diagrams mentioned in the following tables are listed in the section titled "2.14.2 Cable Diagrams".



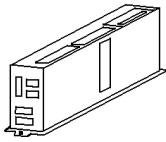

Be sure to inform the Fanuc Corporation clearly that the system will be connected with GP series unit(s).

■ FANUC Power Mate Series

CPU	Cable Diagram	GP
		
Power Mate -MODEL D	RS-422 (Cable Diagram 1)	GP Series

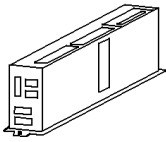
■ FANUC Series

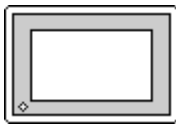
CPU	Cable Diagram	Cables	GP
			
16-MC ^{*1}	RS-232C (Cable Diagram 2)	Digital's GP410-IS00-O(5m)	

*1 When connecting to 16-MC, Fanuc's converting cable A02B-0120-C19 is needed to connect a D-Sub connector (20pins) and a D-Sub connector (25pins).

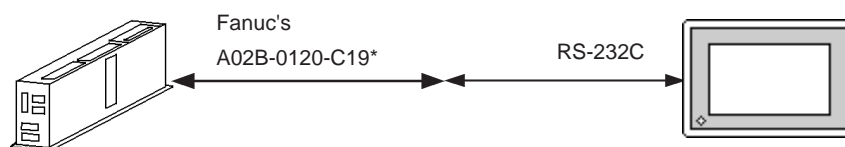

The 16-MC unit can be connected only to serial port 2 (JD5B). It cannot be connected to serial port 1 (JD5A).

2.14.2 Cable Diagrams

The cable diagrams illustrated below and the cable diagrams recommended by GE Fanuc Automation may differ, however, using these cables for your PLC operations will not cause any problems.



- Connect a Termination Unit to the Motion Controller's JD15. The Termination Unit, with a resistance of 100Ω is connected to the RD B and RD A points.

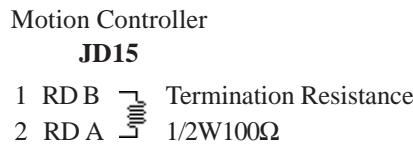

- Ground your Motion Controller Unit's FG terminal. For details, refer to the Motion Controller manual.
- Ground the Shield to the Cable Clamp.
- If a communications cable is used, it must be connected to the SG (signal ground).



When using RS-422 connection, check the cable length with Fanuc Motion Controller PLC's users manual.

Cable Diagram 1 (RS-422)

- When using Digital's RS-422 connector terminal adapter GP070-CN10-0

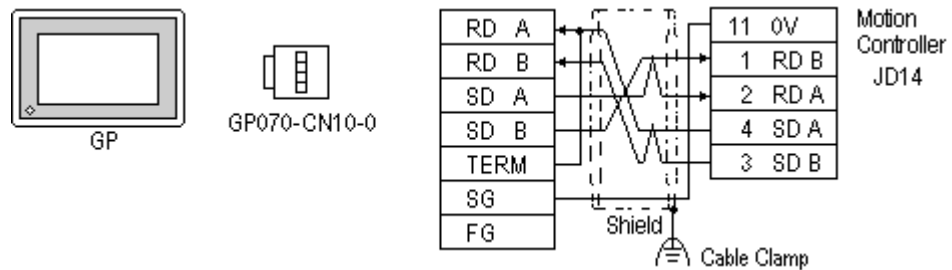

- When making your own cable connections

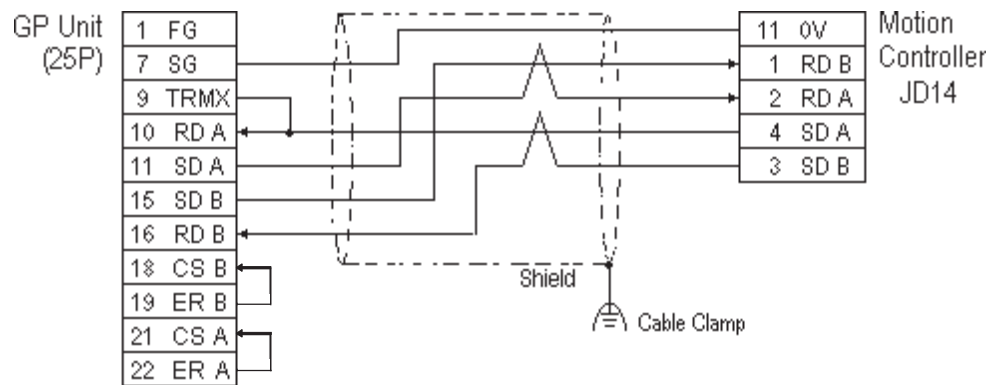

- **Recommended Cable:** Oki Densen's A66L-0001-0284#10P
- **Recommended Connector:** Honda Tsushin Kogyo's PCR-E20FS
- **Recommended Connector Case:** Honda Tsushin Kogyo's PCR-V20LA
- **When connecting the #9 and #10 pins in the GP Serial I/F, a termination resistance of 100Ω is added between RDA and RDB.**

Cable Diagram 2 (RS-232C)

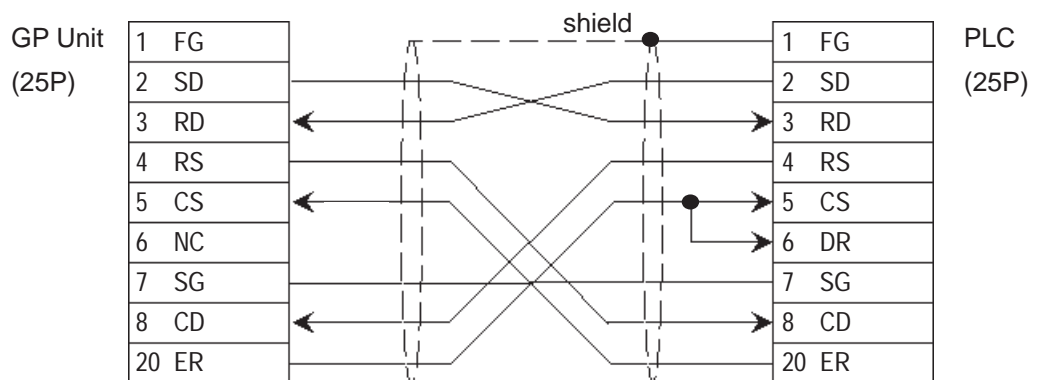

2.14.3 Supported Devices

The following describes the range of devices supported by the GP.

■ FANUC Power Mate Series Setup System Area here.

Device	Bit Address	Word Address	Particulars
Input Relay (X)	X000000 - X001277 X010000 - X010637	X00000 - X00126 X01000 - X01062	÷2
Output Relay (Y)	Y000000 - Y001277 Y010000 - Y010637	Y00000 - Y00126 Y01000 - Y01062	÷2
Internal Relay (R)	R000000 - R009997	R00000 - R00998	÷2
Keep Relay (K)	K00000 - K00197	K0000 - K0018	÷2
Timer (T)	---	T0000 - T0078	÷2
Counter (C)	---	C0000 - C0078	÷2
Data Table (D)	---	D0000 - D01858	÷2 Bit 7

L/H

- The address' High/Low relationship is as follows:

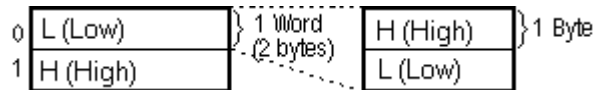

- When entering the *Input Relay, Output Relay, Internal Relay, and Data Table*, enter a 0, after each letter (X,Y,R,D). (The values in the table above already have a 0 added.)

E.g. X0 0120; Y0 01000

- A PLC Communication Error develops when an address outside the range is entered.

E.g. HOST COMMUNICATION ERROR (02 : 0F : * *)

**	Meaning	Solution
04	The entered address does not exist.	Check the range of available Motion Controller addresses, and setup all addresses within this range.
05	The entered data length is incorrect.	

Input Bit Address data using Decimal/Octal.



E.g. K0063 7
 Decimal └┬┘ └┬┘ Octal

2.14.4 Environment Setup

The following lists Digital's recommended Motion Controller and GP communication settings.

■ FANUC Power Mate Series

GP Setup		Motion Controller JD14 Setup
Baud Rate	19200 bps (fixed)	---
Data Length	8 bits (fixed)	---
Stop Bit	1 bit (fixed)	---
Parity Bit	Even (fixed)	---
Data Flow Control	ER Control (fixed)	---
Communication Format	4-wire type (fixed)	---
Unit No.	0 (fixed)	---

■ FANUC Series

GP Setup		JD5P Setup
Baud Rate	19200bps(fixed)	-----
Data Length	8bits(fixed)	-----
Stop Bit	1bit(fixed)	-----
Parity Bit	Even(fixed)	-----
Data Flow Control	ER Control (fixed)	-----
Communication Format	RS232C	-----
Unit No.	0 (fixed)	-----

