

# Device/PLC Connection Manuals

---



## About the Device/PLC Connection Manuals

Prior to reading these manuals and setting up your device, be sure to read the "Important: Prior to reading the Device/PLC Connection manual" information. Also, be sure to download the "Preface for Trademark Rights, List of Units Supported, How to Read Manuals and Documentation Conventions" PDF file. Furthermore, be sure to keep all manual-related data in a safe, easy-to-find location.

# 1

## Connecting an ST Unit

### 1.1

#### Connecting an ST Unit

##### ■ ST Optional Items

The following optional cables can be used to connect a PLC to your ST unit.

Item	Description
RS232C Cable CA3-CBL232/5M-01 (5m)	I/F cable used for data transfer between each Device/PLC and your ST unit
RS422 Cable CA3-CBL422/5M-01 (5m)	
Mitsubishi PLC FX-Series Connection Cable CA3-CBLFX/1M-01 (1m)	I/F cable used for data transfer between Mitsubishi FX-Series PLCs and your ST unit
Mitsubishi PLC FX-Series Connection Cable CA3-CBLFX/5M-01 (5m)	

##### ■ Connection Method

This manual includes connection diagram(s) of the wiring connections to be used between the GP and a PLC. However, the pin number assigned to each connector pin on the ST's interface will differ from that of other GP series units. Therefore, be sure to use the following Connector Pin Comparison Tables 1, 2 and 3 when creating a cable. Setup procedures are similar to those for GP Series units.

**Table 1: RS232C I/F**

ST Unit Pin No.	ST Signal Name	GP Series Unit Pin No.
1	CD	8
2	RD	3
3	SD	2
4	ER	20
5	SG	7
6	DR	6
7	RS	4
8	CS	5
9	RI	17 <sup>*1</sup>
Connector Shell	FG	1

*\*1 Only GP2000 Series units.*

**Table 2: RS422 I/F**

ST Unit Pin No.	ST Signal Name	GP Series Unit Pin No.
1	RDA	10
2	RDB	16
3	SDA	11
4	ERA	22
5	SG	7
6	CSB	18
7	SDB	15
8	CSA	21
9	ERB	19
Connector Shell	FG	1



- Be sure to connect this unit's pin #5 (SG) to the other unit's SG terminal.
- When creating an option cable, please be aware of the following:  
**<RS422 type Connection>**  
**The following pairs of pin numbers must be connected to each other:**  
**#8 (CSA) <-> #4 (ERA)**  
**#6 (CSB) <-> #9 (ERB)**

**Table 3: RS485 I/F (MPI Direct Connection)**

ST Unit Pin No.	ST Signal Name	GP Series Unit Pin No.
1	NC	
2	NC	
3	LINE (+)	10, 11
4	Reserve	
5	GND	7
6	+5V	
7	NC	
8	LINE (-)	15, 16
9	NC	



**For SIEMENS S7-200/300/400 Series units, be sure to use a SIEMENS Co. Profibus Connection when connecting directly to an MPI Port.**

◆ **Example - Converting to ST Pin Nos.**

The following example connects an ST unit to a Mitsubishi PLC (2-1-8 Cable Diagram 1) and describes how to convert the pin assignments for other GP Series units to those on the ST unit.

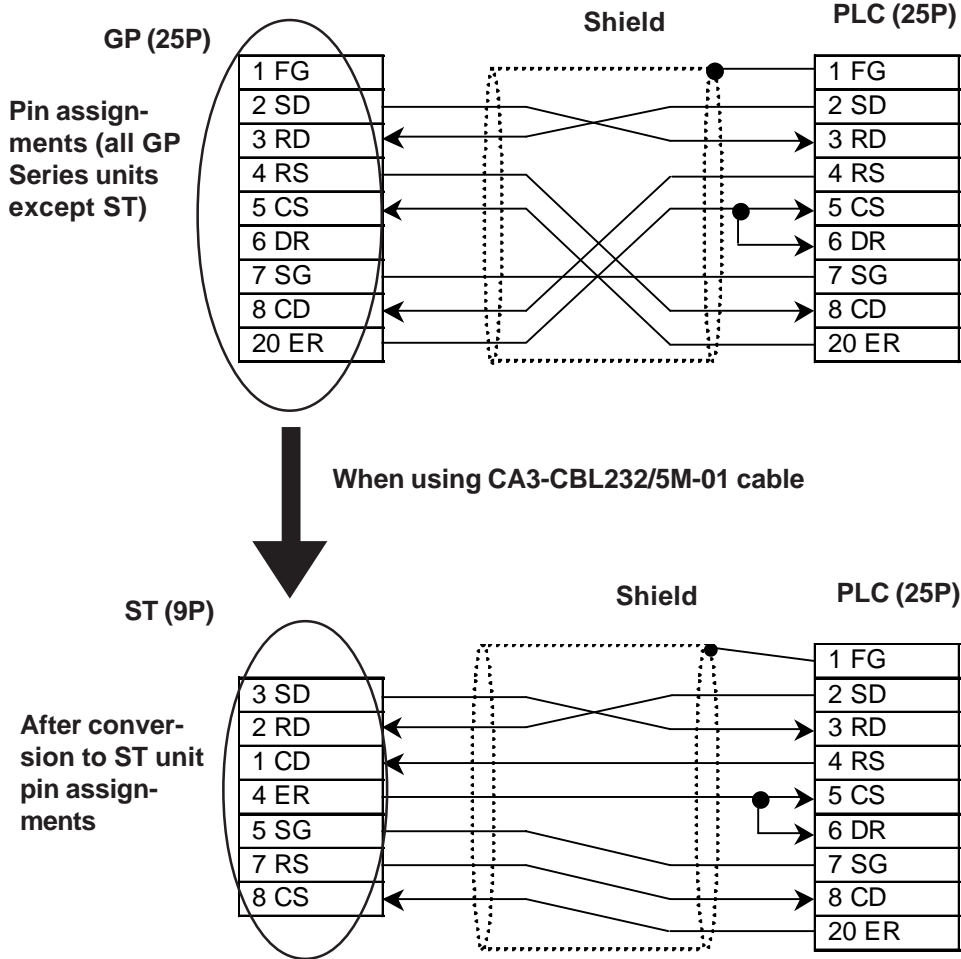

- **Check that unused wires do not touch other signal wires or the connector case.**
- **Be sure to connect the cable's outer shield to the FG wire.**

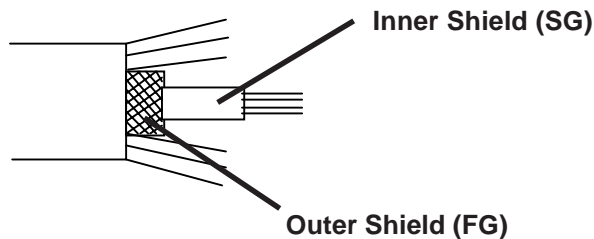

- **Be sure to connect the inner shield to the Device/PLC's SG, in the same way as Pin #5's SG.**

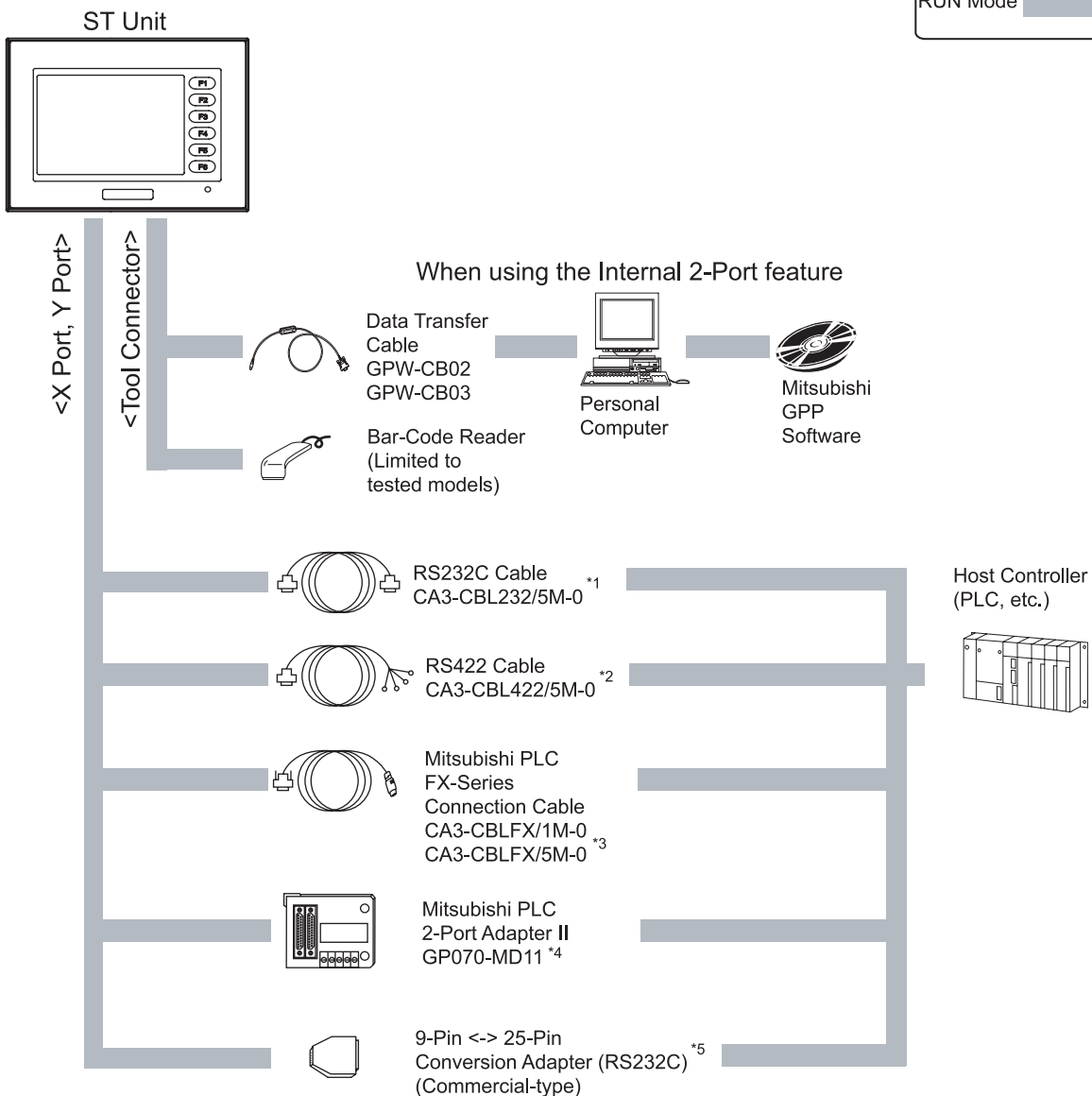

\*1 Equivalent to the optional cable GP410-IS00-O. PLCs that can be connected to the GP410-IS00-O optional cable can also be connected to this cable.

\*2 Equivalent to the optional cable GP230-IS11-O. Pins #1 (RDA) and #2 (RDB) have termination resistance (1/2W 100Ω). Therefore, when using this cable for multi-link communication, be sure to remove this termination resistance.

\*3 Mitsubishi FX-Series PLC Direct Connection Cable. This cable is equivalent to Pro-face's GP2000-CBLFX/1M-01 and GP2000-CBLFX/5M-01 cables, and is used for a D-sub25 pin connection.

\*4 For connection method details,

▼ **Reference** ▲ 1.3 Cable Diagrams, ■ 2-Port Adapter II (GP070-MD11)

\*5 For connection method details,

▼ **Reference** ▲ 1.3 Cable Diagrams, ■ 9-Pin <-> 25-Pin Conversion Adapter

### 1.3

### Cable Diagrams

#### ■ RS232C (CA3-CBL232/5M-01)

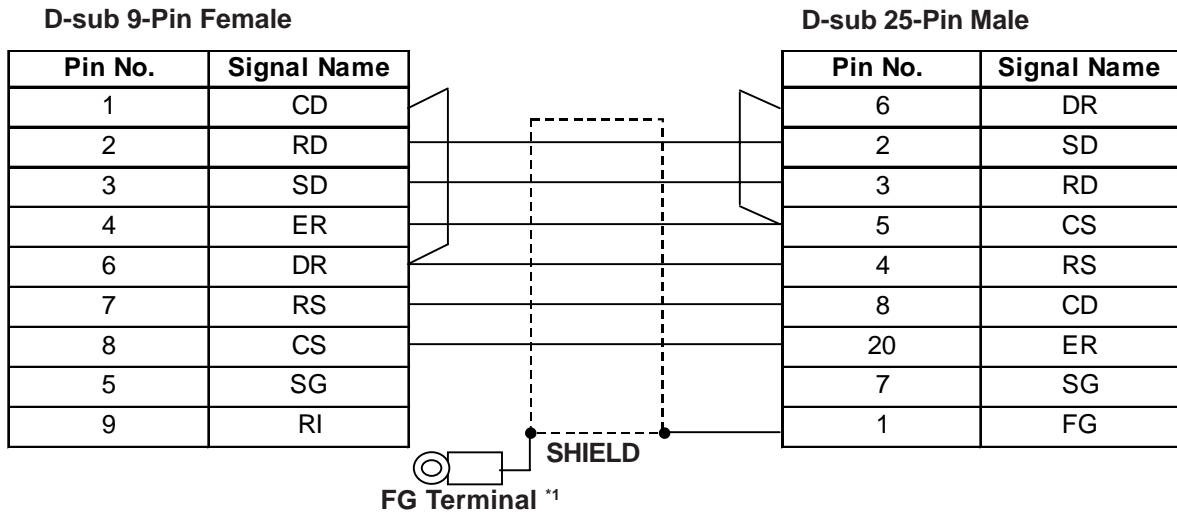

\*1 Be sure to connect the ST unit's FG terminal to the other unit's FG terminal. To do this, remove the D-sub 9-Pin's fastener screws, insert the FG terminal, and replace the fastener screws.

#### ■ RS422 (CA3-CBL422/5M-01)

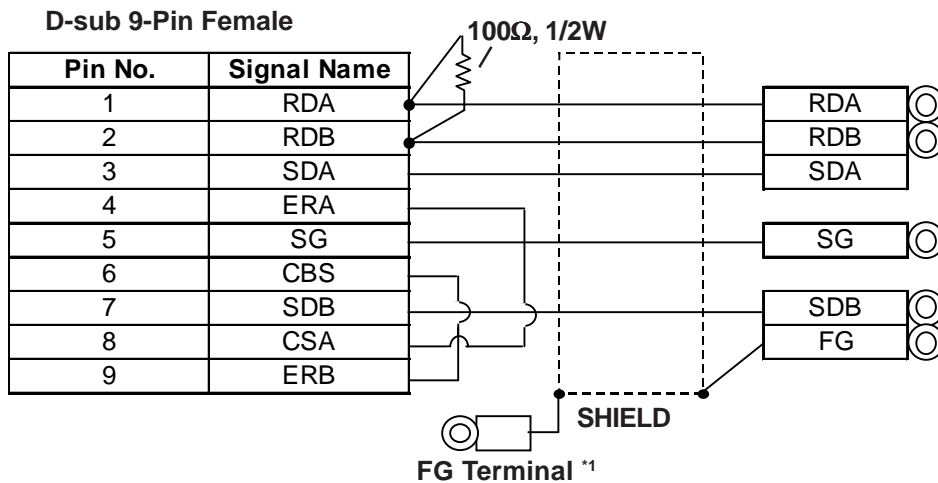

\*1 Be sure to connect the ST unit's FG terminal to the other unit's FG terminal. To do this, remove the D-sub 9-Pin's fastener screws, insert the FG terminal, and replace the fastener screws.

#### ■ FX Connection (CA3-CBLFX/1M-01, CA3-CBLFX/5M-01)

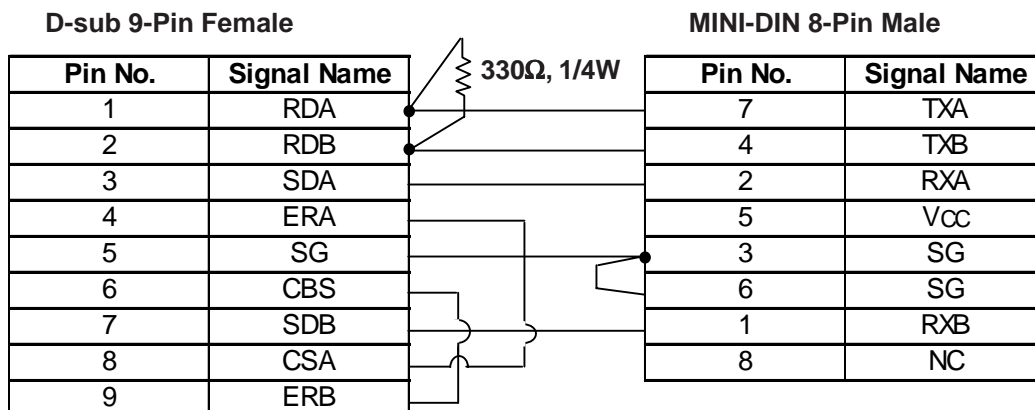

## ■ 2-Port Adapter II (GP070-MD11)

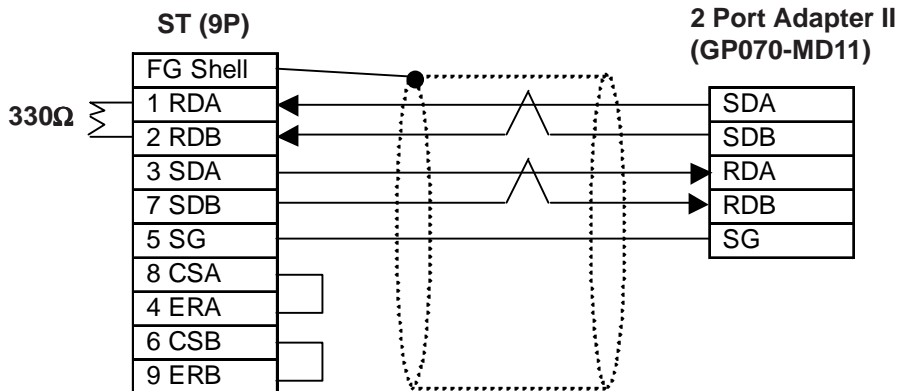

Select the “2-Port Feature | CPU Direct” menu’s “Adapter + GPH” feature.

**Reference** “2-1-5 2-Port Feature”

## ■ 9-Pin <-> 25-Pin Conversion Adapter

When using the PLC manufacturer’s cable with a RS232 connection, if the ST side of the cable uses a 25-pin connector, be sure to attach a RS232C 9-Pin <-> 25-Pin Conversion Adapter.

Commercial-type straight conversion adapter  
9-Pin Female<-> 25-Pin Male

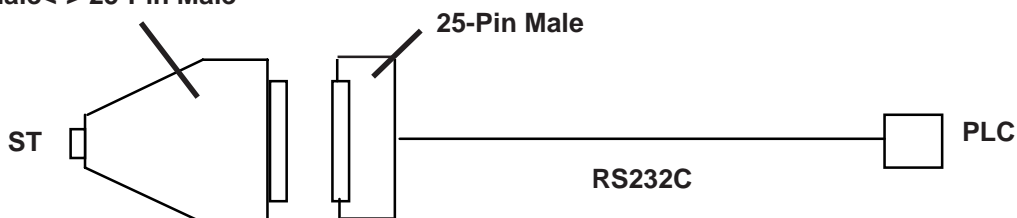

## D-sub 25-Pin Male <-> D-sub 9-Pin Female Conversion Adapter Pin Assignments

