

GP-4402WW/GP-4502WW Installation Guide

GP-4402WW/GP-4502WW 安装指南



http://www.proface.co.in/

A IMPORTANT INFORMATION / 重要信息

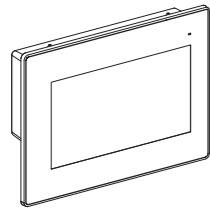

Please read the "Warning/Caution Information" on the attached sheet before using the product. The information provided in this documentation is only for simple installation instruction. Complete general specifications, installation, maintenance and safety instructions are described in the product Hardware Manual. You can download the manual from our website.

使用该产品前，请先阅读附页上的“警告/注意信息”。此文档中提供的信息仅仅是简单安装说明。完整的产品规格，安装，维护以及安全指南等信息，请参考产品《硬件手册》。您可以从我们的网站下载手册。

B PACKAGE CONTENTS / 装箱物品

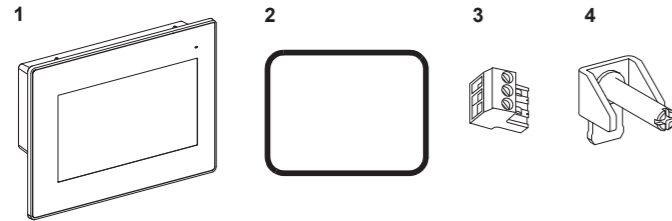

1. GP-4402WW (PFXGP4402WADW) or GP-4502WW (PFXGP4502WADW) x 1
2. Installation Gasket (attached to the panel) / 防水橡皮垫圈 (连接到面板) x 1
3. DC power connector / 直流电源连接器 x 1
4. Screw installation fasteners / 螺钉安装扣件 (GP-4402WW x 4, GP-4502WW x 6)
5. Installation Guide (this guide) / 安装指南 (本指南) x 1
6. Warning/Caution Information x 1

NOTE: Check all the applicable items listed here, if anything was broken please contact your supplier. 请检查包装内各项物品，如有任何损坏请联系您的供货经销商。

C INSTALLATION / 安装说明

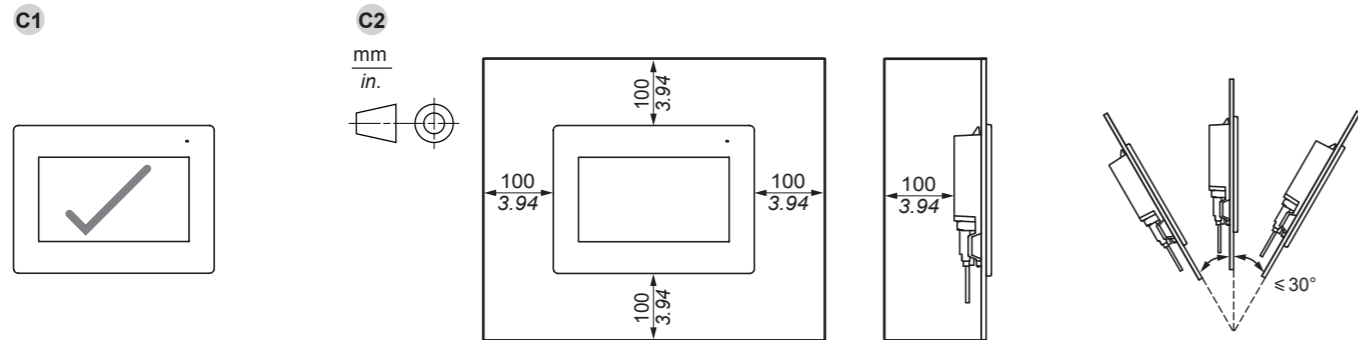

Ambient operating temperature (cabinet interior & panel face) 环境工作温度 (机柜内部和面板表面)	0...50 °C (32...122 °F)
Storage temperature / 存储温度	-20...60 °C (-4...140 °F)
Relative humidity / 相对湿度	<90 % Non condensing / 无冷凝
Pollution degree / 污染等级	2
Atmospheric pressure / 大气压力	800...1,114 hPa (2,000 m [6,561 ft] or lower / 或更低)

⚠️ DANGER / 危险

HAZARD OF ELECTRIC SHOCK, EXPLOSION OR ARC FLASH

- Disconnect all power from all equipment including connected devices, prior to removing any covers or doors, or installing or removing any accessories, hardware, cables, or wires except under the specific conditions specified in the appropriate hardware guide for this equipment.
- Always use a properly rated voltage sensing device to confirm the power is off where and when indicated.
- Replace and secure all covers, accessories, hardware, cables, and wires and confirm that a proper ground connection exists before applying power to the unit.
- Use only the specified voltage when operating this equipment and any associated products.

Failure to follow these instructions will result in death or serious injury.

电击、爆炸或电弧危险

- 在卸除任何护盖或门，或安装或卸除任何附件，硬件，电缆或导线之前，先断开所有设备的电源连接（包括已连接设备），但本设备相应硬件指南中指定的特定情况除外。
- 始终使用合适的额定电压传感器确认所有电源已在指示位置及指示时间关闭。
- 更换并紧固所有壳盖，附件，硬件，电缆与导线，并确认接地连接正确后才对设备通电。
- 在操作本设备及相关产品时，必须使用指定电压。

如不遵守本说明，将可能会导致人员死亡或重伤。

- (en)** Electrical equipment should be installed, operated, serviced, and maintained only by qualified personnel.
- If the equipment is used in a manner not specified by the manufacturer, the protection provided by the equipment may be impaired.
- (zh)** 电器设备的安装，操作，维修和维护工作仅限于合格的人员执行。
- 如果不依照制造商规定的方式使用设备，设备所提供的保护可能会削弱。

NOTE: Please be aware that Digital Electronics Corporation shall not be held liable by the user for any damages, losses, or third party claims arising from the uses of this product. Digital Electronics Corporation 对用户使用该产品所引起的伤害，损失以及所引发的第三方要求，本公司概不承担，敬请谅解。

Copyright © 2016.11 Digital Electronics Corporation. All rights reserved.

Installation Requirements

This product is designed for use on flat surfaces of Type 1 enclosure or IP65. Be aware of the following when building this product into an end-use product:
 • The rear face of this product is not approved as an enclosure. When building this product into an end-use product, be sure to use an enclosure that satisfies standards as the end-use product's overall enclosure.
 • Install this product in an enclosure with mechanical rigidity.
 • This product is not designed for outdoor use. UL certification obtained is for indoor use only.
 • Install and operate this product with its front panel facing outward.
 NOTE: IP65 is not part of the UL certification.

安装需求

此产品适合在类型 1 机柜 或 IP65 的平面上使用。将此产品集成到终端使用产品时注意以下事项
 • 此产品的后面不宜用作外层防护。将此产品集成到终端产品时，务必符合标准的机柜用作终端产品的整体机柜。
 • 将本产品安装在具有足够机械强度的机柜中。
 • 本产品不适合在户外使用。获得的UL认证仅限室内使用。
 • 安装和操作本产品时使其前面板朝外。
 注：IP65 不是UL认证的一部分。

C3 Installation cut-out / 安装开孔尺寸

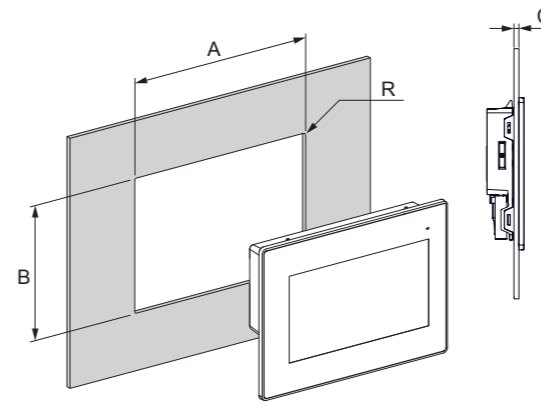

C4 Insert the installation fasteners, then tighten with a Phillips screwdriver / 插入安装扣件并使用十字螺丝刀拧紧

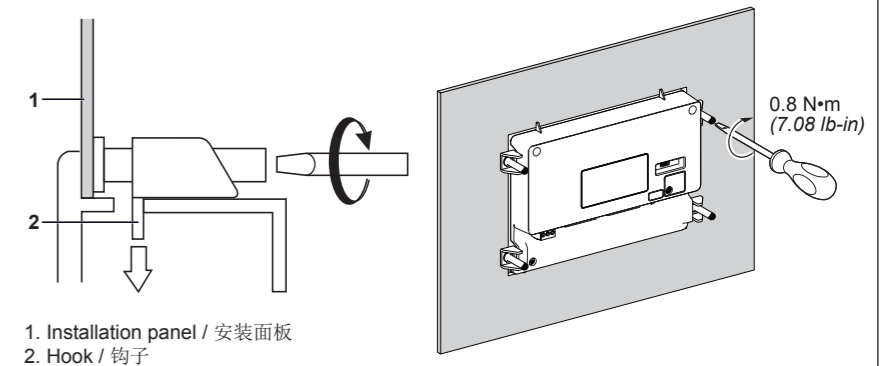

Model / 型号	A	B	C (Panel thickness / 安装面板厚度)	R
GP-4402WW	190 ±1 mm (7.48 ±0.04 in)	135 ±0.7 mm (5.31 ±0.03 in)	1...5 mm (0.04...0.19 in)	3 mm (0.12 in) max.
GP-4502WW	255 ±1 mm (10.04 ±0.04 in)	185 ±1 mm (7.28 ±0.04 in)	1...5 mm (0.04...0.19 in)	3 mm (0.12 in) max.

Model / 型号	Screw Installation Fasteners 螺钉安装扣件
GP-4402WW	4
GP-4502WW	6

NOTICE / 注意

BROKEN ENCLOSURE

Do not exert more than 1 N•m (8.85 lb-in) of torque when tightening the fastener's screws.

Failure to follow these instructions can result in equipment damage.

外壳破损

请不要使用超过 1 N•m (8.85 lb-in) 的力来拧紧螺钉扣件

如果未能遵守本说明，可能会导致设备损坏。

D INTERFACE AND WIRING / 接口和接线说明

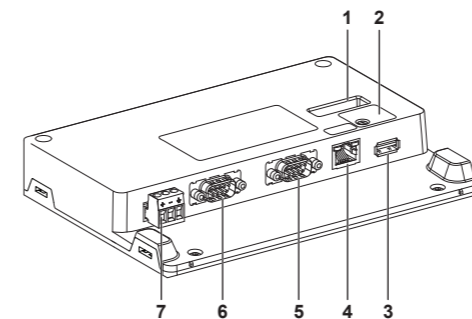

1. USB mini B downloading port / USB mini B 下载接口
2. USB Type A extension port locker / USB Type A 扩展口紧固锁扣
3. USB Type A Extension port / USB Type A 扩展口
4. Ethernet port / 以太网接口
5. Serial Interface RS-422/485 / 串行口 RS-422/485
6. Serial Interface RS-232C / 串行口 RS232C
7. Power supply connector / 电源端子

NOTE: Use only the SELV (Safety Extra-Low Voltage) circuit to connect the COM, USB, and LAN interfaces. 注：只使用安全特低电压 (SELV) 电路连接 COM、USB 和 LAN 接口。

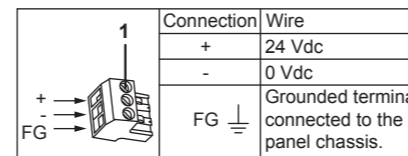

1 Mounting screws / 安装螺钉

Connection	Wire
+	24 Vdc
-	0 Vdc
FG	Grounded terminal connected to the panel chassis.

Pin Connection	Pin	RS-232	RS-422/RS-485
1	CD	RDA	
2	RD(RXD)	RDB	
3	SD(TXD)	SDA	
4	ER(DTR)	-	
5	SG	SG	
6	DR(DSR)	-	
7	RS(RTS)	SDB	
8	CS(CTS)	-	
9	Reserved	-	
Shell	FG	FG	

Pin Connection	Pin	Signal
1	TD+	
2	TD-	
3	RD+	
4	-	
5	-	
6	RD-	
7	-	
8	-	

SG: Signal Ground
FG: Functional Ground

Tighten the mounting screws using the defined torque: 0.5 N•m (4.42 lb-in).

Wherever possible, use wires that are 0.75 to 2.5 mm² (AWG 18 - 12) for the power cord, and twist the wire ends before attaching the terminals.

以定义的扭矩拧紧安装螺钉：0.5 N•m (4.42 lb-in)。

请尽可能使用 0.75 至 2.5 mm² (AWG 18 - 12) 规格的电线用作电源线，并且在连接到设备之前，请先把电缆末端绞合。

NOTICE / 注意

EQUIPMENT DAMAGE

- Only use 24 Vdc to power on the panel.
- Do not share the power supply together with inductive load (magnet valve or magnet switch) or I/Os of controller. 24 Vdc output from some controllers do not have the capacity of current to power the panel

Failure to follow these instructions can result in equipment damage.

设备损坏

- 只允许 24 Vdc 电源供电。
- 不要和感性负载（如电磁阀或电磁开关）或控制器的输入输出电路共享同一个电源。某些控制器上提供的 24 Vdc 输出不能提供足够的电流供面板正常启动。

如果未能遵守本说明，可能会导致设备损坏。

E OPERATION AND MAINTENANCE / 操作和维护

E1 Locking the USB / 锁紧 USB

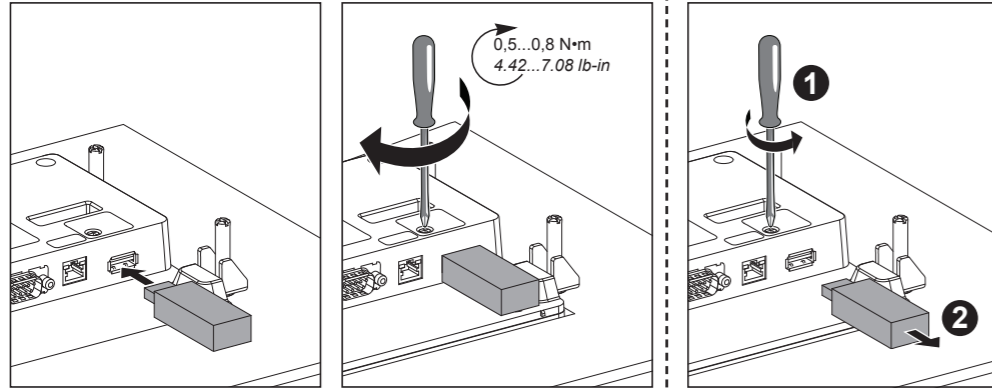

E2 Releasing the battery / 更换电池

⚠ DANGER / 危险

EXPLOSION, FIRE, OR CHEMICAL HAZARD

Follow these instructions for the lithium batteries:

- Use this product's replacement battery only.
- Remove all replaceable batteries before discarding panel.
- Recycle or properly dispose of used batteries.
- Protect battery from any potential short circuit.
- Do not recharge, disassemble, heat above 80 °C (176 °F).
- Use your hands or insulated tools to remove or replace the battery.
- Maintain proper polarity when inserting and connecting a new battery.

Failure to follow these instructions will result in death or serious injury.

存在爆炸、火灾或化学危险

请遵循以下有关锂电池的使用说明:

- 仅可使用本产品的备用电池。
- 丢弃面板之前，请卸除所有可更换的电池。
- 请循环利用或妥善处理用过的电池。
- 防止电池发生任何可能的短路。
- 请勿将电池再充电，拆卸，加热至 80 °C (176 °F) 以上。
- 请务必用手或绝缘工具卸除或更换电池。
- 在插入和连接新电池时，请注意极性的正确放置。

如不遵守本说明，将可能会导致人员死亡或重伤。

Insert a new battery in the compartment in accordance with the polarity markings in the compartment and on the battery.
按照电池舱中和电池上的电极标记在电池舱中插入新电池。

Use only the replacement battery (model number: PFXZGEBT1).
仅可使用备用电池 (型号: PFXZGEBT1)。

Proposed battery maintenance period is 3 years.
建议电池更换周期 3年。

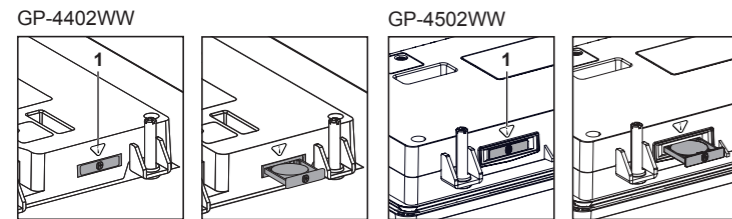

1. Safety alert symbol (see the safety messages above) / 安全警告符号 (请参照上面的安全消息)

E3 Cleaning the Unit / 清洁此产品

NOTICE / 注意

EQUIPMENT DAMAGE

- Power off the unit before cleaning it.
- Do not use hard or pointed objects to operate the touch panel.
- Do not use paint thinner, organic solvents, or a strong acid compound to clean the unit.

Failure to follow these instructions can result in equipment damage.

设备损坏

- 清洁设备前请将其关闭。
- 请勿使用坚硬或尖锐的物件点击触摸屏进行操作。
- 请勿使用稀料，有机溶剂或强酸性化合物清洁该单元。

如果未能遵守本说明，可能会导致设备损坏。

When the unit gets dirty, soak a soft cloth in water with a neutral detergent, wring the cloth tightly and wipe the unit.
若产品变脏，请将软布泡入水中，加入中性清洁剂，再将布拧干后擦拭本产品。

F PRECAUTIONS / 注意事项

After checking the wiring route carefully, make sure to use this product with FG connected.
请仔细确认配线，务必确保FG连接。

Use SELV (Safety Extra-Low Voltage) circuit and LIM (Limited Energy) circuit for DC input.
使用直流电时，请使用安全特低电压 (SELV) 电路和限能 (LIM) 电路。

Grounding

- Use an exclusive grounding with a grounding resistance of 100 Ω or less and a wire of 2 mm² (AWG 14) or thicker, or your country's applicable standard.
- 接地
• 请使用接地阻抗在 100 Ω 或以下的专用地，线径为 2 mm² (AWG 14) 或更粗的接地线，或按照您当地标准。

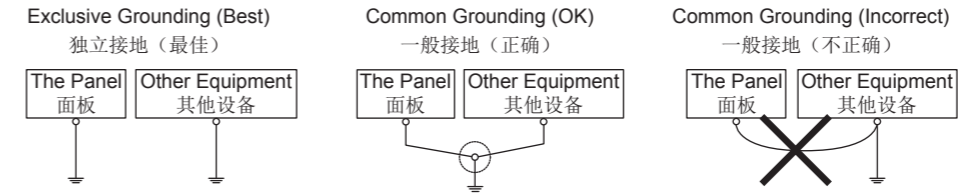

G PRECAUTION FOR LONG AND SAFE USE WITHOUT ANY BREAKDOWNS / 为长期、安心、无故障使用，敬请注意一下事项



No touch with sharp objects
请勿用锐利物体操作



No sunlight/Ultraviolet
请避免阳光或紫外光照射



No touch with excessive pressure
请勿用过大的力操作



No chemical cleanser
请勿接触化学清洁剂

H CHINA RoHS INFORMATION / 中国 RoHS 相关资料

15 部件名称 Part Name	有害物质 Hazardous Substances					
	铅 (Pb)	汞 (Hg)	镉 (Cd)	六价铬 (Cr (VI))	多溴联苯 (PBB)	多溴二苯醚 (PBDE)
金属部件 Metal parts	○	○	○	○	○	○
塑料部件 Plastic parts	○	○	○	○	○	○
电子件 Electronic	×	○	○	○	○	○
触点 Contacts	○	○	○	○	○	○
线缆和线缆附件 Cables & cabling accessories	○	○	○	○	○	○

本表格依据 SJ/T 11364 的规定编制。
○: 表示该有害物质在该部件所有均质材料中的含量均在 GB/T 26572 规定的限量要求以下。
×: 表示该有害物质至少在该部件的某一均质材料中的含量超出 GB/T 26572 规定的限量要求。
This table is made according to SJ/T 11364.
○: Indicates that the concentration of hazardous substance in all of the homogeneous materials for this part is below the limit as stipulated in GB/T 26572.
×: Indicates that concentration of hazardous substance in at least one of the homogeneous materials used for this part is above the limit as stipulated in GB/T 26572.