

Pro-face®

ST3000 Series
Hardware Manual

Preface

Thank you for purchasing Pro-face's ST3000 Series Programmable Operator Interface (Hereafter referred to as the "ST unit").

Before operating your ST unit, be sure to read this manual to familiarize yourself with the ST unit's operation procedures and features.

NOTICE

1. Copying this manual's contents, either in whole or in part, is prohibited without the express permission of Digital Electronics Corporation, Japan.
2. The information contained in this manual is subject to change without notice.
3. If you find any errors or omissions in this document, please contact Digital Electronics Corporation to report your findings.
4. Regardless of Clause 3 above, Digital Electronics Corporation shall not be held responsible for any damages, losses or third-party damages resulting from the use of this product.

© 2006 Copyright Digital Electronics Corporation. All rights reserved.





Product names used in this manual are the trademarks / registered trademarks of their respective owners.

Essential Safety Precautions

All safety-related procedures stated in this document must be followed to operate the ST correctly and safely. Be sure to read this and any related documents thoroughly to understand the correct operation and functions of the ST unit.





Safety Icons

Throughout this manual, these icons provide essential safety information for ST operation procedures requiring special attention. These icons indicate the following levels of danger:

 WARNING	Indicates situations where severe bodily injury, death or major equipment damage can occur.
 CAUTION	Indicates situations where slight bodily injury or minor equipment damage can occur.
	Indicates actions or procedures that should NOT be performed.
	Indicates actions or procedures that MUST be performed to ensure correct unit operation.

WARNING

System Design

-  Do not create ST touch panel switches that could possibly endanger the safety of personnel or equipment. A malfunction of the ST unit, its I/O unit(s), cable(s), or other related equipment can cause unexpected output signals, leading to a serious accident. Be sure to design all important machine operation switches so they are operated via a separate control system, and not via the ST.
-  Do not create ST touch panel switches to control machine safety operations, such as an emergency stop switch. Install these switches as separate hardware switches, otherwise severe bodily injury or equipment damage can occur.
-  Be sure to design your system so that a communication fault between the ST and its host controller will not cause equipment to malfunction. This is to prevent any possibility of bodily injury or equipment damage.
-  Do not use the ST as a warning device for critical alarms that can cause serious operator injury, machine damage or can halt system operation. Critical alarm indicators and their control/activator units must be designed using stand-alone hardware and/or mechanical interlocks.
-  Do not use the ST with aircraft control devices, aerospace equipment, central trunk data transmission (communication) devices, nuclear power control devices, or medical life support equipment, due to these devices' inherent requirements of extremely high levels of safety and reliability.

- ❗ When using the ST with transportation vehicles (trains, cars, and ships), disaster and crime prevention devices, various types of safety equipment, and medical devices that are not life-support related, use redundant and/or failsafe system designs to ensure proper reliability and safety.
- ⊘ After the ST unit's backlight burns out the touch panel is still active, unlike the ST unit's "Standby Mode". If the operator fails to notice that the backlight is burned out and touches the panel, a potentially dangerous machine operation error can occur. Therefore, do not create ST unit touch panel switches that may cause injury and/or equipment damage. If your ST unit's backlight suddenly turns OFF, use the following steps to determine if the backlight is actually burned out.
 - 1) If the ST unit's "Backlight Control" is not set and the screen has gone blank, your backlight is burned out.
 - 2) If the ST unit's "Backlight Control" is set to Standby Mode and the screen has gone blank, and touching the screen or performing another input operation does not cause the display to reappear, your backlight is burned out.

Handling

- ⊘ Do not modify the ST unit. Doing so may cause a fire or an electric shock.
- ⊘ Do not operate the ST in an environment where flammable gases are present, since it may cause an explosion.

Wiring

- ❗ To prevent an electric shock be sure to disconnect your ST unit's power cord from the power supply before wiring the ST.
- ⊘ Do not use voltage beyond the ST unit's specified range. Doing so may cause a fire or an electric shock.

Maintenance

- ⊘ Do not connect or disconnect Host and ST unit communication cables while the ST is turned ON.
- ⊘ Do not replace the ST unit's battery yourself. The ST uses a lithium battery for backing up its internal clock data and the battery may explode if it is replaced incorrectly. When replacement is required, please contact your local ST distributor.

CAUTION

Installation

- ❗ Be sure all cable connectors are securely attached to the ST unit. A loose connection may cause incorrect input or output signals.

Wiring

- ❗ Be sure to ground the ST unit's FG wire separately from other equipment FG lines. Also, be sure to use a grounding resistance of 100 or less and a 2mm² or thicker wire, or your country's applicable standard. Otherwise, electric shock or malfunctions may result.
- ❗ Be sure to use only the designated torque to tighten the ST unit's terminal block screws. If these screws are not tightened firmly, it may cause a short-circuit, fire or incorrect unit operation.
- ❗ Be sure that metal particles and wiring debris do not fall inside the ST unit. They can cause a fire, malfunction or incorrect unit operation.

Maintenance

- ⊘ Be sure to turn the ST unit's CF Card ACCESS switch OFF and confirm that the ACCESS lamp is not lit prior to inserting or removing a CF Card. Otherwise, CF Card internal data may be damaged or lost.
- ⊘ Do not reset or turn the ST OFF, or insert or remove the CF Card while the ST unit's CF Card is being accessed. Create special application screens to perform operations like turning power OFF, resetting the ST or inserting or removing the CF Card.

Unit Disposal

- ❗ When the product is disposed of, it should be done so according to your country's regulations for similar types of industrial waste.

General Safety Precautions

- ⊘ Do not press on the ST unit's display with excessive force or with a hard object, since it can damage the display. Also, do not press on the touch panel with a pointed object, such as the tip of a mechanical pencil or a screwdriver, since doing so can damage the touch panel.
- ⊘ Do not install the ST where the ambient temperature exceeds the specified range. Doing so may cause a unit malfunction.
- ⊘ To prevent abnormally high temperatures from occurring inside the ST, do not restrict or block the ST unit's rear-face ventilation slots.
- ⊘ Do not operate the ST in areas where large, sudden temperature changes can occur. These changes can cause condensation to form inside the ST, possibly causing it to malfunction.

- ⊘ Do not allow water, liquids or metal fragments to enter inside the ST unit's case, since they can cause either a malfunction or an electric shock. The allowable pollution degree is 2.
- ⊘ Do not operate or store the ST in locations where it can be exposed to direct sunlight, high temperatures, excessive dust, moisture or vibration.
- ⊘ Do not operate or store the ST where chemicals evaporate, or where chemicals are present in the air.
Corrosive chemicals: Acids, alkalines, liquids containing salt
Flammable chemicals: Organic Solvents
- ⊘ Do not use paint thinner or organic solvents to remove dirt or oil from the ST unit's surface. Instead, use a soft cloth moistened with a diluted neutral detergent.
- ⊘ Do not use or store the ST in areas with direct sunlight, since the sun's ultraviolet rays may cause the LCD's quality to deteriorate.
- ❗ Do not store the ST in an area where the temperature is lower than that recommended in the ST unit's specifications. Doing so may cause the LCD display's liquid to congeal, which can damage the LCD.



Also, if the storage area's temperature becomes higher than the specified level, the LCD's liquid may become isotropic, causing irreversible damage to the LCD. Therefore, only store the ST in areas where temperatures are within the ST unit's specifications.
- ❗ After turning OFF the ST, be sure to wait a few seconds before turning it ON again. The ST may not operate correctly if it is restarted too quickly.
- ❗ Due to the possibility of unexpected accidents, be sure to back up the ST unit's data regularly.

LCD Panel Usage Precautions

- The LCD panel's liquid contains an irritant. If the panel is damaged and any of this liquid contacts your skin, immediately rinse the area with running water for at least 15 minutes. If the liquid gets in your eyes, immediately rinse your eyes with running water for at least 15 minutes and consult a doctor.
- The ST unit's LCD screen may flicker or show unevenness in the brightness of certain images or at some contrast settings. This is an LCD characteristic and not a product defect.
- There's an individual difference in brightness and tone of LCD screen. Please be aware of this difference before using the lined-up plural units.
- Depending on the ambient temperature, LCD screens may sometimes look whitish (at high temperatures) or blackish (at low temperatures). This is an LCD characteristic and not a product defect.
- Some of ST unit's LCD screens may contain light or dark pixels. This is an LCD characteristic and not a product defect.
- Extended shadows, or "Crosstalk" may appear on the sides of screen images. This is an LCD characteristic and not a product defect.
- The color displayed on the ST unit's LCD screen may appear different when seen from outside the specified viewing angle. This is an LCD characteristic and not a product defect.
- When the same image is displayed on the ST unit's screen for a long period, an afterimage may appear when the image is changed. If this happens, turn off the ST, wait 10 seconds and then restart the unit. This is an LCD characteristic and not a product defect.
- To prevent an afterimage:
 - * Set the ST unit's display OFF feature when you plan to display the same screen image for a long period of time.
 - * Change the screen image periodically and try to not display the same image for a long period of time.

Information Symbols

This manual uses the following icons:

	Indicates a warning or a product limitation. Be sure to follow the instructions given with this icon to ensure the safe operation of the ST.
Screen Editor	Indicates the GP-Pro EX software.
PLC	Abbreviation for Programmable Logic Controller.
*	Indicates useful or important supplemental information.
	Contains additional or useful information.
	Indicates pages containing related information.

ST3000 Series Model Name Indication

Model name

A **ST** **3** ***** ***** ***** **-** ***** **1** **-** ***** ***** *****
A B C D

A	2	ST-3200 series (3.8-inch): QVGA (320 x 240 dots)
	3	ST-3300 series (5.7-inch): QVGA (320 x 240 dots)
	4	ST-3400 series (7.5-inch): VGA (640 x 480 dots)
	5	ST-3500 series (10.4-inch): VGA (640 x 480 dots)
B	01	ST3000 series SIO type
	11	ST-3200 series MPI type
	02	ST-3300 series MPI type
C	A	Monochrome Amber/Red LCD
	B	Monochrome blue mode LCD
	C	Color LCD
	S	STN color LCD
	T	TFT color LCD
D	D24	DC type power supply is used.
	AF	AC type power supply is used.







ST3000 Series Model Names

The term “ST3000” Series refers to the following ST model numbers:

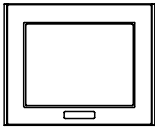
Series		Model	Product number
ST3000 series	ST-3200 series	AST-3201A	AST3201-A1-D24
		AST-3211A (MPI)	AST3211-A1-D24
	ST-3300 series	AST-3301B	AST3301-B1-D24
		AST-3301S	AST3301-S1-D24
		AST-3301T	AST3301-T1-D24
		AST-3302B (MPI)	AST3302-B1-D24
	ST-3400 series	AST-3401T	AST3401-T1-D24
	ST-3500 series	AST-3501C	AST3501-C1-D24
			AST3501-C1-AF
		AST-3501T	AST3501-T1-D24
			AST3501-T1-AF

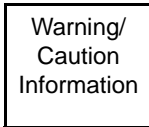
Package Contents

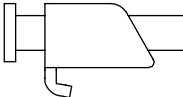
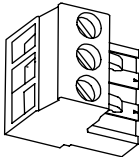
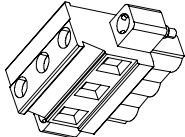
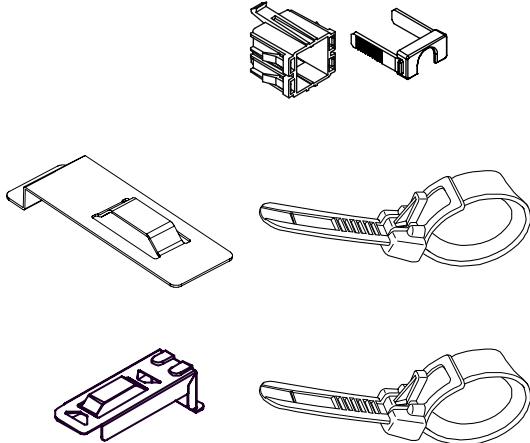
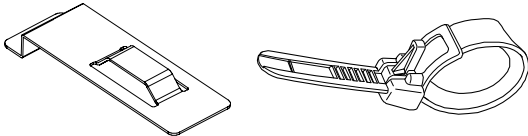
The following items are included in the ST unit's package. Before using the ST, please check that all items listed here are present.

<p>ST Unit: 1</p> 	<p>English and Japanese Installation Guides (One of each)</p> 	<p>Warning/Caution Information: 1</p> 
<p>Installation Gasket: 1 (Attached to the ST unit)</p> 	<p>Installation Fasteners: 4 per set</p> 	
<p>DC Power Connector: 1</p> <ul style="list-style-type: none"> · ST-3200/3300/3400 series (Attached to the ST unit for ST-3200/3300 series) 		<ul style="list-style-type: none"> · ST-3500 series (DC type only) (Attached to the ST unit) 
<p>USB Cable Clamp: 1 set</p> <ul style="list-style-type: none"> · ST-3200/3400 series Holder: 1, Cover: 1 · ST-3300 series Holder: 1, Clamp: 1 · ST-3500 series Holder: 1, Clamp: 1 	  	

This unit has been carefully packed, with special attention to quality. However, should you find anything damaged or missing, please contact your local ST distributor immediately.

UL/c-UL Approval

The following units are UL/c-UL listed products. (UL File No.E220851)

Product Model No.	UL/c-UL Registration Model No.
AST3201-A1-D24	3580205-01
AST3211-A1-D24	3580205-02
AST3301-B1-D24	3580207-02
AST3301-S1-D24	3580207-01
AST3301-T1-D24	3710010-01
AST3302-B1-D24	3710010-02
AST3401-T1-D24	3580206-01
AST3501-C1-D24	3520208-02
AST3501-T1-D24	

This product conforms to the following standards:

- UL508 Industrial Control Equipment
- CSA-C22.2 No.142-M1987 (c-UL Approval) Standard for Process Control Equipment

The following units are UL/c-UL recognized components. (UL File No.E171486)

Product Model No.	UL/c-UL Registration Model No.
AST3501-C1-AF	3580208-01
AST3501-T1-AF	

This product conforms to the following standards:

- UL60950-1 Information Technology Equipment - Safety - Part 1
- CAN/CSA-C22.2 No.60950-1-03 (c-UL approval)
Information Technology Equipment - Safety - Part 1

<Cautions>

Be aware of the following items when building the ST into an end-use product:

- The ST unit's rear face is not approved as an enclosure. When building the ST unit into an end-use product, be sure to use an enclosure that satisfies standards as the end-use product's overall enclosure.
- The ST unit must be used indoors only.
- Install and operate the ST with its front panel facing outwards.
- If the ST is mounted so as to cool itself naturally, be sure to install it in a vertical panel. Also, it's recommended that the ST should be mounted at least 100 mm away from any other adjacent structures or machine parts. The temperature must be checked on the final product in which the ST is installed.
- For use on a flat surface of a Type 4X (Indoor Use Only) and/or Type 13 Enclosure.

CE Marking

The following units are CE marked products complying with the EMC Directive.

They comply with EN55011 Class A, EN61131-2.

AST3201-A1-D24

AST3211-A1-D24

AST3301-B1-D24

AST3301-S1-D24

AST3301-T1-D24

AST3302-B1-D24

AST3401-T1-D24

AST3501-C1-D24

AST3501-T1-D24

The following units are CE marked products complying with both the EMC Directive and low-voltage directive.

They comply with EN55011 Class A, EN61131-2 and EN60950-1.

AST3501-C1-AF

AST3501-T1-AF

About Revision

The nameplate on the ST has the revision code of the ST. In the example below, the asterisk, which is placed at the “A” position, shows that the revision code is “A”.

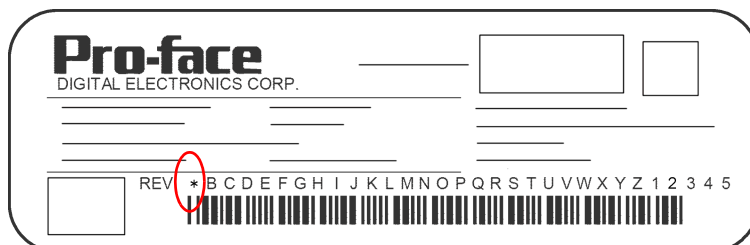

Contents

Preface	1
Essential Safety Precautions.....	2
Information Symbols.....	7
ST3000 Series Model Name Indication.....	8
ST3000 Series Model Names	9
Package Contents	10
UL/c-UL Approval.....	11
CE Marking.....	12
About Revision	12
Contents	13

Chapter 1 Overview

1.1 System Design.....	1-2
1.2 Accessories	1-6

Chapter 2 Part Names and Functions

2.1 ST-3200 Series	2-2
2.2 ST-3300 Series	2-3
2.3 ST-3400 Series	2-4
2.4 ST-3500 Series	2-6

Chapter 3 Specifications

3.1 ST-3200 Series	3-2
3.1.1 General Specifications	3-2
3.1.2 Performance Specifications	3-4
3.1.3 Interface Specifications.....	3-6
3.1.4 Dimensions	3-11
3.2 ST-3300 Series	3-14
3.2.1 General Specifications	3-14
3.2.2 Performance Specifications	3-16
3.2.3 Interface Specifications.....	3-19
3.2.4 Dimensions	3-23
3.3 ST-3400 Series	3-26
3.3.1 General Specifications	3-26
3.3.2 Performance Specifications	3-28
3.3.3 Interface Specifications.....	3-31
3.3.4 Dimensions	3-33

3.4 ST-3500 Series	3-36
3.4.1 General Specifications	3-36
3.4.2 Performance Specifications	3-39
3.4.3 Interface Specifications	3-42
3.4.4 Dimensions	3-45

Chapter 4 Installation and Wiring

4.1 Installation.....	4-2
4.2 Wiring Precautions.....	4-7
4.2.1 Connecting the Power Cord.....	4-7
4.2.2 Connecting the Power Supply.....	4-12
4.2.3 Grounding	4-13
4.2.4 I/O Signal Line Placement	4-14
4.3 CF Card Insertion/Removal	4-15
4.3.1 Inserting the CF Card.....	4-15
4.3.2 Removing the CF Card	4-16
4.3.3 CF Card Handling	4-16
4.4 USB Cable Clamp Attachment/Removal	4-17
4.4.1 When using the ST-3200/3400 series.....	4-17
4.4.2 When using the ST-3300 series.....	4-19
4.4.3 When using the ST-3500 series.....	4-20

Chapter 5 Maintenance

5.1 Cleaning the Display.....	5-2
5.2 Periodic Check Points.....	5-3
5.3 Replacing the Installation Gasket	5-4
5.4 Replacing the Backlight	5-6

1 | Overview

1. System Design
2. Accessories

This chapter describes the peripheral devices that can be connected to the ST Series units.

1.1 System Design

The following diagram illustrates the standard range of items that can be connected to ST3000 Series units. For host controller (PLC, etc.) connection information, refer to the “GP-Pro EX Device/PLC Connection Manual”.

◆ ST RUN Mode Peripherals

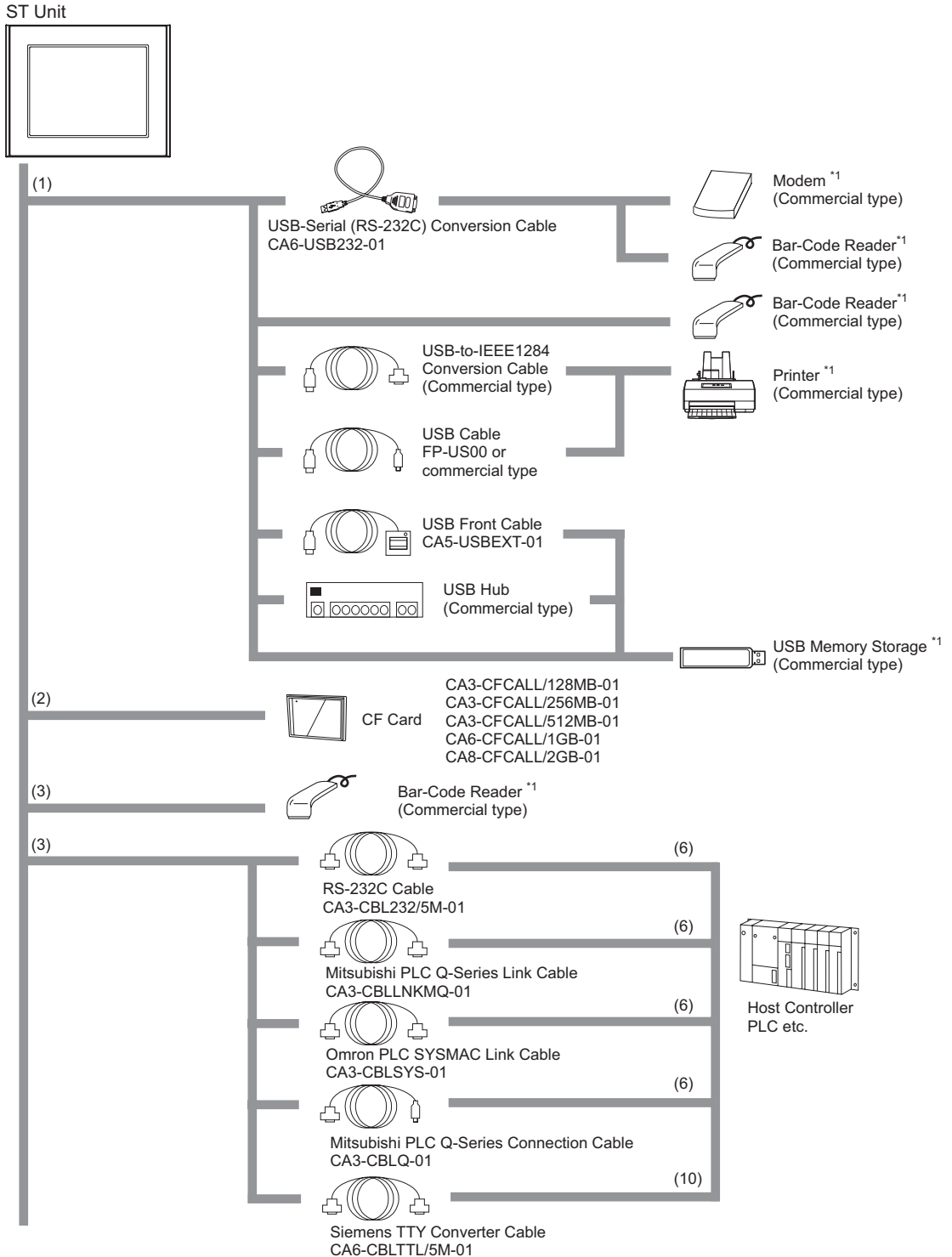

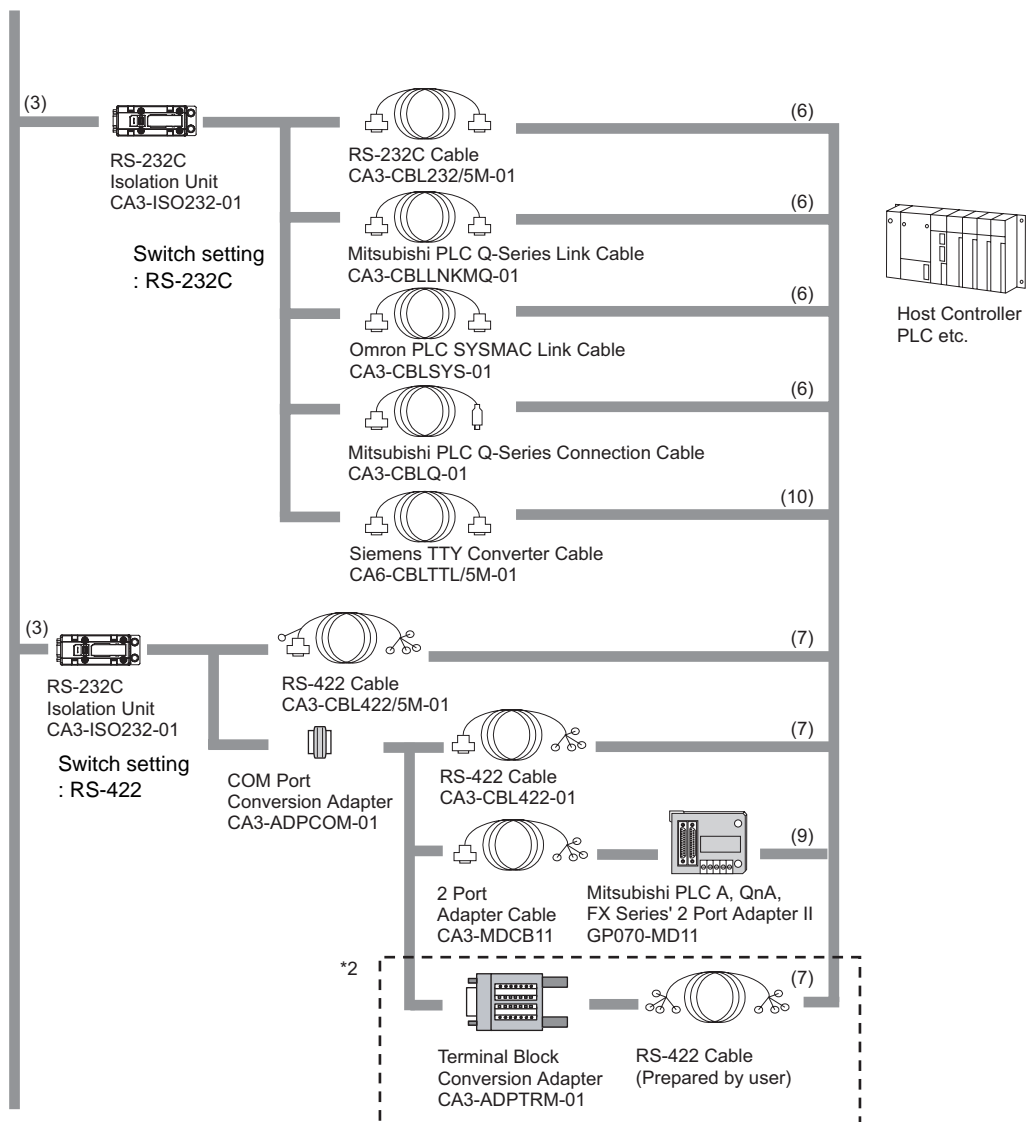
**NOTE**

- When connecting the CA3-ISO232-01, set the 9 Pin connector setting on the COM port to VCC.
COM port settings can be set with the GP-Pro EX or in the ST's offline mode.

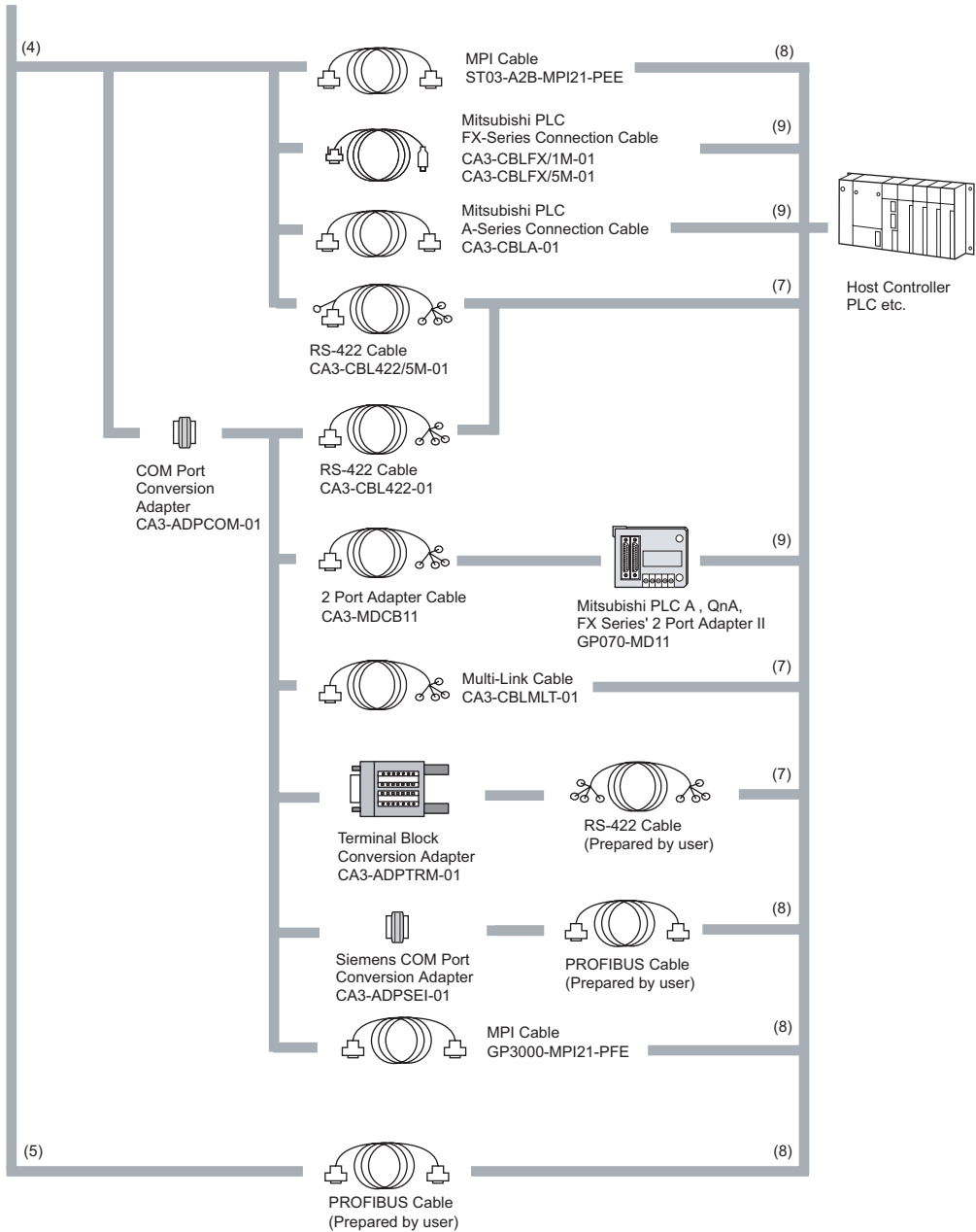

ST Interfaces	PLC Interfaces
(1) USB Host Interface	(6) RS-232C Port
(2) CF Card Interface Only the ST-3400/3500 Series are supported.	(7) RS-422 Port
(3) Serial Interface (COM1)	(8) RS-485 Port
(4) Serial Interface (COM2) (except for AST-3211A and AST-3302B)	(9) Programming Console Port
(5) Serial Interface (COM2) (AST-3211A and AST-3302B only)	(10) PG Port

◆ Edit Mode Peripherals

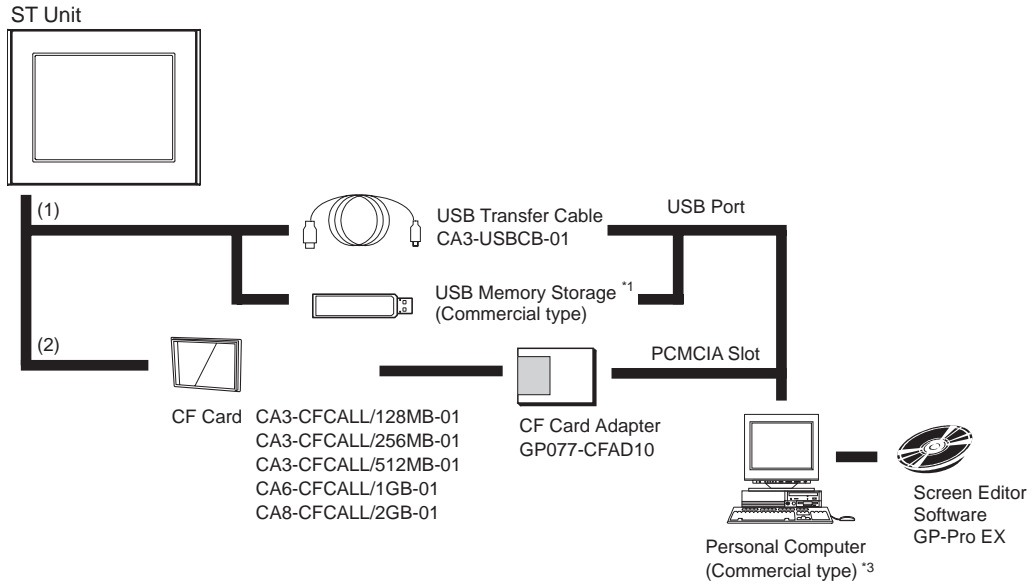

ST Interfaces

- (1) USB Host Interface
- (2) CF Card Interface
(Only ST-3400/3500 series are supported.)

*1 For supported models, refer to Pro-face's support site "Otasuke Pro!" (<http://www.pro-face.com/otasuke/>). You can connect to this site by clicking the GP-Pro EX's [Help (H)] menu - [Connect to Support Site-"Otasuke Pro!" (C)] command.

*2 Use only the four-wire one-to-one connection type.

*3 Certain types and models of PCs cannot be used.

SEE → *GP-Pro EX Reference Manual*

1.2 Accessories

All accessories listed here are produced by Pro-face.

■ Serial Interface Item

Product Name	Model No.	Description
RS-232C Cable	CA3-CBL232/5M-01 (5m)	Connects Mitsubishi PLC A-Series (or other host controller) to the ST. (RS-232C)
RS-422 Cable	CA3-CBL422/5M-01 (5m)	Connects a host controller to the ST. (RS-422)
Mitsubishi PLC Q-Series Link Cable	CA3-CBLLNKM-01 (5m)	Connects Mitsubishi PLC Q-Series (or other host controller) to the ST. (RS-232C)
Omron PLC SYSMAC Link Cable	CA3-CBLSYS-01 (5m)	Connects Omron PLC SYSMAC Series unit (or other host controller) to the ST. (RS-232C)
Mitsubishi PLC A-Series Connection Cable	CA3-CBLA-01 (5m)	Connects Mitsubishi PLC A, QnA Series programming console I/F to the ST. (Simultaneous use of programming console is not possible.)
Mitsubishi PLC Q-Series Connection Cable	CA3-CBLQ-01 (5m)	Connects Mitsubishi PLC Q-Series programming console I/F to the ST. (Simultaneous use of programming console is not possible.)
Mitsubishi PLC FX-Series Connection Cable	CA3-CBLFX/1M-01 (1m) CA3-CBLFX/5M-01 (5m)	Connects Mitsubishi PLC FX-Series programming console I/F to the ST. (Simultaneous use of programming console is not possible.)
9-pin-to-25-pin RS-232C Conversion Cable	CA3-CBLCBT232-01 (0.2m)	The cable that connects the D-Sub 9-pin plug to D-Sub 25-pin socket.
9-pin-to-25-pin RS-422 Conversion Cable	CA3-CBLCBT422-01 (0.2m)	The cable that connects the D-Sub 9-pin socket to D-Sub 25-pin socket.
RS-422 Cable	CA3-CBL422-01 (5m)	Connects a host controller to the ST. (RS-422)
2 Port Adapter Cable	CA3-MDCB11 (5m)	Connects Mitsubishi PLC to the ST using 2 port adapter II (RS-422).
Mitsubishi PLC A, QnA, FX Series 2 Port Adapter II	GP070-MD11	Allows simultaneous use of an ST Series unit and a Mitsubishi PLC A, QnA, FX Series peripheral device.
Multi-Link Cable	CA3-CBLMLT-01 (5m)	Connects a host controller to the ST for multi-link (n:1) communication.
Terminal Block Conversion Adapter	CA3-ADPTRM-01	Connects output from a serial interface with an RS-422 terminal block.
COM Port Conversion Adapter	CA3-ADPCOM-01	Connects optional RS-422 communication items to the ST unit's COM1 port.
Siemens COM Port Conversion Adapter	CA3-ADPSEI-01	Connects Siemens PLCs to the ST. (for RS-485 communication)
Siemens TTY Converter Cable	CA6-CBLTTL/5M-01 (5m)	Connects Siemens PLC S5 Series to the ST.

Continued

Product Name	Model No.	Description
MPI Cable	ST03-A2B-MPI21-PFE (3.5m) GP3000-MPI21-PFE (3.5m)	The interface cable that establishes MPI-communication between each of the hosts and the ST3000 Series.
RS-232C Isolation Unit	CA3-ISO232-01	Connects a host controller to the ST and provides isolation. RS-232C / RS-422 switching unit.

■ USB Host Interface

Product Name	Model No.	Description
USB Transfer Cable	CA3-USBCB-01 (2m)	Downloads project data created with the Screen Editor via the ST unit's Serial I/F.
USB Cable	FP-US00 (5m)	Connects a USB printer. (TYPE-B)
USB Front Cable	CA5-USBEXT-01 (1m)	Extension cable attaching USB port to front panel.
USB-Serial (RS-232C) Conversion Cable	CA6-USB232-01 (0.5m)	The conversion cable for using a ST's USB I/F as the Serial I/F (RS-232C). Connects a Modem ^{*1} or a Bar-cord Reader ^{*1} for the RS-232C communication method.

*1. For supported models, refer to Pro-face's support site "Otasuke Pro!" (<http://www.pro-face.com/otasuke/>).

You can connect to this site by clicking the GP-Pro EX's [Help (H)] menu - [Connect to Support Site- "Otasuke Pro!" (C)] command.

■ CF Card Items

Only the ST-3400/3500 Series support a CF Card interface.

Product Name	Model No.	Description
CF Card (128MB)	CA3-CFCALL/128MB-01	Inserted into the ST unit's CF Card slot.
CF Card (256MB)	CA3-CFCALL/256MB-01	
CF Card (512MB)	CA3-CFCALL/512MB-01	
CF Card (1GB)	CA6-CFCALL/1GB-01	
CF Card (2GB)	CA8-CFCALL/2GB-01	
CF Card Adapter	GP077-CFAD10	Used for read/write of CF Card data via a PC's PCMCIA slot.

■ Optional Items

Product Name	Model No.	Corresponding ST	Description
Screen Protection Sheet	CA6-DFS4-01	ST-3200 Series	Disposable, dirt-resistant sheet for the ST unit's screen. (5 sheets/set) (Hard type)
	CA3-DFS6-01	ST-3300 Series	
	PS400-DF00	ST-3400 Series	
	CA5-DFS10-01	ST-3500 Series	

■ Maintenance Items

Product Name	Model No.	Corresponding ST	Description
Installation Fastener	CA3-ATFALL-01	ST3000 Series	Used to install the ST into a solid panel.
Installation Gasket	ST400-WP01	ST-3200 Series	Provides dust and moisture resistance when ST is installed into a solid panel.
	CA3-WPG6-01	ST-3300 Series	
	CA5-WPG8-01	ST-3400 Series	
	CA5-WPG10-01	ST-3500 Series	
Connector Cover	CA3-BUSCVR-01	ST-3200 Series ST-3300 Series ST-3400 Series	Protects the ST unit's rear face connector.
USB Cable Clamp (1 port)	CA5-USBATM-01	ST-3300 Series	USB Cable clamp products to prevent disconnection.
USB Cable Clamp (2 port)	CA5-USBATL-01	ST-3200 Series ST-3400 Series	USB Cable clamp products to prevent disconnection.
DC Power Supply Connector for Medium-sized Units	CA5-DCCNM-01	ST-3200 Series ST-3300 Series ST-3400 Series	Connector for attaching power supply to medium-sized units.
DC Power Supply Connector for Large-sized Units	CA5-DCCNL-01	ST-3500 Series	Connector for attaching power supply to large-sized units.
Attachment	CA4-ATM5-01	ST-3300 Series	Panel cutout adapter for mounting ST-3300 series in cutout of GP-37W2B.
	CA4-ATM10-01	ST-3500 Series	Panel cutout adapter for mounting ST-3500 series in cutout of GP-2500/2600 series.

2



Part Names and Functions

1. ST-3200 Series
2. ST-3300 Series
3. ST-3400 Series
4. ST-3500 Series

This chapter describes the names and functions of the ST series components.

2.1 ST-3200 Series

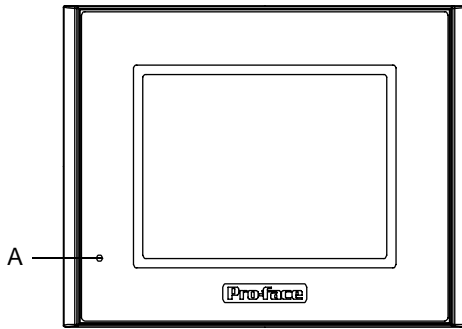

Front

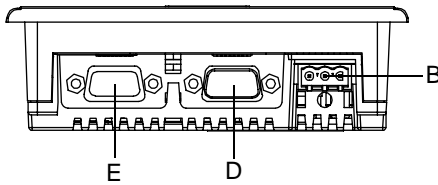

Bottom

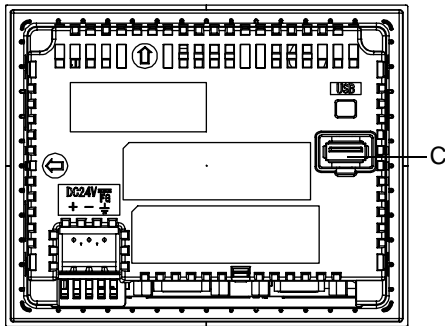

Back

A: Status LED

This LED indicates the ST's status, e.g. power input or firmware RUN status.

LED	ST Operation
Green (lit)	Normal operation (power is ON.) or OFFLINE operation.
Orange (blinking)	During software startup.
Red (lit)	Power is ON.
Not lit	Power is OFF.

B: Power Plug Connector

C: USB Host Interface (USB)

USB 1.1 compliant.

One port for TYPE-A connector.

Power supply voltage: DC5V \pm 5%.

Maximum output current: 500mA

Maximum communication distance: 5m

Interfaces with transfer cable, USB-compatible printer, and other compatible devices.

D: Serial Interface (COM1)

RS-232C serial interface. D-Sub 9-pin plug type connector.

E: Serial Interface (COM2)

AST-3201A:

RS-422/RS-485^{*1} serial interface. D-Sub 9-pin plug type connector.

AST-3211A:

RS-485 (MPI only) serial interface. D-Sub 9-pin socket type connector.

*1 RS-485 is compliant with AST-3201A units with revision code "C" or later.

SEE → About Revision (page 12)

2.2 ST-3300 Series

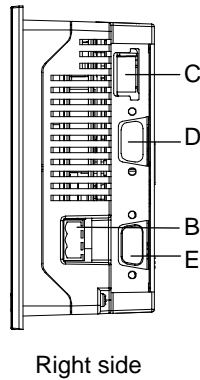
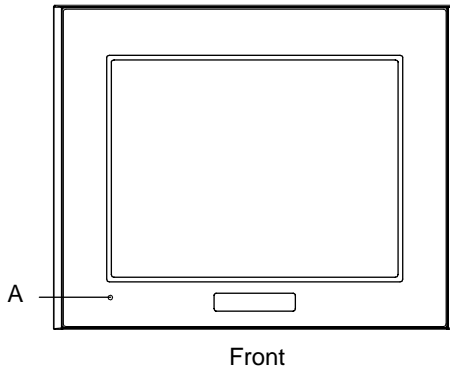

A: Status LED

This LED indicates the ST's status, e.g. power input or firmware RUN status.

LED	ST Operation
Green (lit)	Normal operation (power is ON.) or OFFLINE operation.
Orange (blinking)	During software startup.
Red (lit)	Power is ON.
Not lit	Power is OFF.

B: Power Plug Connector

C: USB Host Interface (USB)

USB 1.1 compliant.

One port for TYPE-A connector.

Power supply voltage: DC5V \pm 5%.

Maximum output current: 500mA

Maximum communication distance: 5m

Interfaces to transfer cable, USB-compatible printer, and other compatible devices.

D: Serial Interface (COM1)

RS-232C serial interface.

D-Sub 9-pin plug type connector.

E: Serial Interface (COM2)

AST-3301B, AST-3301S, AST-3301T:

RS-422/RS-485^{*1} serial interface.

D-Sub 9-pin plug type connector.

AST-3302B:

RS-485 (MPI only) serial interface. D-Sub 9-pin socket type connector.

*1 RS-485 is compliant with AST-3301B / AST-3301S with revision code "B" or later. For all other models, all revisions support RS-485.

2.3 ST-3400 Series

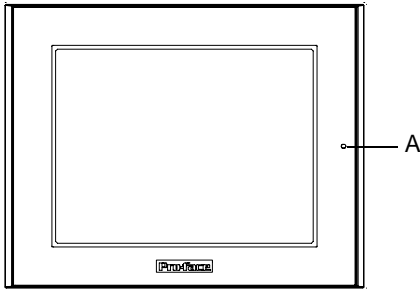

Front

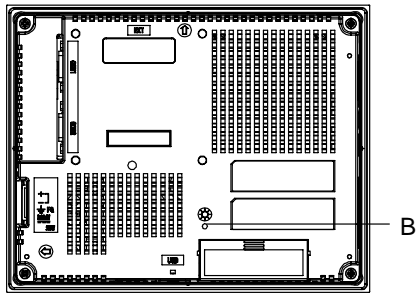

Back

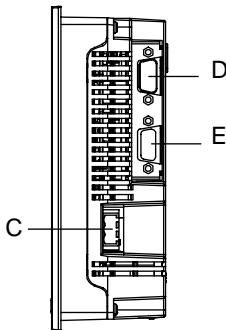

Right side

A: Status LED

This LED indicates the ST's status, e.g. power input or firmware RUN status.

LED	ST Operation
Green (lit)	Normal operation (power is ON.) or OFFLINE operation.
Orange (blinking)	During software startup.
Red (lit)	Power is ON.
Not lit	Power is OFF.

B: CF Card Access Lamp

This lamp light up when CF card is inserted and CF card cover is closed. However, opening the CF card cover, in the CF card while accessing it continues to light up.

Access Lamp	Indicates
Green ON	The CF Card is inserted and the CF Card Cover is closed. Or, the CF Card is being accessed.
Green OFF	The CF Card is not inserted or is not being accessed.

C: Power Plug Connector

D: Serial Interface (COM1)

RS-232C serial interface.
D-Sub 9-pin plug type connector.

E: Serial Interface (COM2)

RS-422/RS-485^{*1} serial interface.
D-Sub 9-pin plug type connector.

*1 RS-485 is compliant with ST-3400 series units with revision code "A" or later.

SEE → About Revision (page 12)

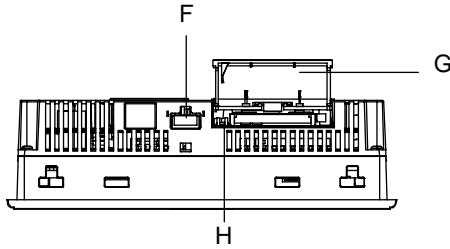

Bottom
(With CF Card Cover open)

F: USB Host Interface (USB)

USB 1.1 compliant.

One port for TYPE-A connector.

Power supply voltage: DC5V \pm 5%.

Maximum output current: 500mA

Maximum communication distance: 5m

Interfaces to transfer cable, USB-compatible printer, and other compatible devices.

G: CF Card Cover

The CF Card I/F and DIP Switches are located in the CF Card Cover opening. This cover must be closed when accessing the CF Card.

H: DIP Switches

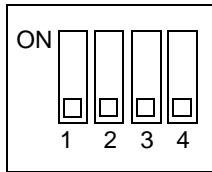

DIP Switches	Function	ON	OFF	Note
1	Start up from CF Card	Enabled	Disabled	CF Card with startup data required
2*	Forced transfer mode	Forced Transfer Mode: ON	Forced Transfer Mode: OFF	-
3	Reserved	-	-	Constantly OFF
4	Simulate cover closed, allowing card to be read even if cover open	Enabled	Disabled	Used when CF Card cover is damaged

* When the unit turns ON with DIP switch 2 ON, the unit starts in transfer mode. Under normal operating conditions, set to OFF.

2.4 ST-3500 Series

The following images of an AST-350IT (AC type) Series unit.

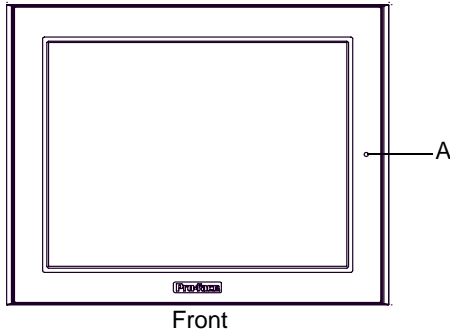

Back

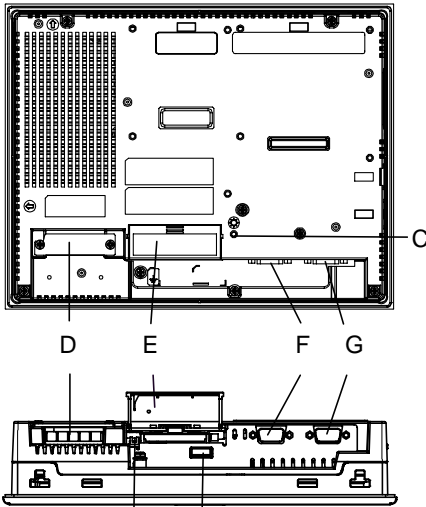

Bottom
(CF-Card Cover Open View)

A: Status LED

This LED indicates the ST's status, e.g. power input or firmware RUN status.

LED	ST Operation
Green (lit)	Normal operation (power is ON.) or OFFLINE operation.
Orange (blinking)	During software startup.
Red (lit)	Power is ON.
Not lit	Power is OFF.

B: USB Host Interface (USB)

USB 1.1 compliant.
 One port for the TYPE-A Connector.
 Power supply voltage: DC5V ±5%.
 Maximum output current: 500mA
 Maximum communication distance: 5m
 Interfaces to transfer cable, USB-compatible printer, and other compatible devices.

C: CF Card Access LED

This lamp light up when CF card is inserted and CF card cover is closed. However, opening the CF card cover, in the CF card while accessing it continues to light up.

Access LED	Indicates
Green ON	The CF Card is inserted and the CF Card Cover is closed. Or, the CF Card is being accessed.
Green OFF	The CF Card is not inserted or is not being accessed.

D: Power Input Terminal Block (AC type), Power Plug Connector (DC type)

E: CF Card Cover

The CF Card I/F and DIP Switches are located in the CF Card Cover opening. This cover must be closed when accessing the CF Card.

F: Serial Interface (COM1)

RS-232C serial interface. D-Sub 9-pin plug type connector.

G: Serial Interface (COM2)

RS-422/RS-485^{*1} serial interface. D-Sub 9-pin plug type connector.

*1 RS-485 is compliant with AST-3501C / AST-3501T with revision code "B" or later.

SEE → About Revision (page 12)

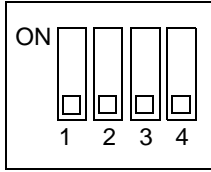
H: DIP Switches

DIP Switches	Function	ON	OFF	Note
1	Start up from CF Card	Enabled	Disabled	CF Card with startup data required
2*	Forced transfer mode	Forced Transfer Mode: ON	Forced Transfer Mode: OFF	-
3	Reserved	-	-	Constantly OFF
4	Simulate cover closed, allowing card to be read even if cover open	Enabled	Disabled	Used when CF Card cover is damaged

* When the unit turns ON with DIP switch 2 ON, the unit starts in transfer mode. Under normal operating conditions, set to OFF.

3

Specifications

1. ST-3200 Series
2. ST-3300 Series
3. ST-3400 Series
4. ST-3500 Series

This chapter describes the general specifications, functions, interfaces, and external drawings of the ST.

3.1 ST-3200 Series

3.1.1 General Specifications

■ Electrical Specifications

Power Supply	Input Voltage	DC24V
	Rated Voltage	DC19.2 to 28.8V
	Allowable Voltage Drop	2ms (max.)
	Power Consumption	13W (max.)
	In-Rush Current	60A (max.) ^{*1}
Voltage Endurance		AC1000V 20mA for 1 minute (between charging and FG terminals)
Insulation Resistance		DC500V 10MΩ (min.) (between charging and FG terminals)

*1. The FWHM (Full-width, half maximum) value is approximately 40μs. (When exceeding 30A)

■ Environmental Specifications

Physical	Surrounding Air Temperature	0 to +50°C ^{*1}
	Storage Temperature	-20 to +60°C
	Ambient Humidity	10 to 90% RH (Wet bulb temperature: 39°C max. - no condensation.)
	Storage Humidity	10 to 90% RH (Wet bulb temperature: 39°C max. - no condensation.)
	Dust	0.1mg/m ³ and below (non-conductive levels)
	Pollution Degree	For use in Pollution Degree 2 environment.
	Atmosphere	Free of corrosive gases
	Air Pressure Vibration Resistance (altitude range)	800 to 1114hPa (sea level to 2000 meters above)
Mechanical	Vibration Resistance	IEC61131-2 compliant 5 to 9Hz single-amplitude 3.5mm[0.14in] 9 to 150Hz constant-accelerated velocity 9.8m/s ² X,Y,Z directions for 10 cycle (100 minute)
	Concussion Resistance	IEC61131-2 compliant (147m/s ² X,Y,Z directions for 3 times)
Electrical	Noise Immunity	Noise Voltage: 1000V _{p-p} Pulse Duration: 1μs Rise Time: 1ns (via noise simulator)
	Electrostatic Discharge Immunity	6kV (complies with EN 61000-4-2 Level 3)

*1. Extended use in environments where surrounding air temperature is 40°C or higher may degrade the display quality and result in decreased contrast.

■ Structural Specifications

Installation	Grounding	Grounding resistance of 100Ω 2mm ² or thicker wire, or your country's applicable standard. (Same for FG and SG terminals)
	Structure* ¹	Rating: Equivalent to IP65f NEMA #250 TYPE 4X/13 (Front surface at panel embedding) Feature size: All-in-one Installation configuration: Panel embedding
	Cooling Method	Natural air circulation
	Weight Approx.	0.4kg[0.9lb] max. (unit only)
	External Dimensions	W130mm[5.12in] X H104mm[4.09in] X D40mm[1.57in]
	Panel Cut Dimensions	W118.5mm[4.67in] X H92.5mm[3.64in]* ² Panel thickness: 1.6mm[0.06in] to 5.0mm[0.20in]

*1. The front face of the ST unit, installed in a solid panel, has been tested using conditions equivalent to the standards shown in the specification. Even though the ST unit's level of resistance is equivalent to these standards, oils that should have no effect on the ST can possibly harm the unit. This can occur in areas where either vaporized oils are present, or where low viscosity cutting oils are allowed to adhere to the unit for long periods of time. If the ST's front face protection sheet becomes peeled off, these conditions can lead to the ingress of oil into the ST and separate protection measures are suggested.

Also, if non-approved oils are present, it may cause deformation or corrosion of the front panel's plastic cover. Therefore, prior to installing the ST be sure to confirm the type of conditions that will be present in the ST's operating environment.

If the installation gasket is used for a long period of time, or if the unit and its gasket are removed from the panel, the original level of the protection cannot be guaranteed. To maintain the original protection level, be sure to replace the installation gasket regularly.

*2. Dimensional tolerance: everything +1/-0mm[+0.04/-0in] and R in angle are below R3[0.12].

3.1.2 Performance Specifications

■ Performance Specifications

		AST-3201A	AST-3211A
Application*1		FLASH EPROM 6MB	
Data Backup		SRAM 320KB	
		Used lithium battery for backup memory	
Interface	Serial Interface	COM1: RS-232C Asynchronous Transmission Data Length: 7 bit/8 bit Parity: none, Odd or Even Stop Bit: 1bit/2bit Data Transmission Speed: 2400 bps to 115.2 kbps Connector: D-Sub 9pin plug	COM1: RS-232C Asynchronous Transmission Data Length: 7 bit/8 bit Parity: none, Odd or Even Stop Bit: 1bit/2bit Data Transmission Speed: 2400 bps to 115.2 kbps Connector: D-Sub 9pin plug
		COM2: RS-422/RS-485*2 Asynchronous Transmission Data Length: 7 bit/8 bit Parity: none, Odd or Even Stop Bit: 1bit/2bit Data Transmission Speed: 2400 bps to 115.2 kbps (RS-422/RS-485) 187.5 kbps (MPI) Connector: D-Sub 9pin plug	COM2: RS-485 (MPI only) Asynchronous Transmission Data Length: 7bit/8bit Parity: none, Odd or Even Stop Bit: 1bit/2bit Data Transmission Speed: 187.5 kbps (MPI) Connector: D-Sub 9pin socket
	USB Host Interface	USB 1.1 compliant. (TYPE-A conn.) x 1 Power Supply Voltage: DC5V ± 5% Output Current: 500mA (Max.) Communication Distance: 5m (Max.)	
Clock Accuracy*3		± 65 seconds/ month (at room temperature)	

*1. User active capacity.

*2. RS-485 is compliant with AST-3201A units with revision code "C" or later.

SEE → *About Revision (page 12)*

*3. The ST's internal clock has a slight error. At normal operating temperatures and conditions, with the ST operating from its lithium battery, the degree of error is 65 seconds per month. Variations in operating conditions and battery life can cause this error to vary from -380 to +90 seconds per month. For systems where this degree of error will be a problem, the user should be sure to monitor this error and make adjustments when required.

NOTE

- When the message “RAAA051 Low battery” is displayed, supply power to the display unit and fully charge the battery. The battery charges within 24 hours to a level which allows backup operation. Completing a full charge requires about 96 hours (4 days).
- A Lithium battery's lifetime is: 10 years when the battery's ambient temperature is 40°C or less. 4.1 years when the battery's ambient temperature is 50°C or less. 1.5 years when the battery's ambient temperature is 60°C or less.
 When used for backup:
 Approximately 100 days, with a fully charged battery.
 Approximately 6 days, with a half-charged battery.

■ Display Specifications

Display Type		Monochrome Amber/Red LCD
Resolution		W320 X H240 pixels
Dot pitch		W0.24mm[0.01in] X H0.24mm[0.01in]
Effective Display Area		W78.8mm[3.10in] X H59.6mm[2.35in]
Color/Shade level		Black and White (8 Shades)
Backlight		LED (Not replaceable)
Brightness control		16 levels of adjustment available via touch panel
Contrast Adjustment		8 levels of adjustment available via touch panel
Backlight Service Life		50000hrs. or more (at 25°C and continuous operation - period until backlight brightness decreases to 50%.)
Language Fonts		Japanese: 6962 (JIS Standards 1 & 2) (including 607 non-kanji characters) ANK: 158 (Korean fonts, Simplified Chinese and Taiwanese traditional Chinese fonts are downloadable.)
Text composition	Character Sizes	Standard font: 8X8, 8X16, 16X16 and 32X32 dot fonts Stroke font: 6 to 127 dot fonts
	Font Sizes	Standard font: Width can be expanded up to 8 times. Height can be expanded up to 8 times ^{*1}
Text	8 X 8 dots	40 Char. X 30 rows
	8 X 16 dots	40 Char. X 15 rows
	16 X 16 dots	20 Char. X 15 rows
	32 X 32 dots	10 Char. X 7 rows

*1. Font Sizes can be set up by software.

■ Touch Panel Specifications

Type	Resistive Film (analog)
Resolution	1024 X 1024
Service Life	1000000 times or more

3.1.3 Interface Specifications

This section describes the specifications of each interface of the ST Series unit.

IMPORTANT

- The serial interface of the ST Series (except AST-3211A COM2) does not have an isolation function. When the host (PLC) unit is also not isolated, be sure to connect Pin #5 SG (Signal Ground) terminal to reduce the risk of damaging the RS-232C/RS-422/RS-485 circuit.
- ST Series (except AST-3211A COM2) have the SG (signal ground) connection and the FG (frame ground) connection inside. When connecting an external device to the ST using the SG terminal, be sure to check that no short-circuit loop is created when you setup the system.
- The same type of connector is used for COM1 and COM2 of the AST-3201A. Be careful not to mistake one for the other. Connecting them incorrectly disables communication.

NOTE

- Connecting the RS-232C isolation unit (CA3-ISO232-01) to COM1 enables isolation if needed.

■ AST-3201A

◆ Serial Interfaces (COM1)

This interface is used to connect an RS-232C cable. D-Sub 9-pin plug connector is used.

<ST unit side>

ST Connector	XM2C-0942-502LX <OMRON Co.>
Interfit Bracket	#4-40 inch screws are used.

<Cable side>

Recommended Cable Connector	XM2D-0901 <OMRON Co.>
Recommended Cable Cover	XM2S-0913 <OMRON Co.>
Recommended Jack Screw	XM2Z-0073 <OMRON Co.>

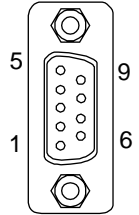
Pin Arrangement	Pin No.	RS-232C		
		Signal Name	Direction	Meaning
 <p>(ST unit side)</p>	1	CD	Input	Carrier Detect
	2	RD(RXD)	Input	Receive Data
	3	SD(TXD)	Output	Send Data
	4	ER(DTR)	Output	Data Terminal Ready
	5	SG	-	Signal Ground
	6	DR(DSR)	Input	Data Set Ready
	7	RS(RTS)	Output	Request to Send
	8	CS(CTS)	Input	Send Possible
	9	CI(RI)/VCC	Input/-	Called status display +5V±5% Output 0.25A *1
	Shell	FG	-	Frame Ground (Common with SG)

*1. The RI/VCC selection for Pin #9 is switched via software. The VCC output is not protected against overcurrent. To prevent damage or a unit malfunction, use only the rated current.

◆ Serial Interface (COM2)

This interface is used to connect an RS-422/RS-485*1 serial cable. A D-Sub 9-pin plug connector is used.

<ST unit side>

ST Connector	XM2C-0942-502LX <OMRON Co.>
Interfit Bracket	#4-40 inch screws are used.

<Cable side>

Recommended Cable Connector	XM2D-0901 <OMRON Co.>
Recommended Cable Cover	XM2S-0913 <OMRON Co.>
Recommended Jack Screw	XM2Z-0073 <OMRON Co.>

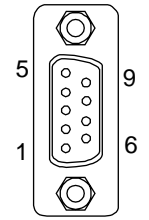
Pin Arrangement	Pin No.	RS-422/RS-485*1		
		Signal Name	Direction	Meaning
 <p>(ST unit side)</p>	1	RDA	Input	Receive Data A(+)
	2	RDB	Input	Receive Data B(-)
	3	SDA	Output	Send Data A(+)
	4	ERA	Output	Data Terminal Ready A(+)
	5	SG	-	Signal Ground
	6	CSB	Input	Send Possible B(-)
	7	SDB	Output	Send Data B(-)
	8	CSA	Input	Send Possible A(+)
	9	ERB	Output	Data Terminal Ready B(-)
	Shell	FG	-	Frame Ground (Common with SG)

*1 RS-485 is compliant with AST-3201A units with revision code "C" or later.

SEE → About Revision (page 12)

■ AST-3211A

◆ Serial Interface (COM1)

This interface is used to connect an RS-232C serial cable. A D-Sub 9-pin plug connector is used.

<ST unit side>

ST Connector	XM2C-0942-502LX <OMRON Co.>
Interfit Bracket	#4-40 inch screws are used.

<Cable side>

Recommended Cable Connector	XM2D-0901 <OMRON Co.>
Recommended Cable Cover	XM2S-0913 <OMRON Co.>
Recommended Jack Screw	XM2Z-0073 <OMRON Co.>

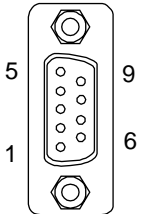
Pin Arrangement	Pin No.	RS-232C		
		Signal Name	Direction	Meaning
 <p>(ST unit side)</p>	1	CD	Input	Carrier Detect
	2	RD(RXD)	Input	Receive Data
	3	SD(TXD)	Output	Send Data
	4	ER(DTR)	Output	Data Terminal Ready
	5	SG	-	Signal Ground
	6	DR(DSR)	Input	Data Set Ready
	7	RS(RTS)	Output	Request to Send
	8	CS(CTS)	Input	Send Possible
	9	CI(RI)/VCC	Input/-	Called status display +5V±5% Output 0.25A *1
	Shell	FG	-	Frame Ground (Common with SG)

*1. The RI/VCC selection for Pin #9 is switched via software. The VCC output is not protected against overcurrent. To prevent damage or a unit malfunction, use only the rated current.

◆ Serial Interface (COM2)

This interface is used to connect an RS-485 (MPI only) serial cable. A D-Sub 9-pin socket connector is used.

<ST unit side>

ST Connector	XM3B-0942-502LX <OMRON Co.>
Interfit Bracket	#4-40 inch screws are used.

<Cable side>

Recommended Cable Connector	XM2A-0901 <OMRON Co.>
Recommended Cable Cover	XM2S-0913 <OMRON Co.>
Recommended Jack Screw	XM2Z-0073 <OMRON Co.>

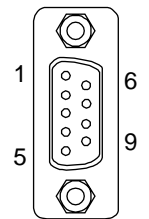
Pin Arrangement	Pin No.	RS-485 (MPI only)		
		Signal Name	Direction	Meaning
 <p>(ST unit side)</p>	1	NC	-	-
	2	NC	-	-
	3	LINE(+)	Input/ Output	LINE(+)
	4	RS(RTS)	Output	Request to Send
	5	SG	-	Signal Ground ^{*1}
	6	5V	-	5V External Output ^{*2 *3}
	7	NC	-	-
	8	LINE(-)	Input/ Output	LINE(-)
	9	NC	-	-
	Shell	FG	-	Frame Ground ^{*1} (Common with SG)

*1. The SG and FG terminals are isolated.

*2. The 5V output for Pin # 6 is not protected against overcurrent. To prevent damage or unit malfunctions, use only the rated current.

*3. When providing power via the Siemens Co.'s PROFIBUS connector, power cannot be connected to the Device/PLC.

3.1.4 Dimensions

The following dimensions apply to ST-3200 Series units.

■ Installation Fasteners Attached Dimensions

Unit: mm[in.]

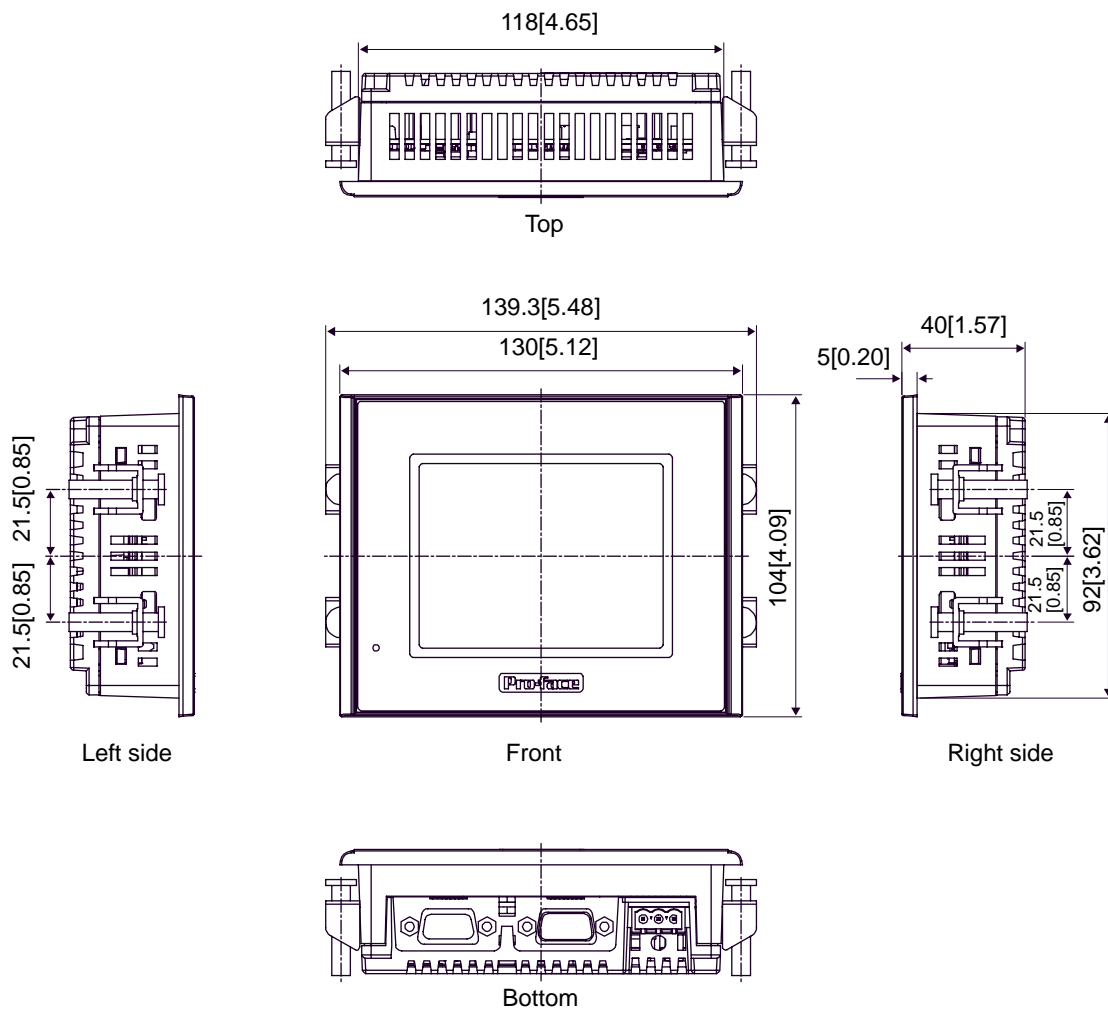

■ Cable Attached Dimensions

Unit: mm[in.]

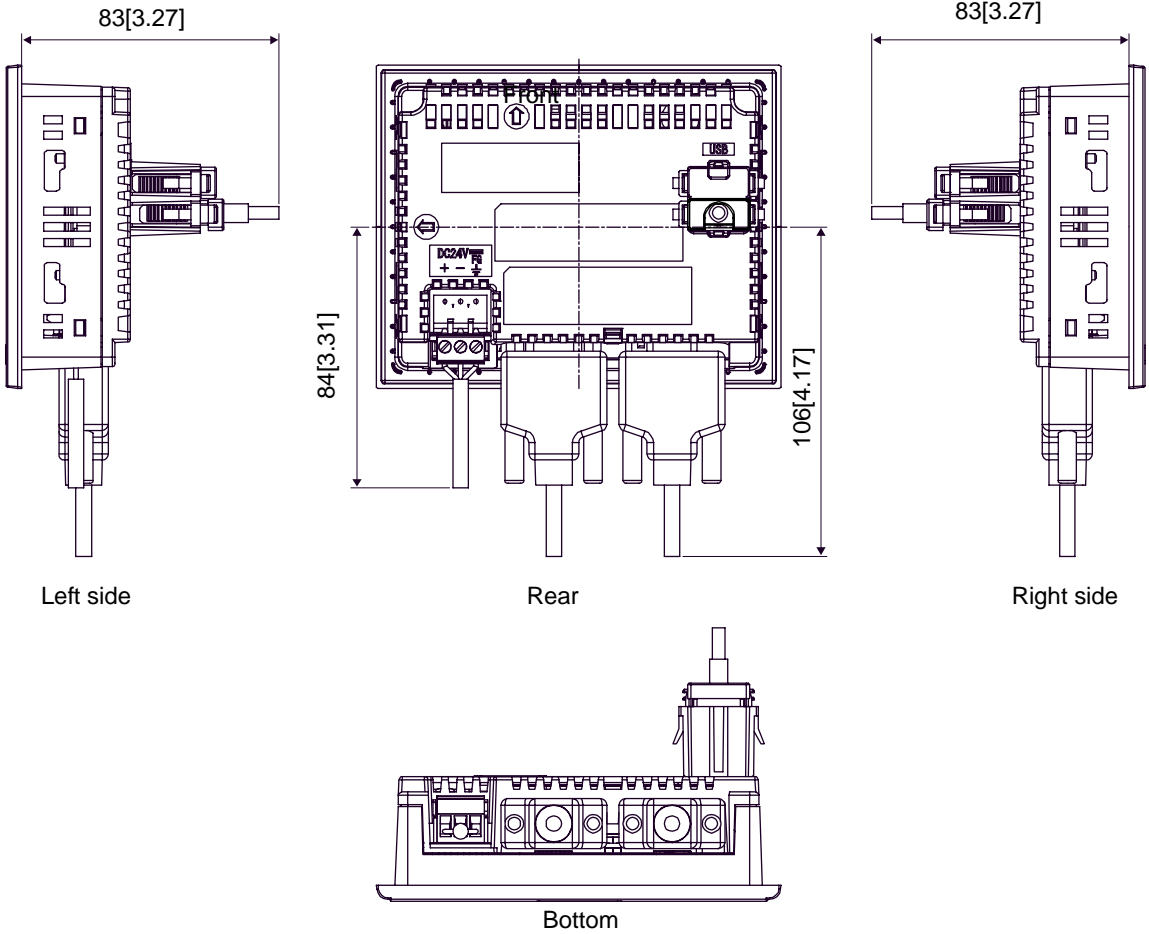

IMPORTANT

- All the above values are designed in case of cable bending. The dimensions given here are representative values depending on the type of connection cable used. Therefore, they are all intended for reference only.

■ Panel Cut Dimensions

Unit: mm[in.]

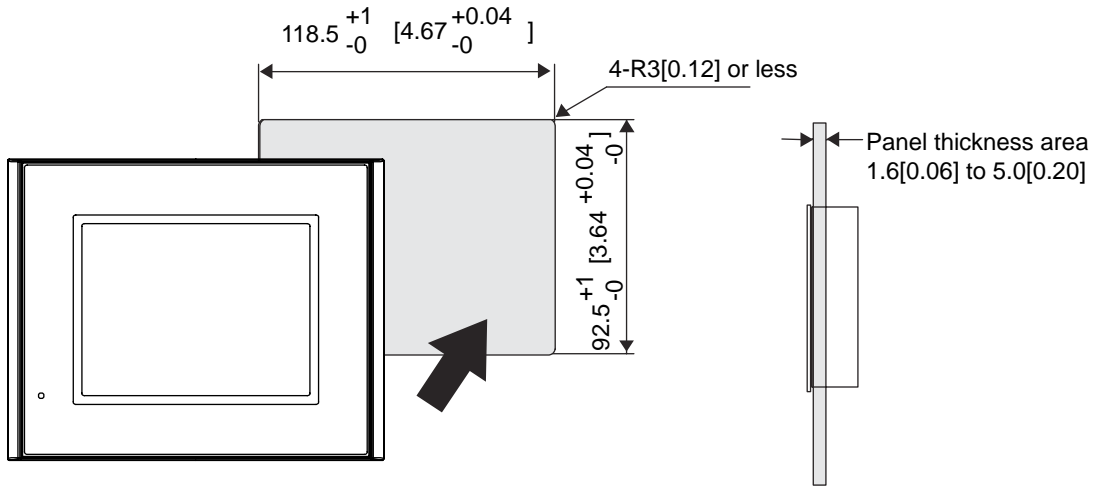

■ Installation Fasteners

Unit: mm[in.]

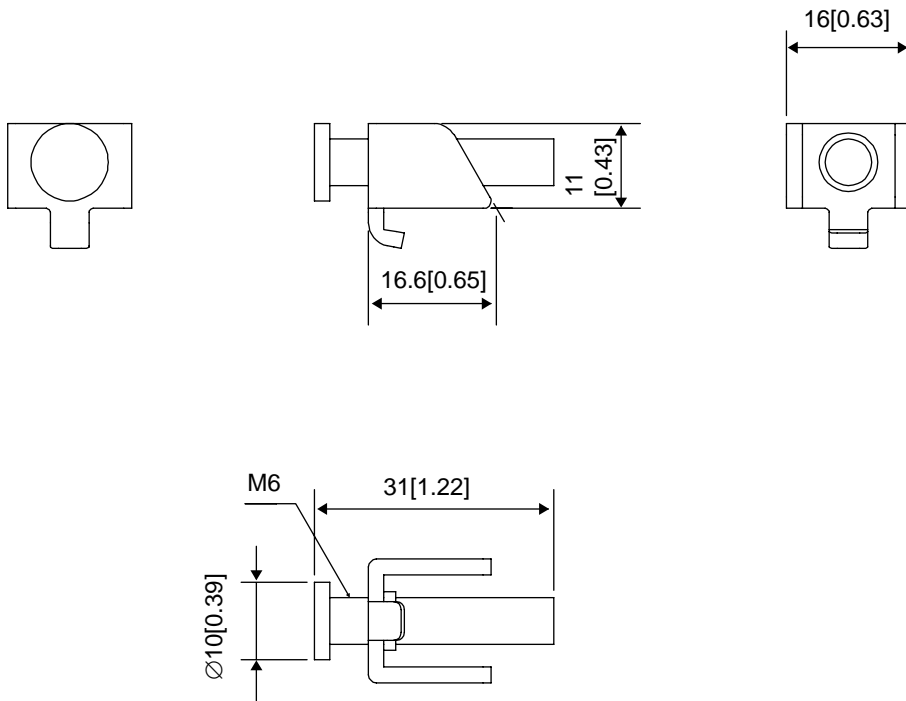

3.2 ST-3300 Series

3.2.1 General Specifications

■ Electrical Specifications

Power Supply	Input Voltage	DC24V
	Rated Voltage	DC19.2 to 28.8V
	Allowable Voltage Drop	10ms (max.)
	Power Consumption	18W (max.)
	In-Rush Current	30A (max.)
Voltage Endurance	AC1000V 20mA for 1 minute (between charging and FG terminals)	
Insulation Resistance	DC500V 10M Ω (min.) (between charging and FG terminals)	

■ Environmental Specifications

Physical	Surrounding Air Temperature	0 to +50°C*1
	Storage Temperature	-20 to +60°C
	Ambient Humidity	10 to 90% RH (Wet bulb temperature: 39°C max. - no condensation.)
	Storage Humidity	10 to 90% RH (Wet bulb temperature: 39°C max. - no condensation.)
	Dust	0.1mg/m ³ and below (non-conductive levels)
	Pollution Degree	For use in Pollution Degree 2 environment
	Atmosphere	Free of corrosive gases
	Air Pressure Vibration Resistance (altitude range)	800 to 1114hPa (sea level to 2000 meters above)
Mechanical	Vibration Resistance	IEC61131-2 compliant 5 to 9Hz single-amplitude 3.5mm[0.14in] 9 to 150Hz constant-accelerated velocity 9.8m/s ² X,Y,Z directions for 10 cycle (100 minute)
	Concussion Resistance	IEC61131-2 compliant (147m/s ² X,Y,Z directions for 3 times)
Electrical	Noise Immunity	Noise Voltage: 1000V _{P-P} Pulse Duration: 1 μ s Rise Time: 1ns (via noise simulator)
	Electrostatic Discharge Immunity	6kV (complies with EN 61000-4-2 Level 3)

*1. When using Monochrome / STN Color LCD model in an environment where the temperature reaches or exceeds 40°C for an extended period of time, the screen contrast level may decrease from its original level of brightness.

■ Structural Specifications

Installation	Grounding	Grounding resistance of 100Ω 2mm ² or thicker wire, or your country's applicable standard. (Same for FG and SG terminals)
	Structure *1	Rating: Equivalent to IP65f NEMA #250 TYPE 4X/13 (Front surface at panel embedding) Feature size: All-in-one Installation configuration: Panel embedding
	Cooling Method	Natural air circulation
	Weight Approx.	1.0kg[2.2lb]max. (unit only)
	External Dimensions	W167.5mm[6.59in] X H135mm[5.31in] X D59.5mm[2.34in]
	Panel Cut Dimensions	W156.0mm[6.14in] X H123.5mm[4.86in]* ² Panel thickness: 1.6mm[0.06in] to 5.0mm[0.20in]

- *1. The front face of the ST unit, installed in a solid panel, has been tested using conditions equivalent to the standards shown in the specification. Even though the ST unit's level of resistance is equivalent to these standards, oils that should have no effect on the ST can possibly harm the unit. This can occur in areas where either vaporized oils are present, or where low viscosity cutting oils are allowed to adhere to the unit for long periods of time. If the ST's front face protection sheet becomes peeled off, these conditions can lead to the ingress of oil into the ST and separate protection measures are suggested.
- Also, if non-approved oils are present, it may cause deformation or corrosion of the front panel's plastic cover. Therefore, prior to installing the ST be sure to confirm the type of conditions that will be present in the ST's operating environment.
- If the installation gasket is used for a long period of time, or if the unit and its gasket are removed from the panel, the original level of the protection cannot be guaranteed. To maintain the original protection level, be sure to replace the installation gasket regularly.
- *2. Dimensional tolerance: everything +1/-0mm[+0.04/-0in] and R in angle are below R3[0.12].

3.2.2 Performance Specifications

■ Performance Specifications

		AST-3301B, AST-3301S, AST-3301T	AST-3302B
Application ^{*1}	FLASH EPROM 6MB		
Data Backup	SRAM 320KB		
	Used lithium battery for backup memory		
Interface	Serial Interface	COM1: RS-232C Asynchronous Transmission: Data Length: 7 bit/8 bit Parity: none, Odd or Even Stop Bit: 1bit/2bit Data Transmission Speed: 2400bps to 115.2 kbps Connector: D-Sub 9pin plug	
		COM2: RS-422/RS-485 ^{*2} Asynchronous Transmission Data Length: 7 bit/8 bit Parity: none, Odd or Even Stop Bit: 1bit/2bit Data Transmission Speed: 2400 bps to 115.2 kbps (RS-422/RS-485) 187.5 kbps (MPI) Connector: D-Sub 9pin plug	COM2: RS-485(MPI only) Asynchronous Transmission Data Length: 7bit/8bit Parity: none, Odd or Even Stop Bit: 1bit/2bit Data Transmission Speed: 187.5 kbps (MPI) Connector: D-Sub 9pin socket
	USB Host Interface	USB 1.1 compliant. (TYPE-A conn.) x 1 Power Supply Voltage: DC5V ± 5% Output Current: 500mA (Max.) Communication Distance: 5m (Max.)	
Clock Accuracy ^{*3}	±65 seconds/ month (at room temperature)		

*1. User active capacity.

*2. RS-485 is compliant with AST-3301B / AST-3301S with revision code "B" or later. For all other models, all revisions support RS-485.

SEE → *About Revision (page 12)*

*3. The ST's internal clock has a slight error. At normal operating temperatures and conditions, with the ST operating from its lithium battery, the degree of error is 65 seconds per month. Variations in operating conditions and battery life can cause this error to vary from -380 to +90 seconds per month. For systems where this degree of error will be a problem, the user should be sure to monitor this error and make adjustments when required.

NOTE

- When the message “RAAA051 Low battery” is displayed, supply power to the display unit and fully charge the battery. The battery charges within 24 hours to a level which allows backup operation. Completing a full charge requires about 96 hours (4 days).
- A Lithium battery’s lifetime is: 10 years when the battery’s ambient temperature is 40°C or less. 4.1 years when the battery’s ambient temperature is 50°C or less. 1.5 years when the battery’s ambient temperature is 60°C or less.

When used for backup:

Approximately 100 days, with a fully charged battery.

Approximately 6 days, with a half-charged battery.

■ Display Specifications

	AST-3301B	AST-3302B	AST-3301S	AST-3301T
Display Type	Monochrome blue mode LCD		STN Color LCD	TFT Color LCD
Resolution	W320 X H240 pixels			
Dot pitch	W0.36mm[0.01in] X H0.36mm[0.01in]			
Effective Display Area	W115.2mm[4.54in] X H86.4mm[3.40in]			
Color/Shade level	8 Shades		256 Colors (No blink) 64 Colors (Enables blink feature)	
Backlight	CCFL (Not replaceable)			
Brightness control	8 levels of adjustment available via touch panel			
Contrast Adjustment	8 levels of adjustment available via touch panel			Not Applicable
Backlight Service Life	58000hrs. or more (at 25°C and continuous operation - period until backlight brightness decreases to 50% or backlight starts to flicker)		75000hrs. or more (at 25°C and con- tinuous operation - period until backlight bright- ness decreases to 50% or backlight starts to flicker)	50000hrs. or more (at 25°C and con- tinuous operation - period until backlight bright- ness decreases to 50% or backlight starts to flicker)
Language Fonts	Japanese: 6962 (JIS Standards 1 & 2) (including 607 non-kanji characters) ANK: 158 (Korean fonts, Simplified Chinese and Taiwanese traditional Chinese fonts are downloadable.)			
Text composition	Character Sizes	Standard font: 8X8, 8X16, 16X16 and 32X32 dot fonts Stroke font: 6 to 127 dot fonts		
	Font Sizes	Standard font: Width can be expanded up to 8 times. Height can be expanded up to 8 times ^{*1}		
Text	8 X 8 dots	40 Char. X 30 rows		
	8 X 16 dots	40 Char. X 15 rows		
	16 X 16 dots	20 Char. X 15 rows		
	32 X 32 dots	10 Char. X 7 rows		

*1. Font Sizes can be set up by software.

■ Touch Panel Specifications

Type	Resistive Film (analog)
Resolution	1024 X 1024
Service Life	1000000 times or more

3.2.3 Interface Specifications

This section describes the specifications of each interface of the ST Series unit.

IMPORTANT

- The serial interface of the ST Series (except AST-3302B COM2) does not have an isolation function. When the host (PLC) unit is also not isolated, be sure to connect Pin #5 SG (Signal Ground) terminal to reduce the risk of damaging the RS-232C/RS-422/RS-485 circuit.
- ST Series (except AST-3302B COM2) have the SG (signal ground) connection and the FG (frame ground) connection inside. When connecting an external device to the ST using the SG terminal, be sure to check that no short-circuit loop is created when you setup the system.
- The same type of connector is used for COM1 and COM2 of the ST (except AST-3302B). Be careful not to mistake one for the other. Connecting them incorrectly disables communication.

NOTE

- Connecting the RS-232C isolation unit (CA3-ISO232-01) to COM1 enables isolation if needed.

■ AST-3301B, AST-3301S, AST-3301T

◆ Serial Interface (COM1)

This interface is used to connect an RS-232C serial cable. A D-Sub 9-pin plug connector is used.

<ST unit side>

ST Connector	XM2C-0942-502LX <OMRON Co.>
Interfit Bracket	#4-40 inch screws are used.

<Cable side>

Recommended Cable Connector	XM2D-0901 <OMRON Co.>
Recommended Cable Cover	XM2S-0913 <OMRON Co.>
Recommended Jack Screw	XM2Z-0073 <OMRON Co.>

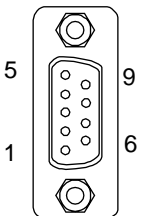
Pin Arrangement	Pin No.	RS-232C		
		Signal Name	Direction	Meaning
 <p>(ST unit side)</p>	1	CD	Input	Carrier Detect
	2	RD(RXD)	Input	Receive Data
	3	SD(TXD)	Output	Send Data
	4	ER(DTR)	Output	Data Terminal Ready
	5	SG	-	Signal Ground
	6	DR(DSR)	Input	Data Set Ready
	7	RS(RTS)	Output	Request to Send
	8	CS(CTS)	Input	Send Possible
	9	CI(RI)/VCC	Input/-	Called status display +5V±5% Output 0.25A *1
	Shell	FG	-	Frame Ground (Common with SG)

*1 The RI/VCC selection for Pin #9 is switched via software. The VCC output is not protected against overcurrent. To prevent damage or a unit malfunction, use only the rated current.

◆ Serial Interface (COM2)

This interface is used to connect an RS-422/RS-485*¹ serial cable. A D-Sub 9-pin plug connector is used.

<ST unit side>

ST Connector	XM2C-0942-502LX <OMRON Co.>
Interfit Bracket	#4-40 inch screws are used.

<Cable side>

Recommended Cable Connector	XM2D-0901 <OMRON Co.>
Recommended Cable Cover	XM2S-0913 <OMRON Co.>
Recommended Jack Screw	XM2Z-0073 <OMRON Co.>

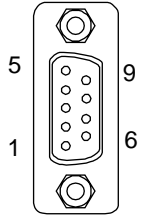
Pin Arrangement	Pin No.	RS-422/RS-485* ¹		
		Signal Name	Direction	Meaning
 <p>(ST unit side)</p>	1	RDA	Input	Receive Data A(+)
	2	RDB	Input	Receive Data B(-)
	3	SDA	Output	Send Data A(+)
	4	ERA	Output	Data Terminal Ready A(+)
	5	SG	-	Signal Ground
	6	CSB	Input	Send Possible B(-)
	7	SDB	Output	Send Data B(-)
	8	CSA	Input	Send Possible A(+)
	9	ERB	Output	Data Terminal Ready B(-)
	Shell	FG	-	Frame Ground (Common with SG)

*1 RS-485 is compliant with AST-3301B / AST-3301S with revision code "B" or later. For all other models, all revisions support RS-485.

SEE → About Revision (page 12)

■ AST-3302B

◆ Serial Interface (COM1)

This interface is used to connect an RS-232C serial cable. A D-Sub 9-pin plug connector is used.

<ST unit side>

ST Connector	XM2C-0942-502LX <OMRON Co.>
Interfit Bracket	#4-40 inch screws are used.

<Cable side>

Recommended Cable Connector	XM2D-0901 <OMRON Co.>
Recommended Cable Cover	XM2S-0913 <OMRON Co.>
Recommended Jack Screw	XM2Z-0073 <OMRON Co.>

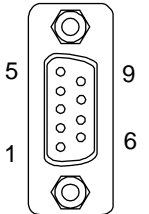
Pin Arrangement	Pin No.	RS-232C		
		Signal Name	Direction	Meaning
 <p>(ST unit side)</p>	1	CD	Input	Carrier Detect
	2	RD(RXD)	Input	Receive Data
	3	SD(TXD)	Output	Send Data
	4	ER(DTR)	Output	Data Terminal Ready
	5	SG	-	Signal Ground
	6	DR(DSR)	Input	Data Set Ready
	7	RS(RTS)	Output	Request to Send
	8	CS(CTS)	Input	Send Possible
	9	CI(RI)/VCC	Input/-	Called status display +5V±5% Output 0.25A *1
	Shell	FG	-	Frame Ground (Common with SG)

*1. The RI/VCC selection for Pin #9 is switched via software. The VCC output is not protected against overcurrent. To prevent damage or a unit malfunction, use only the rated current.

◆ Serial Interface (COM2)

This interface is used to connect an RS-485 (MPI only) serial cable. A D-Sub 9-pin socket connector is used.

<ST unit side>

ST Connector	XM3B-0942-502LX <OMRON Co.>
Interfit Bracket	#4-40 inch screws are used.

<Cable side>

Recommended Cable Connector	XM2A-0901 <OMRON Co.>
Recommended Cable Cover	XM2S-0913 <OMRON Co.>
Recommended Jack Screw	XM2Z-0073 <OMRON Co.>

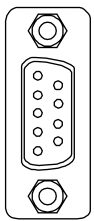
Pin Arrangement	Pin No.	RS-485 (MPI only)		
		Signal Name	Direction	Meaning
 <p>(ST unit side)</p>	1	NC	-	-
	2	NC	-	-
	3	LINE(+)	Input/ Output	LINE(+)
	4	RS(RTS)	Output	Request to Send
	5	SG	-	Signal Ground ^{*1}
	6	5V	-	5V External Output ^{*2 *3}
	7	NC	-	-
	8	LINE(-)	Input/ Output	LINE(-)
	9	NC	-	-
	Shell	FG	-	Frame Ground ^{*1} (Common with SG)

*1. The SG and FG terminals are isolated.

*2. The 5V output for Pin # 6 is not protected against overcurrent. To prevent damage or unit malfunctions, use only the rated current.

*3. When providing power via the Siemens Co.'s PROFIBUS connector, power cannot be connected to the Device/PLC.

3.2.4 Dimensions

The following dimensions apply to all ST-3300 Series units.

■ Installation Fasteners Attached Dimensions

Unit: mm[in.]

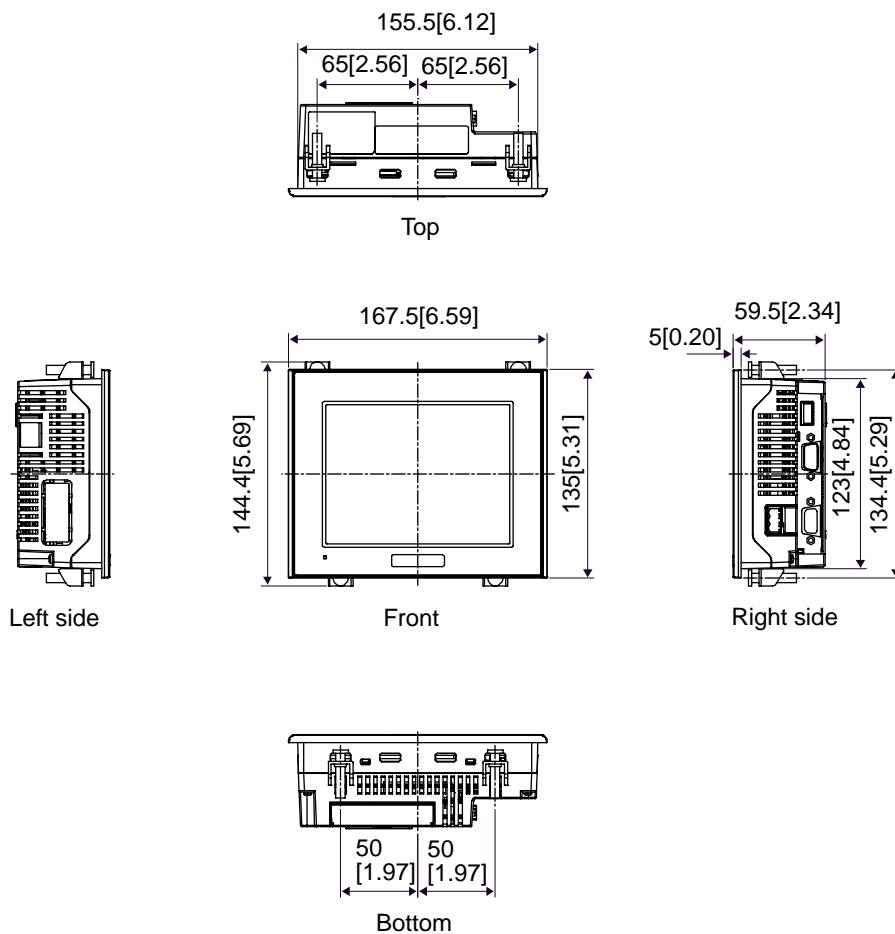

■ Cable Attached Dimensions

Unit:mm[in.]

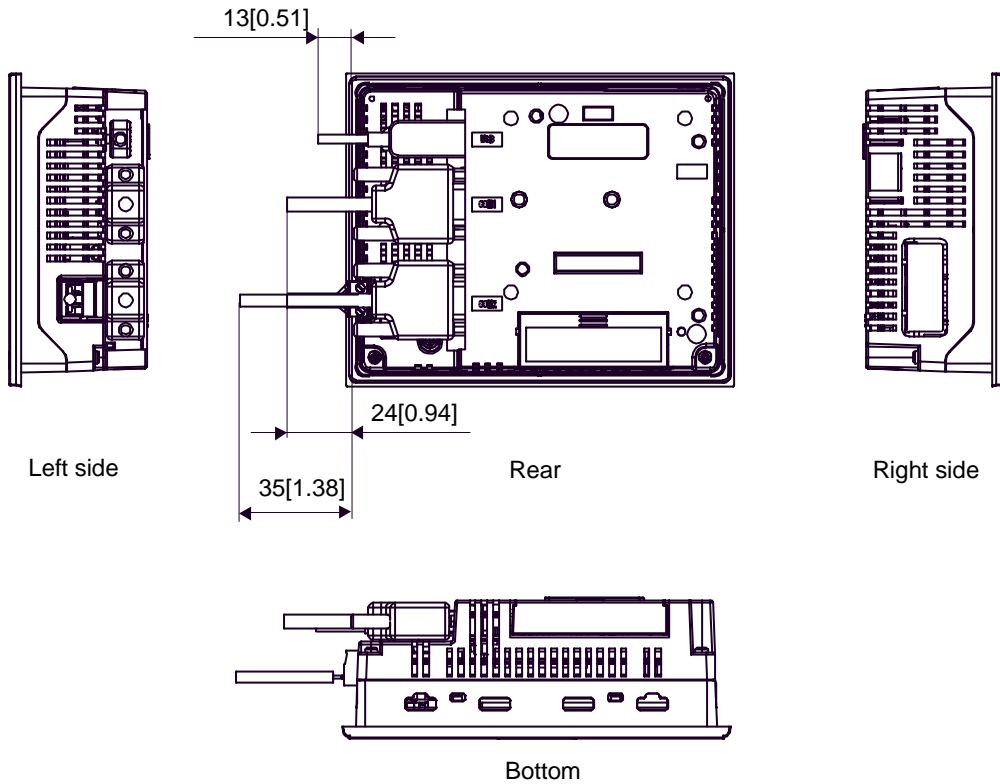

IMPORTANT

- All the above values are designed in case of cable bending. The dimensions given here are representative values depending on the type of connection cable used. Therefore, they are all intended for reference only.

■ Panel Cut Dimensions

Unit: mm[in.]

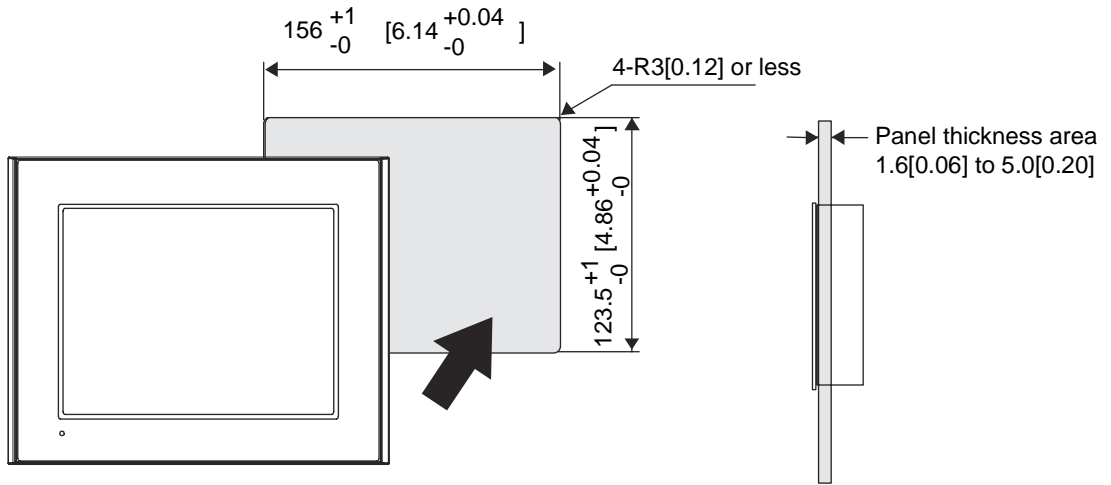

■ Installation Fasteners

Unit: mm[in.]

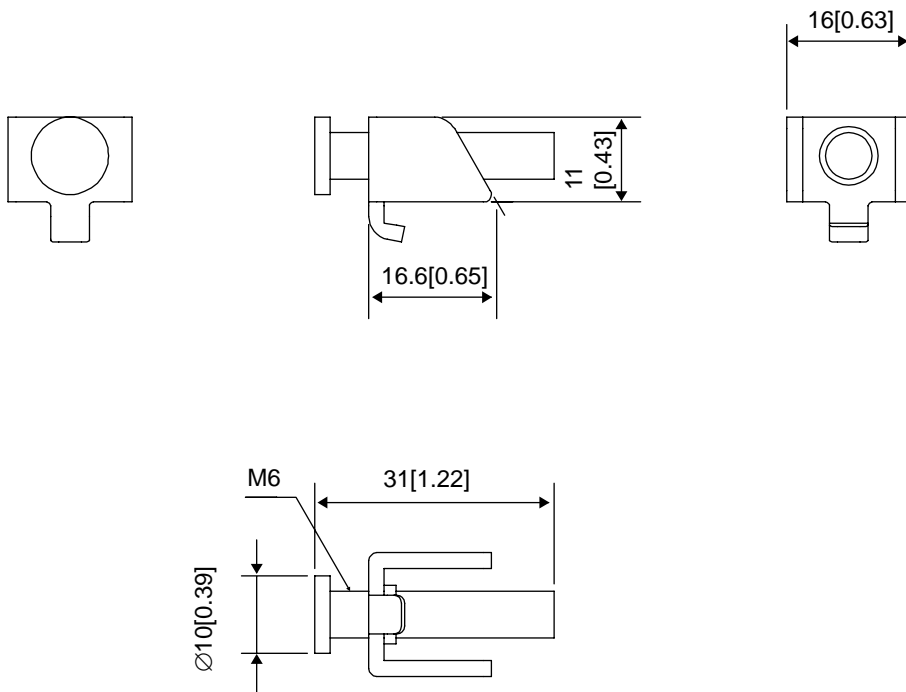

3.3 ST-3400 Series

3.3.1 General Specifications

■ Electrical Specifications

Power Supply	Input Voltage	DC24V
	Rated Voltage	DC19.2 to 28.8V
	Allowable Voltage Drop	10ms (max.)
	Power Consumption	22W (max.)
	In-Rush Current	30A (max.)
Voltage Endurance	AC1000V 20mA for 1 minute (between charging and FG terminals)	
Insulation Resistance	DC500V 10M Ω (min.) (between charging and FG terminals)	

■ Environmental Specifications

Physical	Surrounding Air Temperature	0 to +50°C
	Storage Temperature	-20 to +60°C
	Ambient Humidity	10 to 90% RH (Wet bulb temperature: 39°C max. - no condensation.)
	Storage Humidity	10 to 90% RH (Wet bulb temperature: 39°C max. - no condensation.)
	Dust	0.1mg/m ³ and below (non-conductive levels)
	Pollution Degree	For use in Pollution Degree 2 environment
	Atmosphere	Free of corrosive gases
	Air Pressure Vibration Resistance (altitude range)	800 to 1114hPa (sea level to 2000 meters above)
Mechanical	Vibration Resistance	IEC61131-2 compliant 5 to 9Hz single-amplitude 3.5mm[0.14in] 9 to 150Hz constant-accelerated velocity 9.8m/s ² X,Y,Z directions for 10 cycle (100 minute)
	Concussion Resistance	IEC61131-2 compliant (147m/s ² X,Y,Z directions for 3 times)
Electrical	Noise Immunity	Noise Voltage: 1000V _{P-P} Pulse Duration: 1 μ s Rise Time: 1ns (via noise simulator)
	Electrostatic Discharge Immunity	6kV (complies with EN 61000-4-2 Level 3)

■ Structural Specifications

Installation	Grounding	Grounding resistance of 100Ω 2mm ² or thicker wire, or your country's applicable standard. (Same for FG and SG terminals)
	Structure *1	Rating: Equivalent to IP65f NEMA #250 TYPE 4X/13 (Front surface at panel embedding) Feature size: All-in-one Installation configuration: Panel embedding
	Cooling Method	Natural air circulation
	Weight Approx.	1.8kg[4lb]max. (unit only)
	External Dimensions	W215mm[8.46in] X H170mm[6.69in] X D60mm[2.36in]
	Panel Cut Dimensions	W204.5mm[8.05in] X H159.5mm[6.28in]* ² Panel thickness: 1.6mm[0.06in] to 10.0mm[0.39in]

- *1. The front face of the ST unit, installed in a solid panel, has been tested using conditions equivalent to the standards shown in the specification. Even though the ST unit's level of resistance is equivalent to these standards, oils that should have no effect on the ST can possibly harm the unit. This can occur in areas where either vaporized oils are present, or where low viscosity cutting oils are allowed to adhere to the unit for long periods of time. If the ST's front face protection sheet becomes peeled off, these conditions can lead to the ingress of oil into the ST and separate protection measures are suggested.
- Also, if non-approved oils are present, it may cause deformation or corrosion of the front panel's plastic cover. Therefore, prior to installing the ST be sure to confirm the type of conditions that will be present in the ST's operating environment.
- If the installation gasket is used for a long period of time, or if the unit and its gasket are removed from the panel, the original level of the protection cannot be guaranteed. To maintain the original protection level, be sure to replace the installation gasket regularly.
- *2. Dimensional tolerance: everything +1/-0mm[+0.04/-0in] and R in angle are below R3[0.12].

3.3.2 Performance Specifications

■ Performance Specifications

Application*1		FLASH EPROM 6MB
Data Backup		SRAM 320KB
		Used lithium battery for backup memory
Interface	Serial Interface	COM1: RS-232C Asynchronous Transmission: Data Length: 7 bit/8 bit Parity: none, Odd or Even Stop Bit: 1bit/2bit Data Transmission Speed: 2400bps to 115.2 kbps Connector: D-Sub 9pin plug
		COM2: RS-422/RS-485*2 Asynchronous Transmission Data Length: 7 bit/8 bit Parity: none, Odd or Even Stop Bit: 1bit/2bit Data Transmission Speed: 2400bps to 115.2 kbps (RS-422/RS-485) 187.5 kbps (MPI) Connector: D-Sub 9pin plug
	USB Host Interface	Conforms to USB1.1. (TYPE-A conn.) x 1 Power Supply Voltage: DC5V ± 5% Output Current: 500mA (Max.) Communication Distance: 5m (Max.)
	CF Card Interface	Compact Flash CF Card Slot (TYPE-II)
Clock Accuracy*3		±65 seconds/ month (at room temperature)

*1. User active capacity.

*2. RS-485 is compliant with ST-3400 series units with revision code "A" or later.

SEE → *About Revision (page 12)*

*3. The ST's internal clock has a slight error. At normal operating temperatures and conditions, with the ST operating from its lithium battery, the degree of error is 65 seconds per month. Variations in operating conditions and battery life can cause this error to vary from -380 to +90 seconds per month. For systems where this degree of error will be a problem, the user should be sure to monitor this error and make adjustments when required.

NOTE

- When the message “RAAA051 Low battery” is displayed, supply power to the display unit and fully charge the battery. The battery charges within 24 hours to a level which allows backup operation. Completing a full charge requires about 96 hours (4 days).
- A Lithium battery’s lifetime is: 10 years when the battery’s ambient temperature is 40°C or less. 4.1 years when the battery’s ambient temperature is 50°C or less. 1.5 years when the battery’s ambient temperature is 60°C or less.

When used for backup:

Approximately 100 days, with a fully charged battery.

Approximately 6 days, with a half-charged battery.

■ Display Specifications

Display Type		TFT Color LCD
Resolution		W640 X H480 pixels
Dot pitch		W0.237[0.01in]mm X H0.237mm[0.01in]
Effective Display Area		W151.68[5.97in]mm X H113.76mm[4.48in]
Color/Shade level		256 Colors (No blink) 64 Colors (Enables blink feature)
Backlight		CCFL (Not replaceable)
Brightness control		8 levels of adjustment available via touch panel
Contrast Adjustment		Not applicable
Backlight Service Life		50000hrs. or more (at 25°C and continuous operation - period until backlight brightness decreases to 50% or backlight starts to flicker)
Language Fonts		Japanese: 6962 (JIS Standards 1 & 2) (including 607 non-kanji characters) ANK: 158 (Korean fonts, Simplified Chinese and Taiwanese traditional Chinese fonts are downloadable.
Text composition	Character Sizes	Standard font: 8X8, 8X16, 16X16 and 32X32 dot fonts Stroke font: 6 to 127 dot fonts
	Font Sizes	Standard font: Width can be expanded up to 8 times. Height can be expanded up to 8 times ^{*1}
Text	8 X 8 dots	80 Char. X 60 rows
	8 X 16 dots	80 Char. X 30 rows
	16 X 16 dots	40 Char. X 30 rows
	32 X 32 dots	20 Char. X 15 rows

*1. Font Sizes can be set up by software.

■ Touch Panel Specifications

Type	Resistive Film (analog)
Resolution	1024 X 1024
Service Life	1000000 times or more

3.3.3 Interface Specifications

This section describes the specifications of each interface of the ST Series unit.

IMPORTANT

- The ST unit's serial port is not isolated. When the host (PLC) unit is also not isolated, be sure to connect Pin #5 SG (Signal Ground) terminal to reduce the risk of damaging the RS-232C/RS-422/RS-485 circuit.
- When connecting an external device to the ST using the SG terminal, be sure to check that no short-circuit loop is created when you setup the system.
- The same type of connector is used for COM1 and COM2 of the ST. Be careful not to mistake one for the other. Connecting them incorrectly disables communication.

NOTE

- Connecting the RS-232C isolation unit (CA3-ISO232-01) to COM1 enables isolation if needed.

Serial Interfaces

◆ Serial Interface (COM1)

This interface is used to connect an RS-232C serial cable. A D-Sub 9-pin plug connector is used.

<ST unit side>

ST Connector	XM2C-0942-502LX <OMRON Co.>
Interfit Bracket	#4-40 inch screws are used.

<Cable side>

Recommended Cable Connector	XM2D-0901 <OMRON Co.>
Recommended Cable Cover	XM2S-0913 <OMRON Co.>
Recommended Jack Screw	XM2Z-0073 <OMRON Co.>

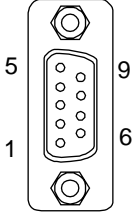
Pin Arrangement	Pin No.	RS-232C		
		Signal Name	Direction	Meaning
 <p>(ST unit side)</p>	1	CD	Input	Carrier Detect
	2	RD(RXD)	Input	Receive Data
	3	SD(TXD)	Output	Send Data
	4	ER(DTR)	Output	Data Terminal Ready
	5	SG	-	Signal Ground
	6	DR(DSR)	Input	Data Set Ready
	7	RS(RTS)	Output	Request to Send
	8	CS(CTS)	Input	Send Possible
	9	CI(RI)/VCC	Input/-	Called status display +5V±5% Output 0.25A ^{*1}
	Shell	FG	-	Frame Ground (Common with SG)

*1. The RI/VCC selection for Pin #9 is switched via software. The VCC output is not protected against overcurrent. To prevent damage or a unit malfunction, use only the rated current.

◆ Serial Interface (COM2)

This interface is used to connect an RS-422/RS-485*¹ serial cable. A D-Sub 9-pin plug connector is used.

<ST unit side>

ST Connector	XM2C-0942-502LX <OMRON Co.>
Interfit Bracket	#4-40 inch screws are used.

<Cable side>

Recommended Cable Connector	XM2D-0901 <OMRON Co.>
Recommended Cable Cover	XM2S-0913 <OMRON Co.>
Recommended Jack Screw	XM2Z-0073 <OMRON Co.>

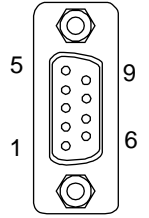
Pin Arrangement	Pin No.	RS-422/RS-485* ¹		
		Signal Name	Direction	Meaning
 <p>(ST unit side)</p>	1	RDA	Input	Receive Data A(+)
	2	RDB	Input	Receive Data B(-)
	3	SDA	Output	Send Data A(+)
	4	ERA	Output	Data Terminal Ready A(+)
	5	SG	-	Signal Ground
	6	CSB	Input	Send Possible B(-)
	7	SDB	Output	Send Data B(-)
	8	CSA	Input	Send Possible A(+)
	9	ERB	Output	Data Terminal Ready B(-)
	Shell	FG	-	Frame Ground (Common with SG)

*1 RS-485 is compliant with ST-3400 series units with revision code "A" or later.

3.3.4 Dimensions

The following dimensions apply to all ST-3400 Series units.

■ Installation Fasteners Attached Dimensions

Unit: mm[in.]

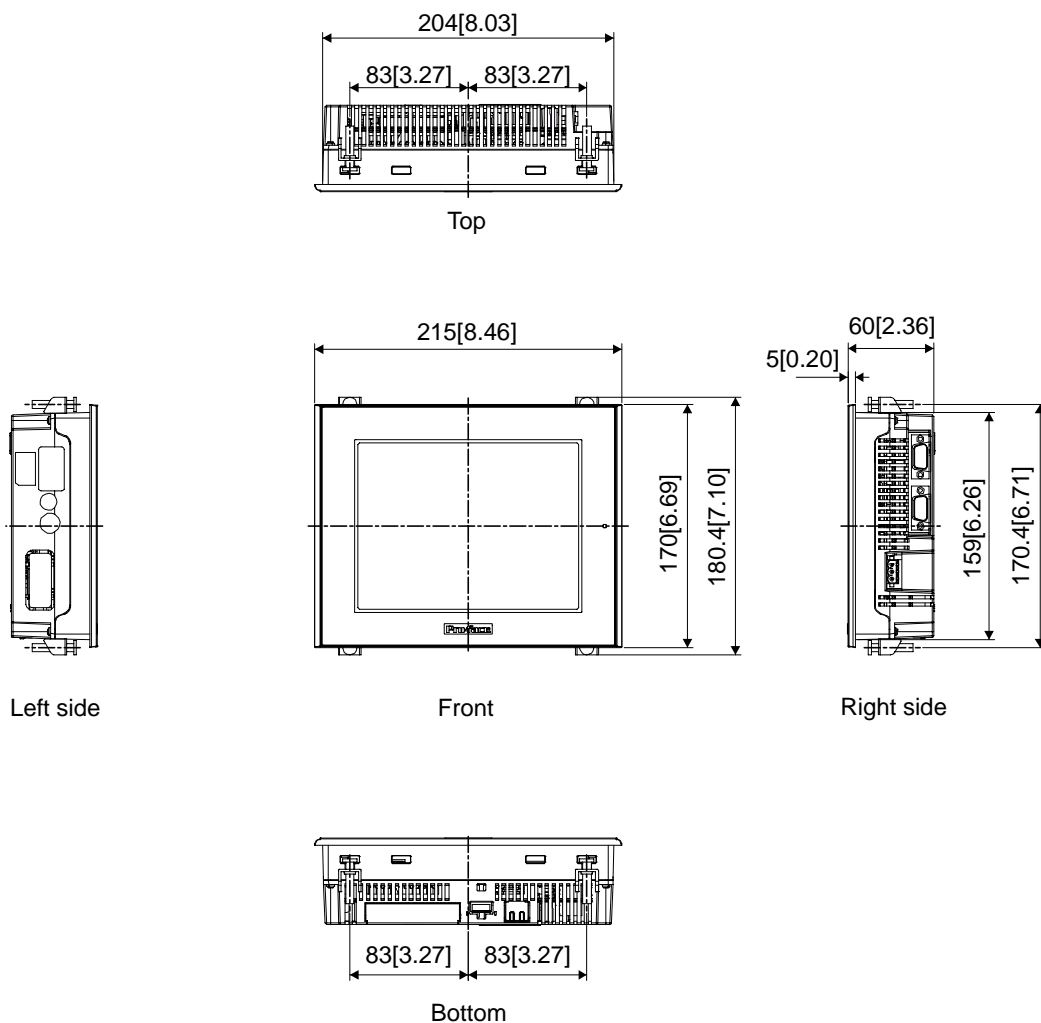

■ Cable Attached Dimensions

Unit:mm[in.]

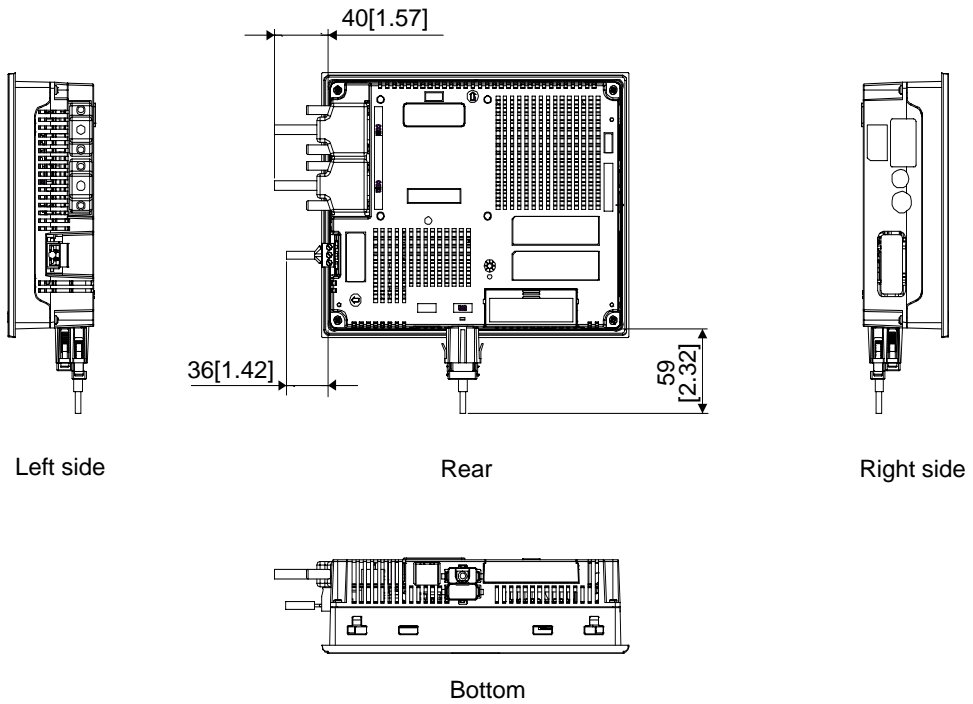

IMPORTANT

- All the above values are designed in case of cable bending. The dimensions given here are representative values depending on the type of connection cable used. Therefore, they are all intended for reference only.

■ Panel Cut Dimensions

Unit: mm[in.]

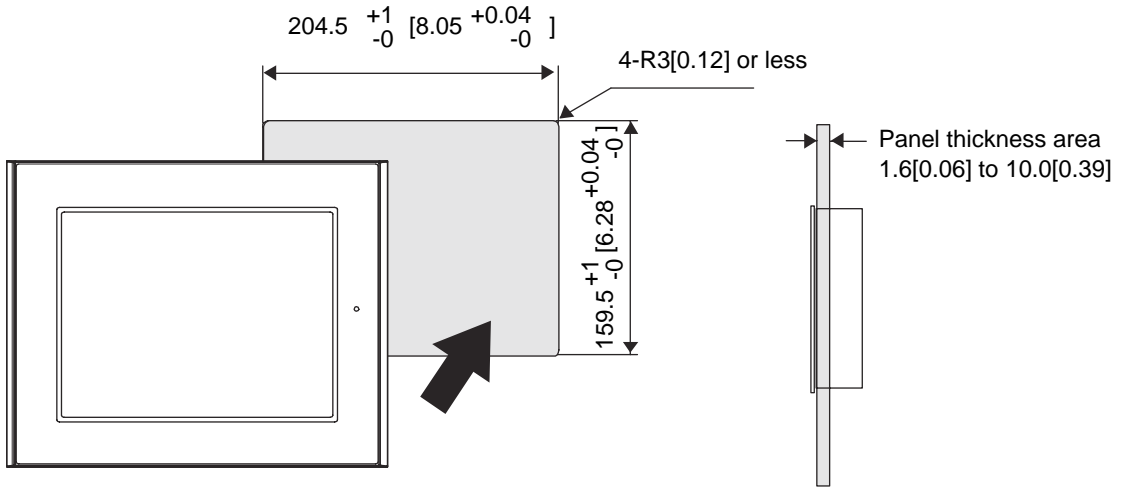

■ Installation Fasteners

Unit: mm[in.]

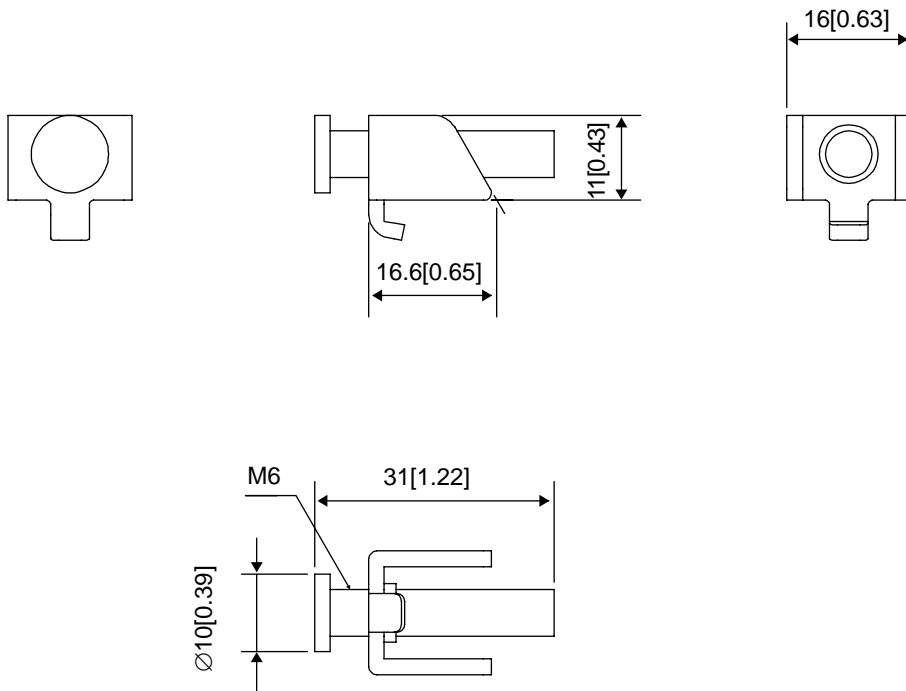

3.4 ST-3500 Series

3.4.1 General Specifications

■ Electrical Specifications

		DC Type	AC Type
Power Supply	Input Voltage	DC24V	AC100 to 240V
	Rated Voltage	DC19.2 to 28.8V	AC85 to 265V
	Rated frequency	-	50/60Hz
	Rated frequency range	-	40 to 72Hz
	Allowable Voltage Drop	10ms or less	1cycle or less (Voltage Drop interval must be 1s or more.)
	Power Consumption	45W or less	AC100V 0.9A or less (TYP 0.48A) AC240V 0.45A or less (TYP 0.26A)
	In-Rush Current	30A or less	60A or less
Voltage Endurance		AC1000V 20mA 1minute	AC1500V 20mA 1minute
Insulation Resistance		DC500V 10M Ω (min.) (between charging and FG terminals)	DC500V 10M Ω (min.) (between charging and FG terminals)

■ Environmental Specifications

Physical	Surrounding Air Temperature	0 to +50°C
	Storage Temperature	-20 to +60°C
	Ambient Humidity	10 to 90% RH (Wet bulb temperature: 39°C max. - no condensation.)
	Storage Humidity	10 to 90% RH (Wet bulb temperature: 39°C max. - no condensation.)
	Dust	0.1mg/m ³ and below (non-conductive levels)
	Pollution Degree	For use in Pollution Degree 2 environment.
	Atmosphere	Free of corrosive gases
	Air Pressure Vibration Resistance (altitude range)	800 to 1114hPa (sea level to 2000 meters above)
Mechanical	Vibration Resistance	IEC61131-2 compliant 5 to 9Hz single-amplitude 3.5mm[0.14in] 9 to 150Hz constant-accelerated velocity 9.8m/s ² X,Y,Z directions for 10 cycle (100 minute)
	Concussion Resistance	IEC61131-2 compliant (147m/s ² X,Y,Z directions for 3 times)
Electrical	Noise Immunity	Noise Voltage: 1000V _{P-P} (DC type) 1500V _{P-P} (AC type) Pulse Duration: 1μs Rise Time: 1ns (via noise simulator)
	Electrostatic Discharge Immunity	6kV (complies with EN 61000-4-2 Level 3)

■ Structural Specifications

Installation	Grounding	Grounding resistance of 100Ω 2mm ² or thicker wire, or your country's applicable standard. (Same for FG and SG terminals)
	Structure *1	Rating: Equivalent to IP65f NEMA #250 TYPE 4X/13 (Front surface at panel embedding) Feature size: All-in-one Installation configuration: Panel embedding
	Cooling Method	Natural air circulation
	Weight Approx.	2.5kg[5.5lb] max. (unit only)
	External Dimensions	W270.5mm[10.65in] X H212.5mm[8.37in] X D57mm[2.24in]
	Panel Cut Dimensions	W259mm[10.20in] X H201mm[7.91in] ^{*2} Panel thickness: 1.6mm[0.06in] to 10.0mm[0.39in]

- *1. The front face of the ST unit, installed in a solid panel, has been tested using conditions equivalent to the standards shown in the specification. Even though the ST unit's level of resistance is equivalent to these standards, oils that should have no effect on the ST can possibly harm the unit. This can occur in areas where either vaporized oils are present, or where low viscosity cutting oils are allowed to adhere to the unit for long periods of time. If the ST's front face protection sheet becomes peeled off, these conditions can lead to the ingress of oil into the ST and separate protection measures are suggested.
Also, if non-approved oils are present, it may cause deformation or corrosion of the front panel's plastic cover. Therefore, prior to installing the ST be sure to confirm the type of conditions that will be present in the ST's operating environment.
If the installation gasket is used for a long period of time, or if the unit and its gasket are removed from the panel, the original level of the protection cannot be guaranteed. To maintain the original protection level, be sure to replace the installation gasket regularly.
- *2. Dimensional tolerance: everything +1/-0mm[+0.04/-0in] and R in angle are below R3[0.12].

3.4.2 Performance Specifications

■ Performance Specifications

Application *1		FLASH EPROM 6MB
Data Backup		SRAM 320KB
		Used lithium battery for backup memory
Interface	Serial Interface	COM1: RS-232C Asynchronous Transmission: Data Length: 7 bit/8 bit Parity: none, Odd or Even Stop Bit: 1bit/2bit Data Transmission Speed: 2400bps to 115.2 kbps Connector: D-Sub 9pin plug
		COM2: RS-422/RS-485*2 Asynchronous Transmission Data Length: 7 bit/8 bit Parity: none, Odd or Even Stop Bit: 1bit/2bit Data Transmission Speed: 2400bps to 115.2 kbps (RS-422/RS-485) 187.5 kbps (MPI) Connector: D-Sub 9pin plug
	USB Host Interface	Complies with USB1.1. (TYPE-A conn.) x 1 Power Supply Voltage: DC5V ± 5% Output Current: 500mA (Max.) Communication Distance: 5m (Max.)
	CF Card Interface	Compact Flash CF Card Slot (TYPE-II)
Clock Accuracy *3		±65 seconds/ month (at room temperature)

*1. User active capacity.

*2. RS-485 is compliant with AST-3501C / AST-3501T with revision code "B" or later.

SEE → *About Revision (page 12)*

*3. The ST's internal clock has a slight error. At normal operating temperatures and conditions, with the ST operating from its lithium battery, the degree of error is 65 seconds per month. Variations in operating conditions and battery life can cause this error to vary from -380 to +90 seconds per month. For systems where this degree of error will be a problem, the user should be sure to monitor this error and make adjustments when required.

NOTE

- When the message “RAAA051 Low battery” is displayed, supply power to the display unit and fully charge the battery. The battery charges within 24 hours to a level which allows backup operation. Completing a full charge requires about 96 hours (4 days).
- A Lithium battery’s lifetime is: 10 years when the battery’s ambient temperature is 40°C or less. 4.1 years when the battery’s ambient temperature is 50°C or less. 1.5 years when the battery’s ambient temperature is 60°C or less.

When used for backup:

Approximately 100 days, with a fully charged battery.

Approximately 6 days, with a half-charged battery.

■ Display Specifications

		AST-3501C	AST-3501T
Display Type		Color LCD	TFT Color LCD
Resolution		W640 X H480 pixels	
Dot pitch		W0.33mm[0.01in] X H0.33mm[0.01in]	
Effective Display Area		W211.2mm[8.31in] X H158.4mm[6.24in]	
Color/Shade level		16 Colors	256 Colors (No blink) 64 Colors (Enables blink feature)
Backlight		CCFL (Not replaceable)	
Brightness control		8 levels of adjustment available via touch panel	
Contrast Adjustment		Not applicable	
Backlight Service Life		50000hrs. or more (at 25°C and continuous operation - period until backlight brightness decreases to 50% or backlight starts to flicker)	
Language Fonts		Japanese: 6962 (JIS Standards 1 & 2) (including 607 non-kanji characters) ANK: 158 (Korean fonts, Simplified Chinese and Taiwanese traditional Chinese fonts are downloadable.)	
Text composition	Character Sizes	Standard font: 8X8, 8X16, 16X16 and 32X32 dot fonts Stroke font: 6 to 127 dot fonts	
	Font Sizes	Standard font: Width can be expanded up to 8 times. Height can be expanded up to 8 times ^{*1}	
Text	8 X 8 dots	80 Char. X 60 rows	
	8 X 16 dots	80 Char. X 30 rows	
	16 X 16 dots	40 Char. X 30 rows	
	32 X 32 dots	20 Char. X 15 rows	

*1. Font Sizes can be set up by software.

■ Touch Panel Specifications

Type	Resistive Film (analog)
Resolution	1024 X 1024
Service Life	1000000 times or more

3.4.3 Interface Specifications

This section describes the specifications of each interface of the ST Series unit.

IMPORTANT

- The ST unit's serial port is not isolated. When the host (PLC) unit is also not isolated, be sure to connect Pin #5 SG (Signal Ground) terminal to reduce the risk of damaging the RS-232C/RS-422/RS-485 circuit.
- ST Series have the SG (signal ground) connection and the FG (frame ground) connection inside. When connecting an external device to the ST using the SG terminal, be sure to check that no short-circuit loop is created when you setup the system.
- The same type of connector is used for COM1 and COM2 of the ST. Be careful not to mistake one for the other. Connecting them incorrectly disables communication.

NOTE

- Connecting the RS-232C isolation unit (CA3-ISO232-01) to COM1 enables isolation if needed.

■ Serial Interfaces

◆ Serial Interface (COM1)

This interface is used to connect an RS-232C serial cable. A D-Sub 9-pin plug connector is used.

<ST unit side>

ST Connector	XM2C-0942-502L <OMRON Co.>
Interfit Bracket	#4-40 inch screws are used.

<Cable side>

Recommended Cable Connector	XM2D-0901 <OMRON Co.>
Recommended Cable Cover	XM2S-0913 <OMRON Co.>
Recommended Jack Screw	XM2Z-0073 <OMRON Co.>

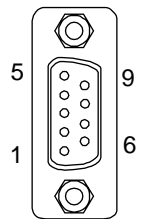
Pin Arrangement	Pin No.	RS-232C		
		Signal Name	Direction	Meaning
 <p>(ST unit side)</p>	1	CD	Input	Carrier Detect
	2	RD(RXD)	Input	Receive Data
	3	SD(TXD)	Output	Send Data
	4	ER(DTR)	Output	Data Terminal Ready
	5	SG	-	Signal Ground
	6	DR(DSR)	Input	Data Set Ready
	7	RS(RTS)	Output	Request to Send
	8	CS(CTS)	Input	Send Possible
	9	CI(RI)/VCC	Input/-	Called status display +5V±5% Output 0.25A ^{*1}
	Shell	FG	-	Frame Ground (Common with SG)

*1 The RI/VCC selection for Pin #9 is switched via software. The VCC output is not protected against overcurrent. To prevent damage or a unit malfunction, use only the rated current.

◆ Serial Interface (COM2)

This interface is used to connect an RS-422/RS-485*1 serial cable. A D-Sub 9-pin plug connector is used.

<ST unit side>

ST Connector	XM2C-0942-502LX <OMRON Co.>
Interfit Bracket	#4-40 inch screws are used.

<Cable side>

Recommended Cable Connector	XM2D-0901 <OMRON Co.>
Recommended Cable Cover	XM2S-0913 <OMRON Co.>
Recommended Jack Screw	XM2Z-0073 <OMRON Co.>

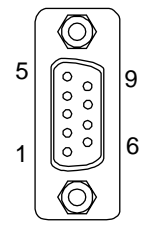
Pin Arrangement	Pin No.	RS-422/RS-485*1		
		Signal Name	Direction	Meaning
 <p>(ST unit side)</p>	1	RDA	Input	Receive Data A(+)
	2	RDB	Input	Receive Data B(-)
	3	SDA	Output	Send Data A(+)
	4	ERA	Output	Data Terminal Ready A(+)
	5	SG	-	Signal Ground
	6	CSB	Input	Send Possible B(-)
	7	SDB	Output	Send Data B(-)
	8	CSA	Input	Send Possible A(+)
	9	ERB	Output	Data Terminal Ready B(-)
	Shell	FG	-	Frame Ground (Common with SG)

*1 RS-485 is compliant with AST-3501C / AST-3501T with revision code "B" or later.

SEE → About Revision (page 12)

3.4.4 Dimensions

The following dimensions apply to all ST-3500 Series units.

■ Installation Fasteners Attached Dimensions

Unit: mm[in.]

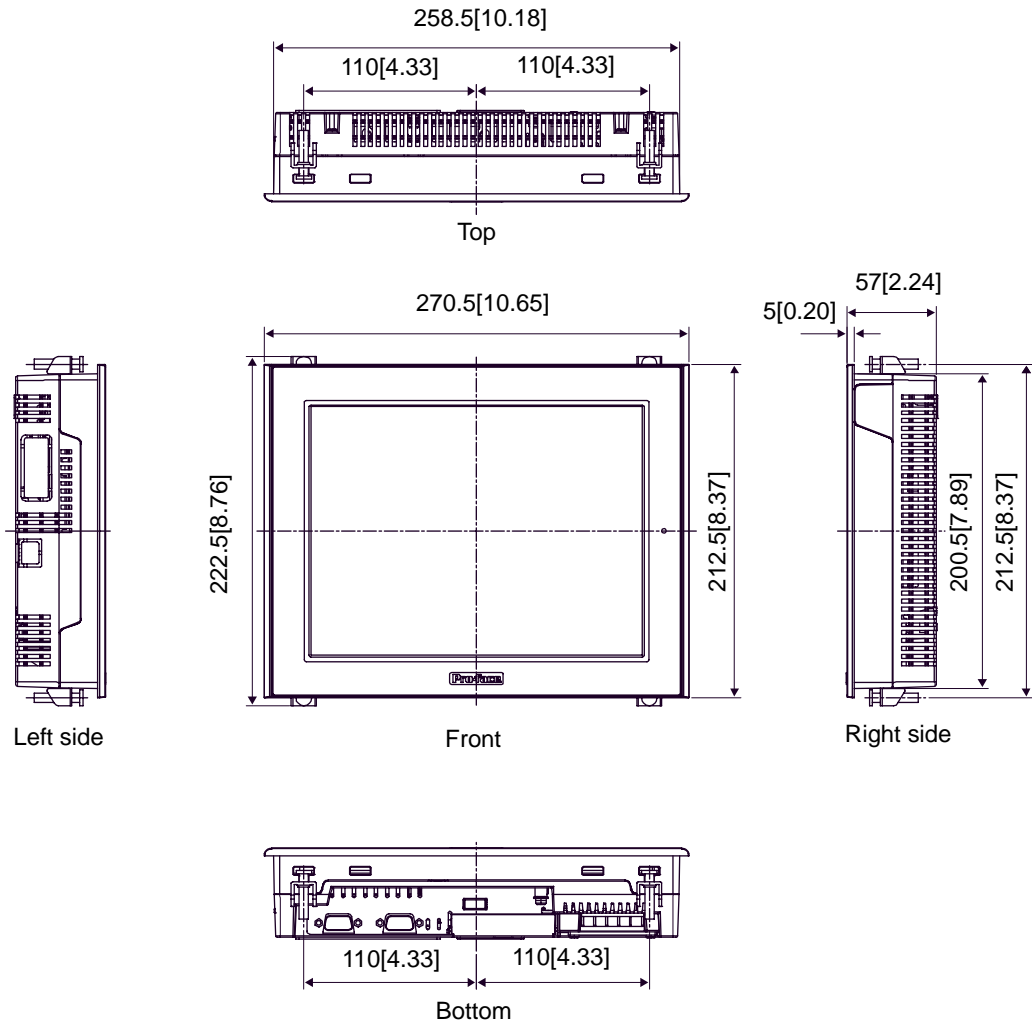

■ Cable Attached Dimensions

Unit:mm[in.]

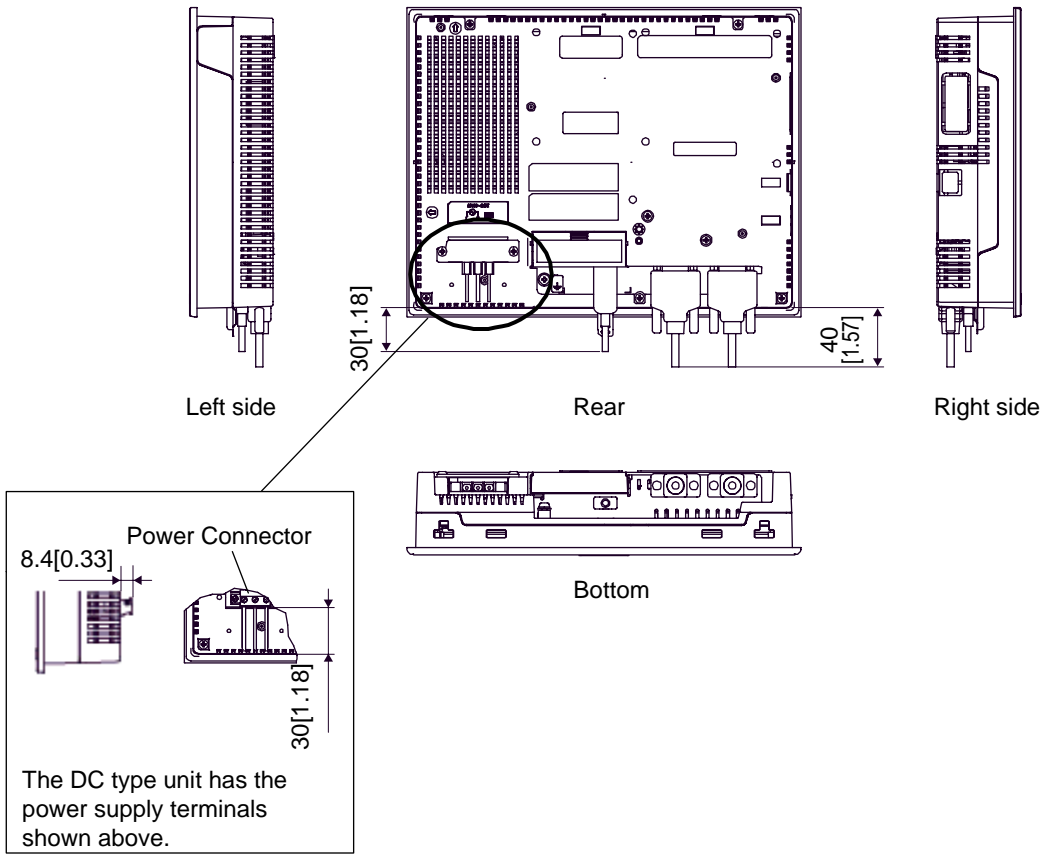

IMPORTANT

- All the above values are designed in case of cable bending. The dimensions given here are representative values depending on the type of connection cable used. Therefore, they are all intended for reference only.

■ Panel Cut Dimensions

Unit: mm[in.]

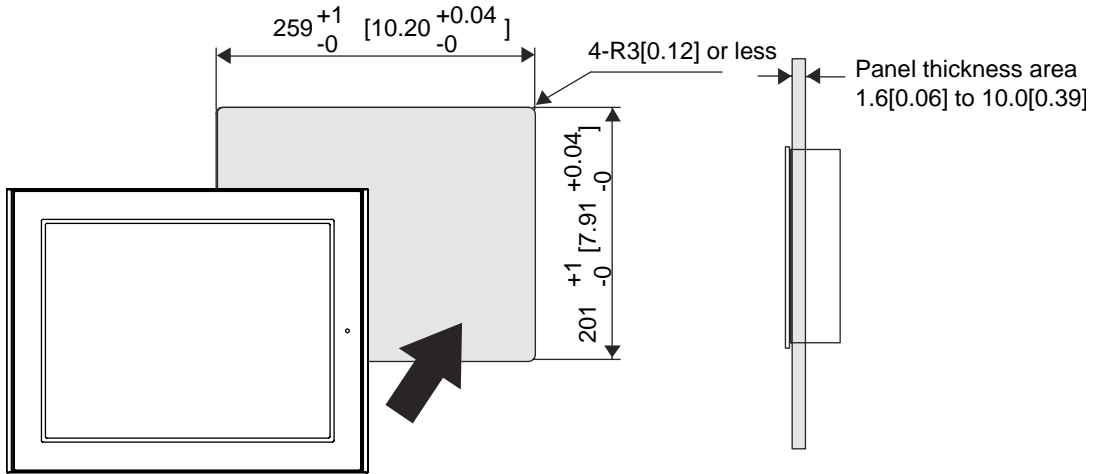

■ Installation Fasteners

Unit: mm[in.]

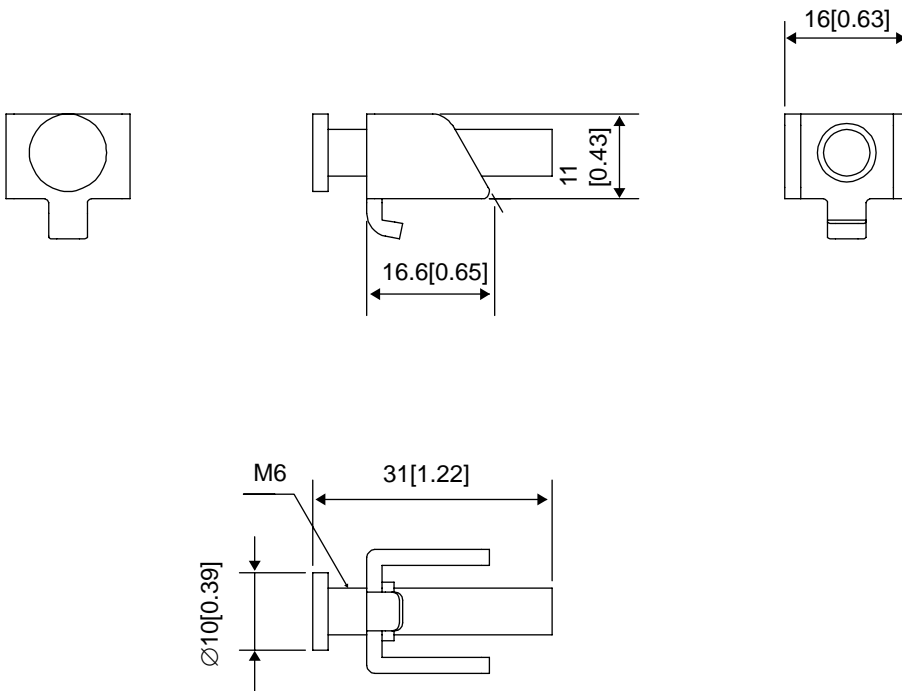

4

Installation and Wiring

1. Installation
2. Wiring Precautions
3. CF Card Insertion/Removal
4. USB Cable Clamp Attachment/Removal

This chapter describes the installation and cable arrangement of the ST Series and its peripheral equipment.

4.1 Installation

This section describes the procedures and precautions for installing the ST Series units.

■ Check the Installation Gasket's Seal

It is strongly recommended that you use the installation gasket, since it absorbs vibration in addition to repelling water.

For the procedure for attaching the installation gasket, refer to "[5.3 Replacing the Installation Gasket](#)".

SEE → [5.3 Replacing the Installation Gasket \(page 5-4\)](#)

IMPORTANT

- Before installing the ST into a cabinet or panel, check that the installation gasket is securely attached to the unit.
- A gasket which has been used for a long period of time may have scratches or dirt on it, and could have lost much of its dust and drip resistance. Be sure to change the gasket periodically (or when scratches or dirt become visible).

■ Creating a Panel Cut

Create the correct sized opening required to install the ST, using the installation dimensions given.

Determine the panel thickness according to the panel thickness range with due consideration of panel strength.

SEE → [ST-3200 Series](#)
 ■ [Panel Cut Dimensions \(page 3-13\)](#)
[ST-3300 Series](#)
 ■ [Panel Cut Dimensions \(page 3-25\)](#)
[ST-3400 Series](#)
 ■ [Panel Cut Dimensions \(page 3-35\)](#)
[ST-3500 Series](#)
 ■ [Panel Cut Dimensions \(page 3-47\)](#)

NOTE

- Check that the installation panel or cabinet's surface is flat, in good condition and has no jagged edges. Also, if desired, metal reinforcing strips can be attached to the inside of the panel, near the Panel Cut, to increase the panel's strength.

■ Installation Requirement

- For easier maintenance, operation, and improved ventilation, be sure to install the ST at least 100 mm [3.94 in.] away from adjacent structures and other equipment.

Unit: mm[im.]

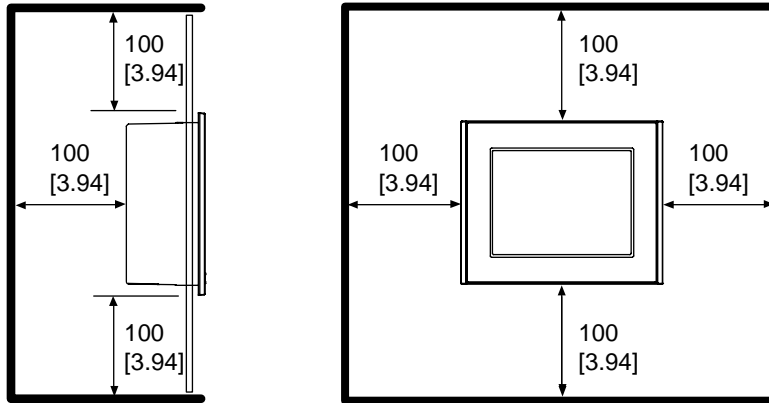

- Be sure that the ambient operation temperature and the ambient humidity are within their designated ranges. (Ambient operation temperature: 0 to 50°C, Ambient humidity: 10 to 90%RH, Wet bulb temperature: 39°C max.) When installing the ST on the panel of a cabinet or enclosure, “Ambient operation temperature” indicates both the panel face and cabinet or enclosure’s internal temperature.

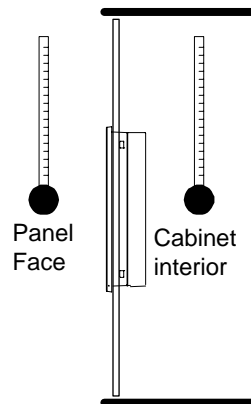

- Be sure that heat from surrounding equipment does not cause the ST to exceed its standard operating temperature.

- When installing the ST in a slanted panel, the panel face should not incline more than 30°.

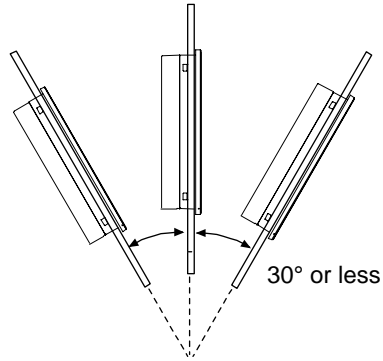

- When installing the ST in a slanted panel, and the panel face inclines more than 30°, the ambient temperature must not exceed 40°C. You may need to use forced air cooling (fan, A/C) to ensure the ambient operating temperature is 40°C or below.
- When installing the ST vertically, position the unit so that the Power Input Terminal Block is also vertical.

■ Installing the ST

(1) Insert the ST into the panel cut, as shown.

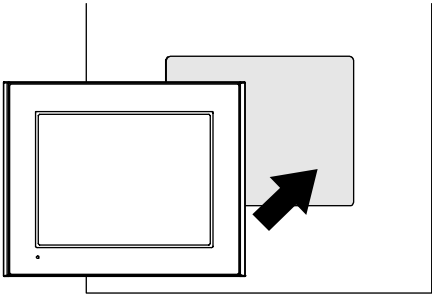

(2) Mount the four panel-mounting brackets on the right and left sides, or the top and bottom sides of the panel to secure the panel.

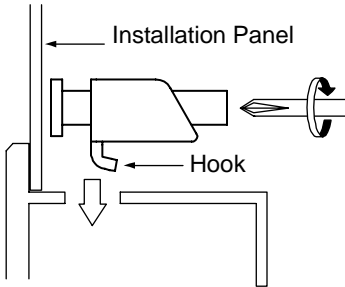

Models that have the mounting bracket holes on the sides
(The drawing below is the ST-3200 series.)

Models that have the mounting bracket holes on the top and bottom
(The drawing below is the ST-3300 series.)

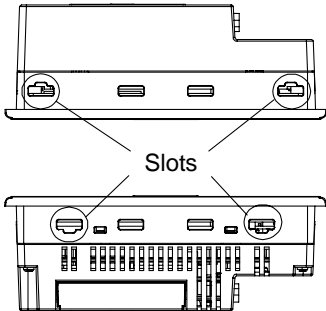
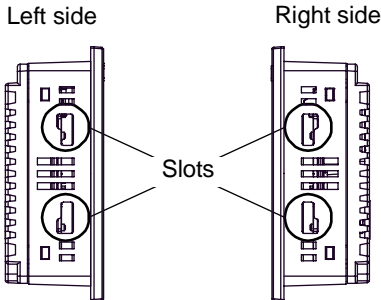

IMPORTANT

- Be sure to insert installation fasteners in the recessed portion of the installation fasteners hole (see shaded areas in the following figure). If the fasteners are not correctly attached, the ST unit may shift or fall out of the panel.



- (3) Insert each of the fasteners as shown below. Be sure to pull the fastener back until it is flush with the rear of the attachment hole.

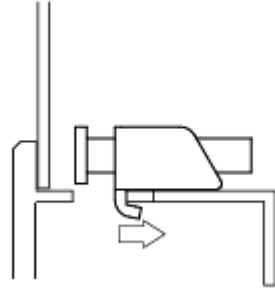

- (4) Use a Phillips screwdriver to tighten each fastener screw and secure the ST in place.

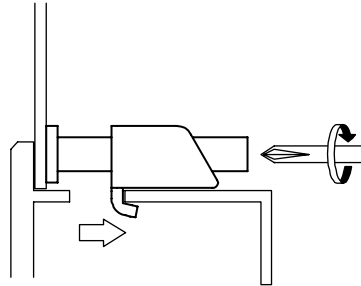

IMPORTANT





- Tightening the screws with too much force can damage the ST unit's plastic case.
- The torque required to tighten these screws is 0.5 N•m.

4.2 Wiring Precautions

This section describes the procedures and precautions for wiring power cords.

4.2.1 Connecting the Power Cord

WARNING

-  To avoid an electric shock, prior to connecting the ST unit's power cord terminals to the power terminal block, confirm that the ST unit's power supply is completely turned OFF, via a breaker, or similar unit.
-  Supplying a power voltage other than that specified will damage the power source and the ST unit.
-  Since there is no power switch on the ST unit, be sure to attach a breaker-type switch to its power cord.
-  When the FG terminal is connected, be sure the wire is grounded.

IMPORTANT

- When the FG terminal is connected, be sure the wire is grounded. Not grounding the ST unit will result in excess noise and vibration.
- ST Series (except AST-3211A, AST-3302B COM2) have the SG (signal ground) connection and the FG (frame ground) connection inside.
When connecting the SG wire to another device, be sure that the design of the system/connection does not produce a ground loop.

■ When using the AC Type

◆ Power Cord Specifications

	AC Power Cord	Grounding Wire
Power Cord	Double-insulated Wire 1.25 to 2.0mm ² (16-14 AWG)	1.25 to 2.0mm ² (16-14 AWG)
Recommended Ring Terminal *1	V2-MS3 compatible (J.S.T. Mfg. Co., Ltd.) Ø3.2mm [0.13in.] or more less than 6.0mm [0.24in.]	V2-P4 compatible (J.S.T. Mfg. Co., Ltd.) Ø4.3mm [0.17in.] or more less than 7.0mm [0.28in.]

*1. In order to prevent a short circuit caused by loose screws, make sure to use a crimp-type terminal with insulating sleeve.

◆ Connecting the Power Cord

When connecting the AC type power cord, be sure to follow the procedures given below.

- (1) Be sure that the ST's power cord is not plugged in to the power supply.
- (2) Remove the Terminal Strip's clear plastic cover.
- (3) Remove the screws from the two (2) terminals (L, N) and FG (Frame Ground) terminal, position the Ring Terminals and reattach the screws. (Check each wire to make sure the connections are correct.)

IMPORTANT

- The torque required to tighten these screws are as follows:
Terminal Block: 0.5 to 0.6N•m [5-7Lb•In.]
FG (Frame Ground) Terminal: 0.6 to 0.7N•m

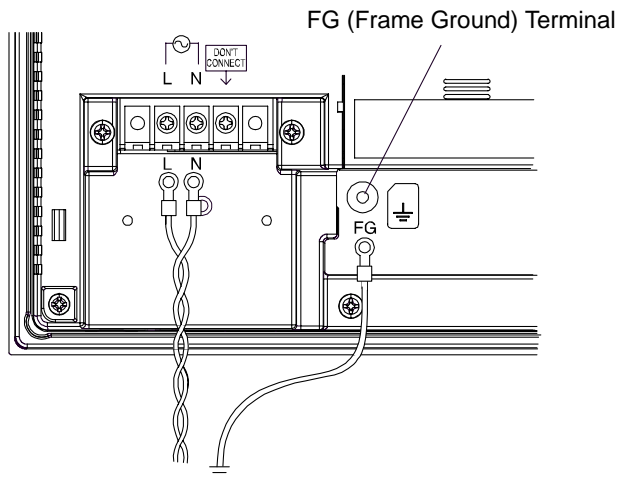

- (4) Reattach the Terminal Strip's clear plastic cover.

■ When using the DC Type

◆ Power Cord Specifications

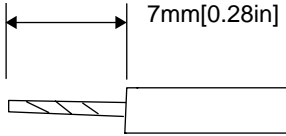
Power Cord Diameter	0.75 to 2.5mm ² (18-12AWG)
Conductor Type	Solid or Twisted Wire
Conductor Length	

IMPORTANT

- Use copper conductors only.
- If the Conductor's end (individual) wires are not twisted correctly, the end wires may either short against each other, or against an electrode.

◆ Power Connector (Plug) Specifications

When using the ST-3200/3300/3400 Series

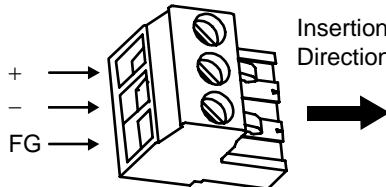
	+	24V
	-	0V
	FG	FG Grounding Terminal connected to the ST

NOTE

- The power supply connector (plug) is CA5-DCCNM-01 (made by Pro-face) or MSTB2,5/3-ST-5,08 (made by Phoenix Contact^{*1}).

*1. For details, please contact your local Phoenix Contact distributor.

When using the ST-3500 Series

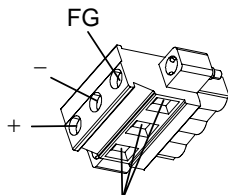
 <p>Power Cord Insertion Holes</p>	+	24V
	-	0V
	FG	FG Grounding Terminal connected to the ST

NOTE

- The power supply connector (plug) is CA5-DCCNL-01 (made by Pro-face) or GMVSTBW2, 5/3-STF-7, 62 (made by Phoenix Contact^{*1}).

*1. For details, please contact your local Phoenix Contact distributor.

◆ Wiring

When connecting the Power Cord, use the following items when performing wiring. (Items are made by Phoenix Contact.)

Recommended Driver	SZF 1-0.6x3.5 (1204517)
Recommended Pin Terminals	AI 0.75-8GY (3200519) AI 1-8RD (3200030) AI 1.5-8BK (3200043) AI 2.5-8BU (3200522)
Recommended Pin Terminal Crimp Tool	CRIMPFOX ZA3 (1201882)

◆ Connecting the Power Cord

IMPORTANT

- Be sure to remove the connector from the ST unit prior to starting wiring. Failure to do so may cause an electric shock.
- The temperature rating of field installed conductors: 75°C only.

When using the ST-3200/3300/3400 Series

- (1) Confirm that the power cord is unplugged from the power supply.
- (2) Remove the power connector (plug) from the main unit when using the ST-3200/3300 Series. (When using ST-3400 Series, the power connector (plug) is packaged with other accessories.)
- (3) Strip the sheath of the power cord, twist the wire ends, and connect them to the Power Connector.

IMPORTANT

- Use a slot screwdriver (Size 0.6 X 3.5) to tighten the terminal screws. The torque required to tighten these screws is 0.5 to 0.6N•m [5-7Lb•In.].
- Do not solder the cable connection.

- (4) Reattach the Power Connector.

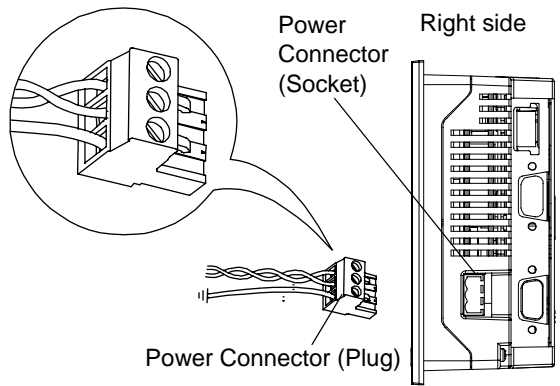

(The drawing on the left is the ST-3300 Series.)

NOTE

- Be sure to twist the power cords together, up to the power connector.

When using the ST-3500 Series

- (1) Confirm that the power cord is unplugged from the power supply.
- (2) Remove the power connector (plug) from the main unit.
- (3) Loosen the three screws in the center of the Power Connector (plug).
- (4) Strip the sheath of the power cord, twist the wire ends, insert them into the bar terminals.
- (5) Attach them with screws.

IMPORTANT

- Use a slot screwdriver (size 0.6 x 3.5) to tighten the terminal screws.
The torque required to tighten these screws is 0.5 to 0.6N•m [5-7Lb•In.]
- Do not solder the cable connection.

NOTE

- Be sure to twist the power cords together, up to the power connector.

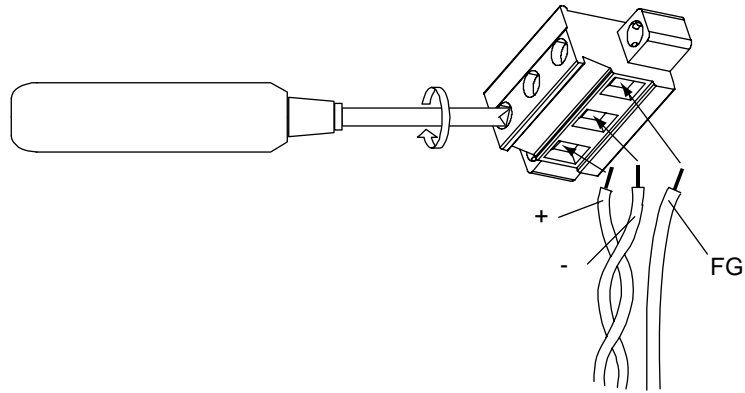

- (6) Attach the Power Connector (Plug) to the ST and attach it to the ST main unit with the right/left tightening screws.

4.2.2 Connecting the Power Supply

This section describes the precautions for supplying a power voltage.

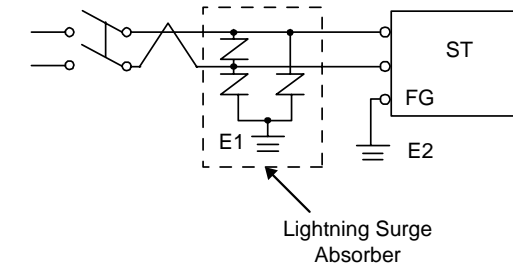
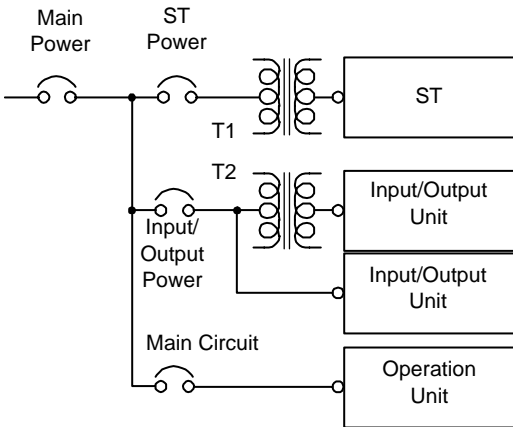
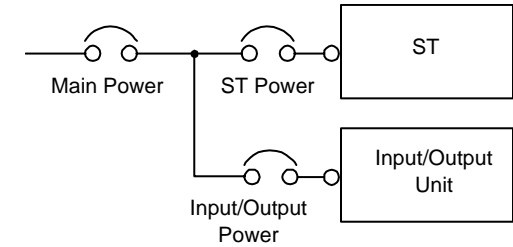
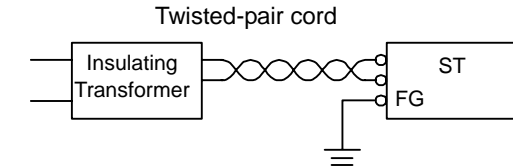
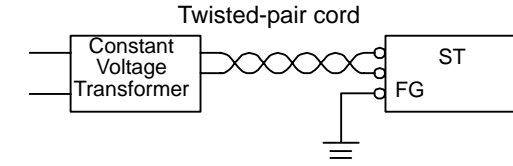

- If the supplied voltage exceeds the ST unit's range, connect a constant voltage transformer.

SEE → Chapter 3 Specifications (page 3-1)

- Between the line and ground, select a power supply that is low in noise. If there is an excess amount of noise, connect an insulating transformer.

IMPORTANT • Use constant voltage and insulating transformers with capacities exceeding Power Consumption value.

- When supplying power to the ST unit, be sure to separate the input/output and power lines, as shown.
- To increase the noise resistance quality of the power cord, simply twist each power wire before attaching the Ring Terminal.
- The power supply cable must not be bundled or positioned close to main circuit lines (high voltage, high current), or input/output signal lines.
- Connect a lightning surge absorber, as shown in the diagram, to deal with power surges.
- To avoid excess noise, make the power cord as short as possible.
- DC24V input unit is must be used with a Class 2 power supply.

IMPORTANT • Be sure to ground the surge absorber (E1) separately from the ST unit (E2).

• Select a surge absorber that has a maximum circuit voltage greater than that of the peak voltage of the power supply.

4.2.3 Grounding

This section describes the precautions for grounding the ST unit.

⚠ CAUTION

❗ Do not use common grounding, since it can lead to an accident or machine breakdown.

(a) Exclusive Grounding (BEST)

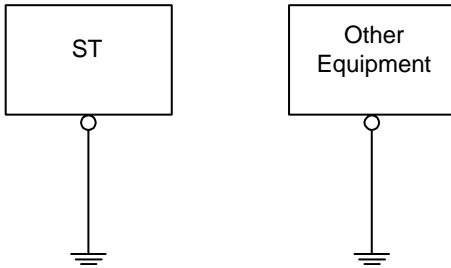

• When supplying power to the ST unit, be sure to separate the input/output and power lines, as shown. [diagram (a)]

IMPORTANT

- Check that the grounding resistance is 100Ω or less.
- FG and SG terminals are internally connected in the ST. When connecting an external device to the ST using the SG terminal, be sure to check that no short-circuit loop is created when you setup the system.
- The grounding wire should have a cross sectional area greater than 2mm^2 . Create the grounding point as close to the ST unit as possible, and make the wire as short as possible. When using a long grounding wire, replace the thin wire with a thicker wire, and place it in a duct.

(b) Exclusive Grounding (OK)

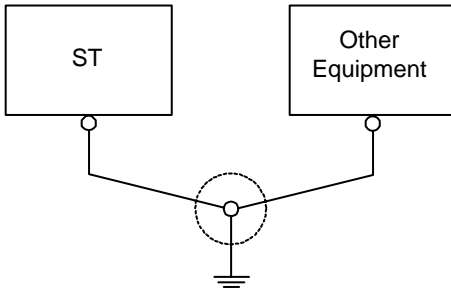

- If exclusive grounding is not possible, use a common grounding point. [diagram (b)] A D-type grounding or equivalent should be used for the grounding point.

(c) Common Grounding (Not OK)

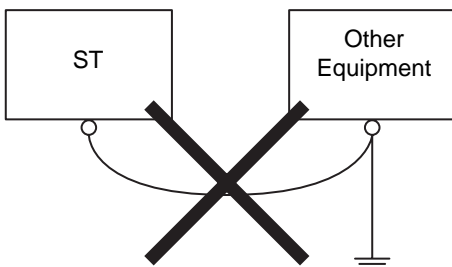

NOTE

- If the equipment does not function properly when grounded, disconnect the ground wire from the FG terminal.

4.2.4 I/O Signal Line Placement

- Input and output signal lines must be separated from the power control cables for operating circuits.
- If this is not possible, use a shielded cable and connect the shield to the ST unit's frame.

4.3 CF Card Insertion/Removal

This section describes how to insert and remove a CF Card.

⚠ CAUTION

When using the ST Unit and a CF Card, observe the following precautions:

- ⊘ Prior to inserting or removing a CF Card, be sure to turn the ST unit's CF Card ACCESS switch OFF and to confirm that the ACCESS lamp is not lit. If you do not, the CF Card's internal data may be damaged or lost.
- ⊘ While a CF Card is being accessed (Status LED: Blinking in green), NEVER turn OFF or reset the ST, or insert or remove the CF Card. If you do, the CF Card's internal data may be damaged or lost.
- ❗ Prior to inserting a CF Card, familiarize yourself with the CF Card's front and rear face orientation, as well as the CF Card connector's position. If the CF Card is not correctly positioned when it is inserted into the Multi Unit, the CF Card's internal data and the ST unit may be damaged or broken.
- ❗ Be sure to use only CF Cards manufactured by Pro-face. The CF Card's internal data may be damaged when using another manufacturer's CF Card.
- ❗ Once ST data is lost, it cannot be recovered. Since accidental data loss can occur at any time, be sure to back up all ST screen and CF Card data regularly.
- ⊘ Be sure to follow the instructions given below to prevent the CF Card's internal data from being destroyed or a CF Card malfunction from occurring:
 - DO NOT bend the CF Card.
 - DO NOT drop or strike the CF Card against another object.
 - Keep the CF Card dry.
 - DO NOT touch the CF Card connectors.
 - DO NOT disassemble or modify the CF Card.

4.3.1 Inserting the CF Card

Use the following steps to insert the CF Card in the ST.

- (1) Pull the CF Card Cover frontward and then open it upward.

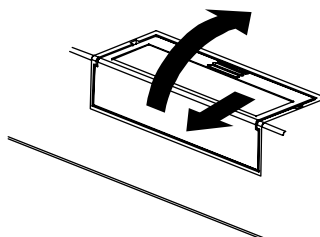

- (2) Insert the CF Card in the CF Card Slot, until the eject button is pushed forward.

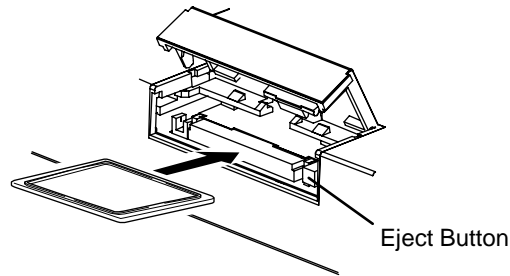

- (3) Close the cover. (As shown.)

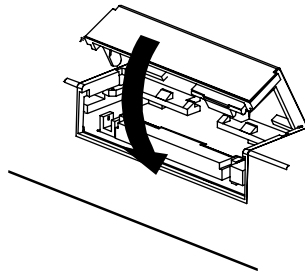

NOTE

- Make sure that the CF Card cover is closed when accessing the CF Card.

4.3.2 Removing the CF Card

Simply reverse the steps shown in the previous “Inserting CF Card” explanation. Prior to pressing the eject button to remove the CF Card, confirm that the CF Card Access LED is turned OFF.

4.3.3 CF Card Handling

The CF Card has a data overwrite limit of approximately 100000 times. Therefore, be sure to back up all CF Card data regularly to another storage media. (100000 times assumes the overwriting of 500KB of data in DOS format.) Two methods are available for backing up data. After using either method (1) or method (2), use your personal computer to save your data to the CF Card.

- (1) If your PC is equipped with a PC Card Slot

To view CF Card data on a personal computer, first insert the CF Card into a CF Card Adapter (GP077-CFAD10), then insert the adaptor in the PC card slot of the PC.

- (2) If your PC is NOT equipped with a PC Card slot

Use a commercially available PC Card Reader, or a CF Card Reader.

4.4 USB Cable Clamp Attachment/Removal

This clamp is used to prevent the USB cable connected to the USB Host Interface on the bottom of the ST unit from being unplugged due to vibration or other causes.

4.4.1 When using the ST-3200/3400 series

■ Attachment

- (1) Before starting the procedure, lift up the tab on both sides of the USB Holder and remove the USB Cover.

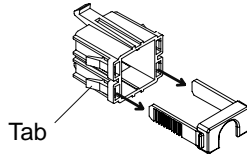

- (2) Attach the USB holder to the USB Host Interface part of the main unit. Hook a pick of the USB holder to the attachment hole of the main unit and then insert the other (lower) pick to attach the USB holder.

ST-3200 Series

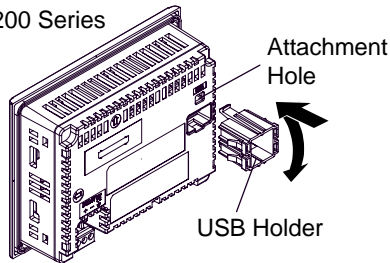

ST-3400 Series

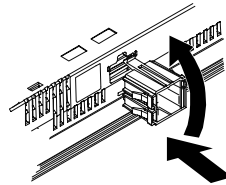

- (3) Insert the USB cable into the USB Host Interface.

ST-3200 Series

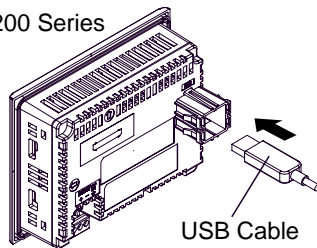

ST-3400 Series

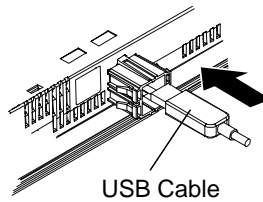

- (4) Attach the USB cover to attach the USB cable. Insert the USB cover into the tab of the USB holder.

ST-3200 Series

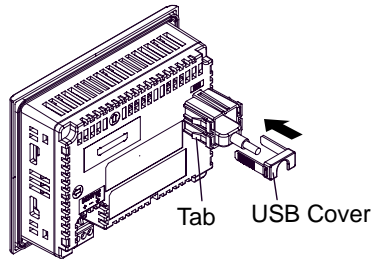

ST-3400 Series

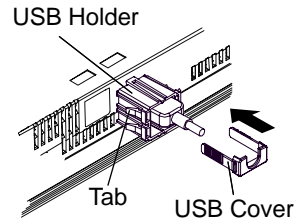
**IMPORTANT**

- Check the up/down orientation of the USB cover to ensure that the USB cable is secured properly.

■ Removal

- (1) Lift up the tab of the USB holder and then remove the USB cover as shown below.

ST-3200 Series

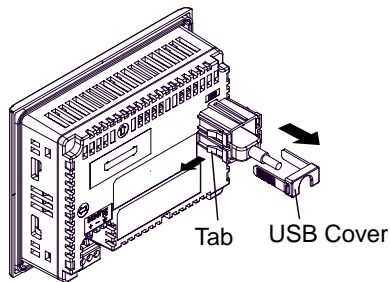

ST-3400 Series

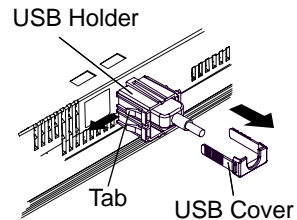

- (2) After removing the USB cable, remove the picks pushing the USB holder from both top and bottom.

4.4.2 When using the ST-3300 series

■ Attachment

- (1) Insert the USB holder into the slot in front of the ST unit's USB port and pull it down and forward.

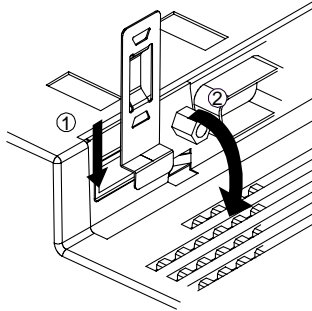

- (2) Pass the band of the USB cable clamp through the bridge of the USB holder.

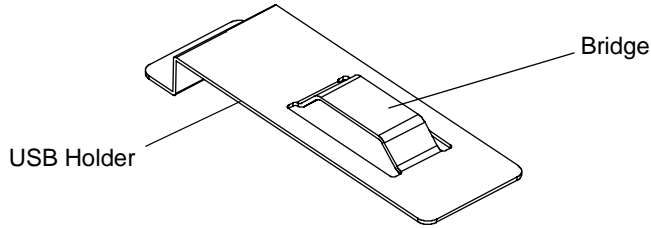

- (3) Insert the USB cable into the port. Fasten the band around the plug and secure it with the clamp.

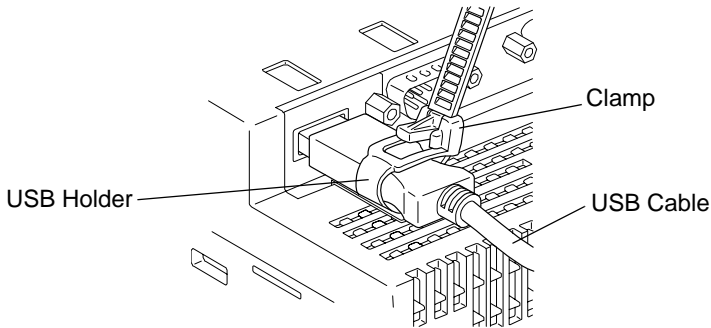

■ Removal

To remove the clamp from the USB cables, push down on the clamp strap's clip to release it while pulling up on the clamp.

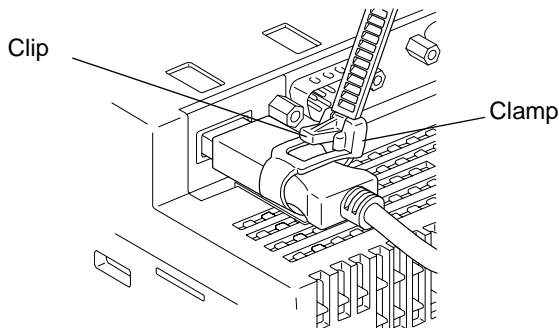

4.4.3 When using the ST-3500 series

■ Attachment

- (1) Insert the USB holder into the slot in front of the ST unit's USB port and pull it down and forward.

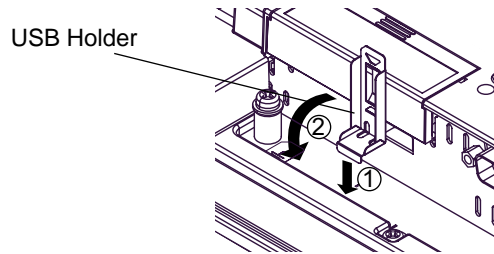

- (2) Pass the band of the USB cable clamp through the bridge of the USB holder.

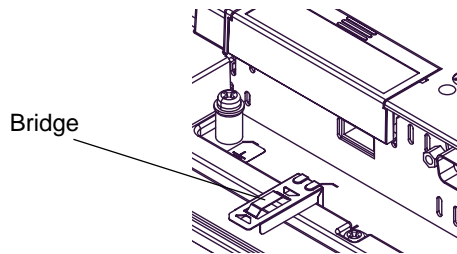

- (3) Insert the USB cable into the port. Fasten the band around the plug and secure it with the clamp.

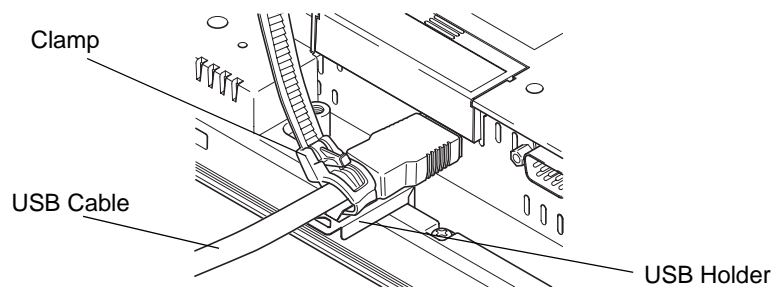

■ Removal

To remove the clamp from the USB cables, push down on the clamp strap's clip to release it while pulling up on the clamp.

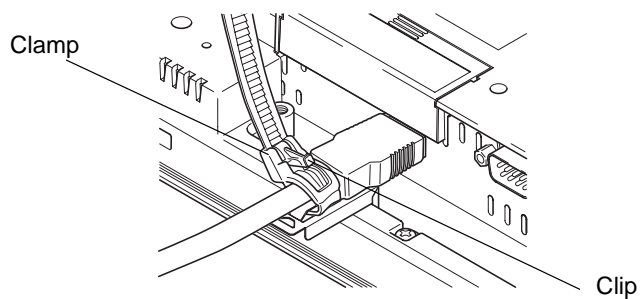

5

Maintenance

1. Cleaning the Display
2. Periodic Check Points
3. Replacing the Installation Gasket
4. Replacing the Backlight

This chapter explains cautions and inspection criteria that will ensure trouble-free use of the ST.

5.1 Cleaning the Display

When the surface or frame of the display become dirty, soak a soft cloth in water with a neutral detergent, wring the cloth tightly, and wipe the display.

IMPORTANT

- Do not use paint thinner, organic solvents, or a strong acid compound to clean the unit.
- Do not use a hard or pointed object to operate the touch-screen panel, since it can damage the panel surface.

5.2 Periodic Check Points

To keep your ST unit in its best condition, please inspect the following points periodically.

■ ST Operation Environment

- Is the operating temperature within the allowable range (0°C to 50°C)?
- Is the operating humidity within the specified range (10%RH to 90%RH, dry bulb temperature of 39°C or less)?
- Is the operating atmosphere free of corrosive gasses?

When using the ST unit inside a panel, the ambient environment refers to the interior of the panel.

■ Electrical Specifications

- Is the input voltage appropriate?

AC85 to 265V 50/60Hz

DC19.2 to 28.8V

■ Related Items

- Are all power cords and cables connected properly? Have any become loose?
- Are all mounting brackets holding the unit securely?
- Are there many scratches or traces of dirt on the installation gasket?

5.3 Replacing the Installation Gasket

The installation gasket provides protection against dust and moisture.

IMPORTANT

- A gasket which has been used for a long period of time may have scratches or dirt on it, and could have lost much of its water resistance. Be sure to change the gasket at least once a year, or when scratches or dirt become visible.
- The ST unit installation gasket's model number is as follows.

ST-3200 Series	ST400-WP01
ST-3300 Series	CA3-WPG6-01
ST-3400 Series	CA5-WPG8-01
ST-3500 Series	CA5-WPG10-01

■ Installation Gasket Attachment Procedure

- (1) Place the ST on a flat, level surface facing the display face downwards.
- (2) Remove the gasket from the ST.
- (3) Attach the new gasket to the ST. Be sure to insert the gasket into the ST's groove so that the gasket's groove sides are vertical.

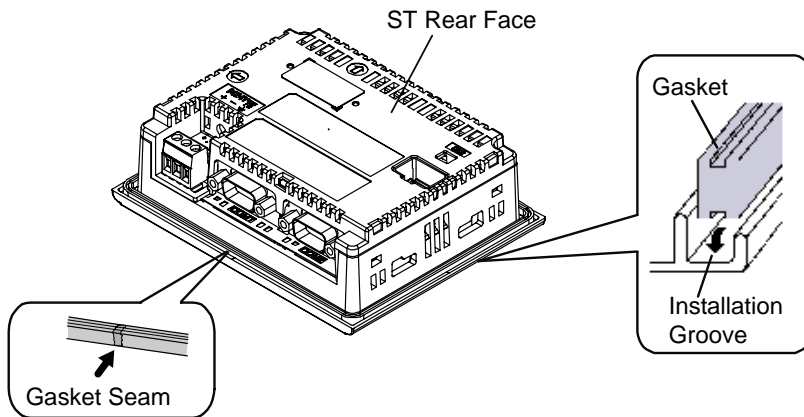

- (4) Check that the gasket is attached correctly to the ST.

IMPORTANT

- The gasket must be inserted correctly into the groove for the ST's moisture resistance to be equivalent to IP65f.
- Since the gasket is flexible but not elastic, be careful not to stretch it unnecessarily, as doing so could tear the gasket.
- Be sure the gasket's seam is not inserted into any of the unit's corners, only in the straight sections of the groove. Inserting it into a corner may lead to its eventually tearing.
- To ensure stable resistance against dust and moisture, insert the gasket so that the seam is at the bottom of the ST unit.
- The upper surface of the gasket should protrude approximately 2.0mm[0.08in] out from the groove. Be sure to check that the gasket is correctly inserted before installing the ST into a panel.

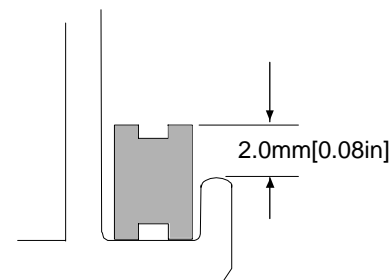

5.4 Replacing the Backlight

The backlights of the ST3000 Series are not replaceable. Although the backlights used are a long-life type, their lifetime may be shorter than the specified period depending on the ST3000 Series operating environment. We would like to replace the displays instead of replacing the backlights. Please contact your Pro-face local distributor.