

MODBUS SLAVE Driver

1	System Configuration.....	3
2	Selection of External Device	9
3	Example of Communication Setting.....	10
4	Setup Items.....	18
5	Cable Diagram	27
6	Supported Device.....	40
7	Device Code and Address Code.....	42
8	Error Messages.....	43
9	Command Format	44

Introduction

This manual describes how to connect the Display and the External Device.

In this manual, the connection procedure will be described by following the below sections:

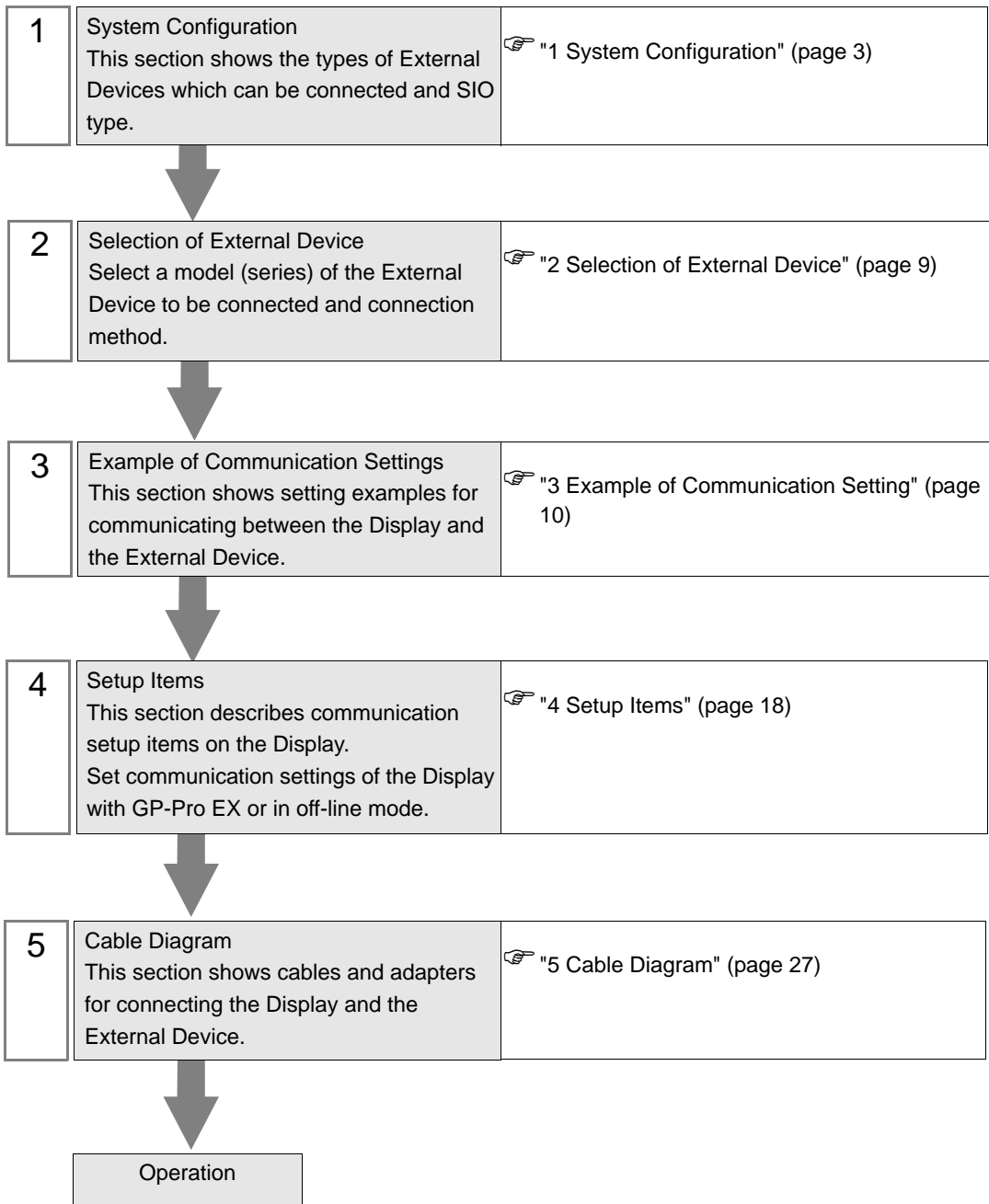

1 System Configuration

The system configuration in the case when the External Device of Shneider Electric Industries and the Display are connected is shown.

■ Serial

Series	CPU	Link I/F	SIO Type	Setting Example	Cable Diagram
MODBUS Series	MODBUS Master Type	Serial Port	RS422/485 (2wire)	"3.1 Setting Example 1" (page 10)	" Cable Diagram 1" (page 27)
			RS232C	"3.2 Setting Example 2" (page 12)	" Cable Diagram 2" (page 34)
			RS422/485 (4wire)	"3.3 Setting Example 3" (page 14)	" Cable Diagram 3" (page 35)

■ Ethernet (TCP)

Series	CPU	Link I/F	SIO Type	Setting Example
MODBUS Series	MODBUS Master Type	Ethernet Port	Ethernet (TCP)	"3.4 Setting Example 4" (page 16)

■ Connection Configuration

- NOTE**
- When using this driver at a communication speed of 38400 or more, there are the following limitations as listed below.
 - The DH-485 driver of Rockwell Automation, Inc. cannot be used simultaneously.
 - SIMATIC S7 MPI direct driver of Siemens AG cannot be used simultaneously.
 - This driver (communication speed: 38400 or more) cannot be used with both COM1 and COM2.

- Serial

[Connection example 1:1]



[Connection example n:1]

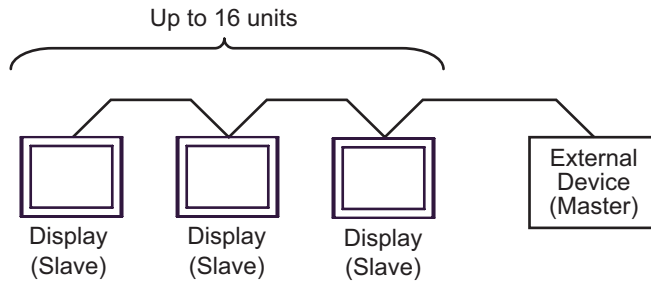

You can connect maximum 16 units of Display (Slave).

- Ethernet (TCP)

[Connection example 1:1]

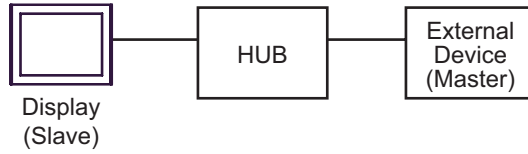

[Connection example n:1]

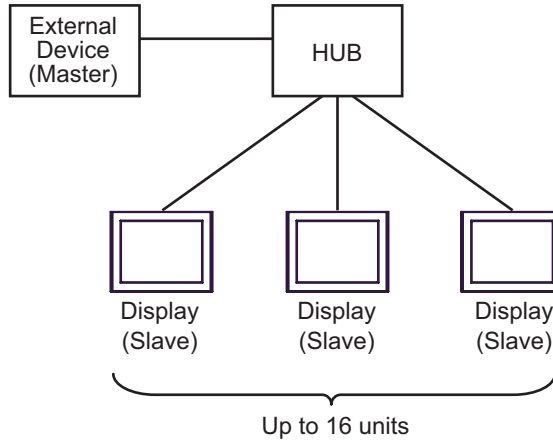

You can connect maximum 16 units of Display (Slave).

[Connection example 1:m]

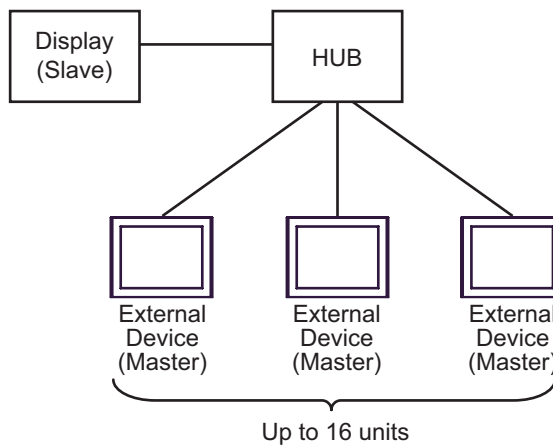

You can connect maximum 16 units of External Device (Master).

[Connection example n:m]

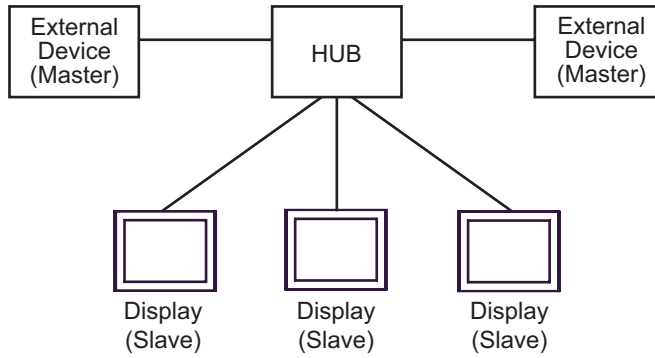

You can connect maximum 16 units of External Device (Master). Note that there is no communication between the Displays (Slaves).

■ IPC COM Port

When connecting IPC with an External Device, the COM port used depends on the series and SIO type. Please refer to the IPC manual for details.

Usable port

Series	Usable Port		
	RS-232C	RS-422/485(4 wire)	RS-422/485(2 wire)
PS-2000B	COM1 ^{*1} , COM2, COM3 ^{*1} , COM4	-	-
PS-3450A, PS-3451A, PS3000-BA, PS3001-BD	COM1, COM2 ^{*1*2}	COM2 ^{*1*2}	COM2 ^{*1*2}
PS-3650A, PS-3651A	COM1 ^{*1}	-	-
PS-3700A (Pentium®4-M) PS-3710A	COM1 ^{*1} , COM2 ^{*1} , COM3 ^{*2} , COM4	COM3 ^{*2}	COM3 ^{*2}
PS-3711A	COM1 ^{*1} , COM2 ^{*2}	COM2 ^{*2}	COM2 ^{*2}
PL-3000B, PL-3600T, PL-3600K, PL-3700T, PL-3700K, PL-3900T	COM1 ^{*1*2} , COM2 ^{*1} , COM3, COM4	COM1 ^{*1*2}	COM1 ^{*1*2}

*1 The RI/5V can be switched. Use the IPC's switch to change if necessary.

*2 Set up the SIO type with the DIP switch. Please set up as follows according to SIO type to be used.

DIP switch setting: RS-232C

DIP switch	Setting	Description
1	OFF ^{*1}	Reserved (always OFF)
2	OFF	SIO type: RS-232C
3	OFF	
4	OFF	Output mode of SD (TXD) data: Always output
5	OFF	Terminal resistance (220Ω) insertion to SD (TXD): None
6	OFF	Terminal resistance (220Ω) insertion to RD (RXD): None
7	OFF	Short-circuit of SDA (TXA) and RDA (RXA): Not available
8	OFF	Short-circuit of SDB (TXB) and RDB (RXB): Not available
9	OFF	RS (RTS) Auto control mode: Disabled
10	OFF	

*1 When using PS-3450A, PS-3451A, PS3000-BA and PS3001-BD, turn ON the set value.

Dip switch setting: RS-422/485 (4 wire)

Dip switch	Setting	Description
1	OFF	Reserve (always OFF)
2	ON	SIO type: RS-422/485
3	ON	
4	OFF	Output mode of SD (TXD) data: Always output
5	OFF	Terminal resistance (220Ω) insertion to SD (TXD): None
6	OFF	Terminal resistance (220Ω) insertion to RD (RXD): None
7	OFF	Short-circuit of SDA (TXA) and RDA (RXA): Does not Exist
8	OFF	Short-circuit of SDB (TXB) and RDB (RXB): Does not Exist
9	OFF ^{*1}	RS (RTS) Auto control mode: Disable
10	OFF ^{*1}	

*1 When the connection configuration is a n:1 connection, turn ON the set value.

Dip switch setting: RS-422/485 (2 wire)

Dip switch	Setting	Description
1	OFF	Reserve (always OFF)
2	ON	SIO type: RS-422/485
3	ON	
4	OFF	Output mode of SD (TXD) data: Always output
5	OFF	Terminal resistance (220Ω) insertion to SD (TXD): None
6	OFF	Terminal resistance (220Ω) insertion to RD (RXD): None
7	ON	Short-circuit of SDA (TXA) and RDA (RXA): Exist
8	ON	Short-circuit of SDB (TXB) and RDB (RXB): Exist
9	ON	RS (RTS) Auto control mode: Enable
10	ON	

2 Selection of External Device

Select the External Device to be connected to the Display.

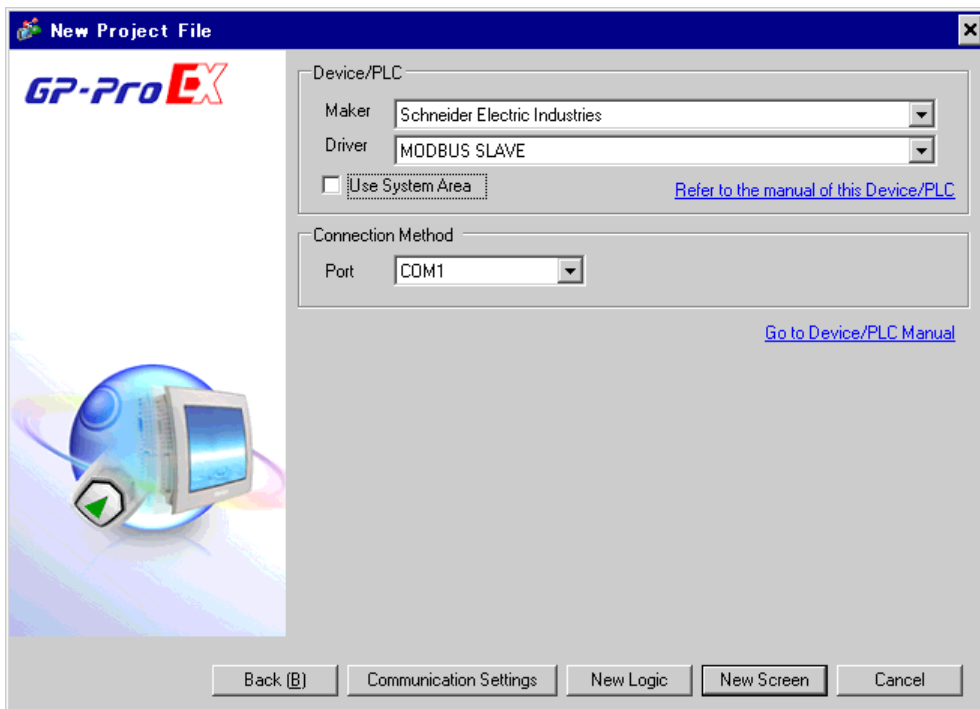

Setup Items	Setup Description
Maker	Select the maker of the External Device to be connected. Select "Schneider Electric Industries".
Driver	Select a model (series) of the External Device to be connected and connection method. Select "MODBUS SLAVE". Check the External Device which can be connected in "MODBUS SLAVE" in system configuration. ☞ "1 System Configuration" (page 3)
Use System Area	Check this option when you synchronize the system data area of the Display and the device (memory) of the External Device. When synchronized, you can use the ladder program of the External Device to switch the display or display the window on the Display. Cf. GP-Pro EX Reference Manual "Appendix 1.4 LS Area (Direct Access Method)" This can be also set with GP-Pro EX or in off-line mode of the Display. Cf. GP-Pro EX Reference Manual "5.17.6 Setting Guide of [System Setting Window] ■ Setting Guide of [Main Unit Settings] ■ System Area Setting" Cf. Maintenance/Troubleshooting "2.15.1 Settings common to all Display models ◆ System Area Settings"
Port	Select the Display port to be connected to the External Device.

3 Example of Communication Setting

Examples of communication settings of the Display and the External Device, recommended by Digital Electronics Corp., are shown.

3.1 Setting Example 1

■ Setting of GP-Pro EX

◆ Communication Settings

To display the setting screen, select [Device/PLC Settings] from [System setting window] in workspace.

Device/PLC 1

Summary [Change Device/PLC](#)

Maker Driver Port

Text Data Mode [Change](#)

Communication Settings

SIO Type RS232C RS422/485(2wire) RS422/485(4wire)

Speed

Data Length 7 8

Parity NONE EVEN ODD

Stop Bit 1 2

Flow Control NONE ER(DTR/CTS) XON/XOFF

Wait To Send (ms) Default Value

Equipment Address

Slave Equipment Address

RI / VCC RI VCC

In the case of RS232C, you can select the 9th pin to RI (Input) or VCC (5V Power Supply). If you use the Digital's RS232C Isolation Unit, please select it to VCC.

Device-Specific Settings

Allowable No. of Device/PLCs Unit(s)

No.	Device Name	Settings
<input type="text" value="1"/>	<input type="text" value="PLC1"/>	<input type="text" value="IEC61131 Syntax=OFF, Double Word word order=Low word first(L/H)"/>

◆ Device Setting

To display the setting screen, click  ([Setting]) of the External Device you want to set from [Device-Specific Settings] of [Device/PLC Settings].

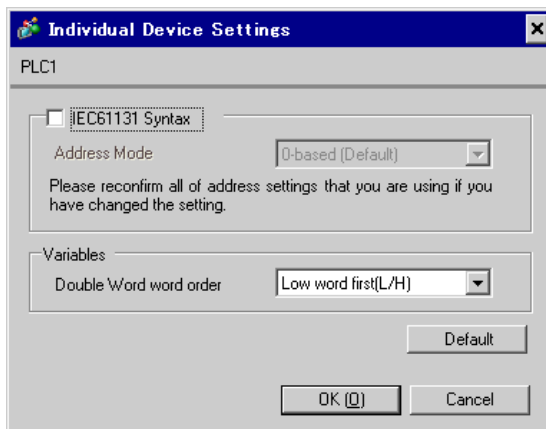

■ Settings of External Device

The communication settings depend on the External Device (Master) to be used. Please refer to the manual of the External Device for more details.

◆ Procedure

1. Set the communication settings of the External Device (Master) as follows.

Setup Items	Setup Description
Transmission Speed	19200
Data Length	8
With/Without Parity	ON
Parity Bit	EVEN
Stop Bit	1
Flow Control	NONE
Wait To Send	3 or more
Address Mode	Modicon

NOTE • Keep a gap of 3.5 characters or more between packets.

3.2 Setting Example 2

■ Setting of GP-Pro EX

◆ Communication Settings

To display the setting screen, select [Device/PLC Settings] from [System setting window] in workspace.

Device/PLC 1

Summary [Change Device/PLC](#)

Maker Driver Port

Text Data Mode [Change](#)

Communication Settings

SIO Type RS232C RS422/485(2wire) RS422/485(4wire)

Speed

Data Length 7 8

Parity NONE EVEN ODD

Stop Bit 1 2

Flow Control NONE ER(DTR/GTS) XON/XOFF

Wait To Send (ms) Default Value

Equipment Address

Slave Equipment Address

RI / VCC RI VCC

In the case of RS232C, you can select the 9th pin to RI (Input) or VCC (5V Power Supply). If you use the Digital's RS232C Isolation Unit, please select it to VCC.

Device-Specific Settings

Allowable No. of Device/PLCs Unit(s)

No.	Device Name	Settings
<input type="button" value="1"/>	<input type="text" value="PLC1"/>	<input type="button" value="IEC61131 Syntax=OFF,Double Word word order=Low word first(L/H)"/>

◆ Device Setting

To display the setting screen, click  ([Setting]) of the External Device you want to set from [Device-Specific Settings] of [Device/PLC Settings].

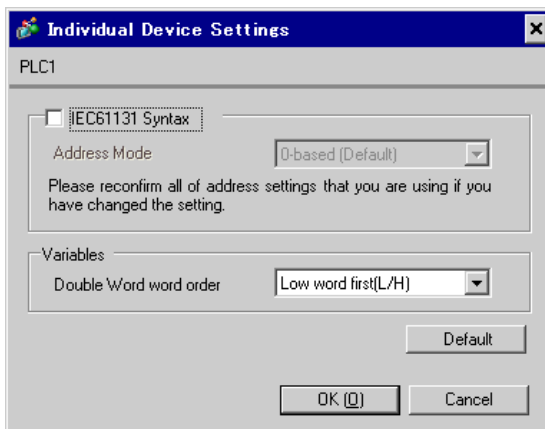

■ Settings of External Device

The communication settings depend on the External Device (Master) to be used. Please refer to the manual of the External Device for more details.

◆ Procedure

1. Set the communication settings of the External Device (Master) as follows.

Setup Items	Setup Description
Transmission Speed	19200
Data Length	8
With/Without Parity	ON
Parity Bit	EVEN
Stop Bit	1
Flow Control	NONE
Wait To Send	3 or more
Address Mode	Modicon

NOTE • Keep a gap of 3.5 characters or more between packets.

3.3 Setting Example 3

■ Setting of GP-Pro EX

◆ Communication Settings

To display the setting screen, select [Device/PLC Settings] from [System setting window] in workspace.

Device/PLC 1

Summary [Change Device/PLC](#)

Maker Driver Port

Text Data Mode [Change](#)

Communication Settings

SIO Type RS232C RS422/485(2wire) RS422/485(4wire)

Speed

Data Length 7 8

Parity NONE EVEN ODD

Stop Bit 1 2

Flow Control NONE ER(DTR/GTS) XON/XOFF

Wait To Send (ms) Default Value

Equipment Address

Slave Equipment Address

RI / VCC RI VCC

In the case of RS232C, you can select the 9th pin to RI (Input) or VCC (5V Power Supply). If you use the Digital's RS232C Isolation Unit, please select it to VCC.

Device-Specific Settings

Allowable No. of Device/PLCs Unit(s)

No.	Device Name	Settings
<input type="text" value="1"/>	<input type="text" value="PLC1"/>	<input type="text" value="IEC61131 Syntax=OFF,Double Word word order=Low word first(L/H)"/>

◆ Device Setting

To display the setting screen, click  ([Setting]) of the External Device you want to set from [Device-Specific Settings] of [Device/PLC Settings].

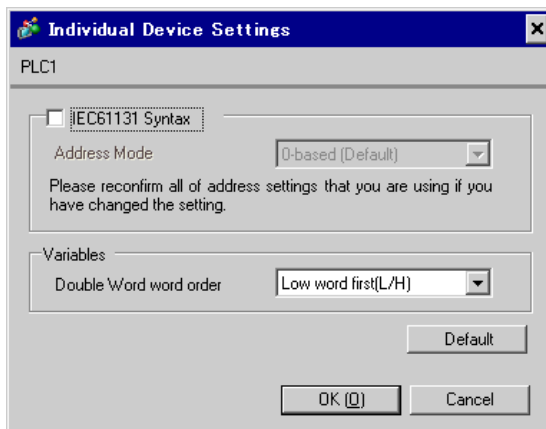

■ Settings of External Device

The communication settings depend on the External Device (Master) to be used. Please refer to the manual of the External Device for more details.

◆ Procedure

1. Set the communication settings of the External Device (Master) as follows.

Setup Items	Setup Description
Transmission Speed	19200
Data Length	8
With/Without Parity	ON
Parity Bit	EVEN
Stop Bit	1
Flow Control	NONE
Wait To Send	3 or more
Address Mode	Modicon

NOTE • Keep a gap of 3.5 characters or more between packets.

3.4 Setting Example 4

■ Setting of GP-Pro EX

◆ Communication Settings

To display the setting screen, select [Device/PLC Settings] from [System setting window] in workspace.

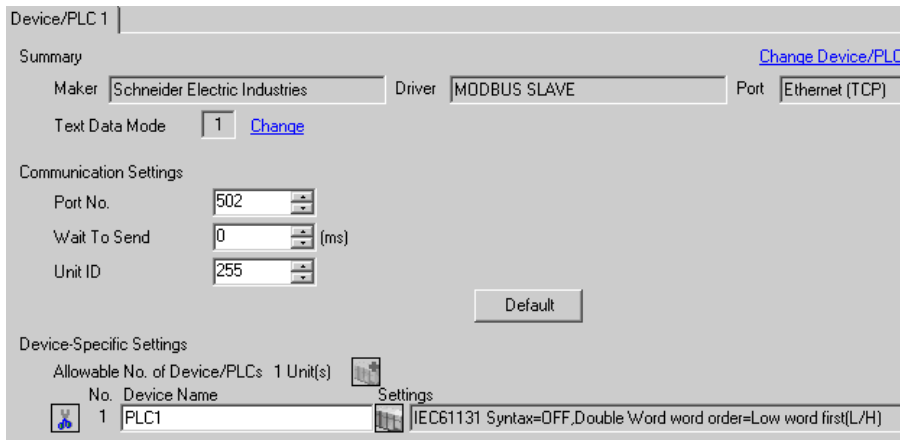

◆ Device Setting

To display the setting screen, click ([Setting]) of the External Device you want to set from [Device-Specific Settings] of [Device/PLC Settings].

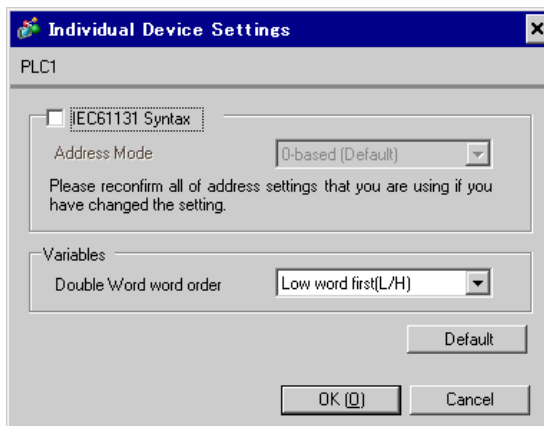

■ Settings of External Device

The communication settings depend on the External Device (Master) to be used. Please refer to the manual of the External Device for more details.

◆ Procedure

1. Set the communication settings of the External Device (Master) as follows.

Setup Items	Setup Description
Wait To Send	0
Source port number	Any number
Destination port number	502
Address Mode	Modicon

4 Setup Items

Set communication settings of the Display with GP-Pro Ex or in off-line mode of the Display.

The setting of each parameter must be identical to that of External Device.

☞ "3 Example of Communication Setting" (page 10)

NOTE • Set the Display's IP address in off-line mode.

Cf. Maintenance/Troubleshooting Manual "2.5 Ethernet Settings"

4.1 Serial Connection

■ Setup Items in GP-Pro EX

◆ Communication Settings

To display the setting screen, select [Device/PLC Settings] from [System setting window] in workspace.

The screenshot shows the 'Device/PLC 1' settings window. It is divided into several sections:

- Summary:** Includes fields for 'Maker' (Schneider Electric Industries), 'Driver' (MODBUS SLAVE), and 'Port' (COM1). There is a 'Change Device/PLC' link.
- Text Data Mode:** Set to '1' with a 'Change' link.
- Communication Settings:**
 - SIO Type:** Radio buttons for RS232C (selected), RS422/485(2wire), and RS422/485(4wire).
 - Speed:** A dropdown menu set to 19200.
 - Data Length:** Radio buttons for 7 and 8 (selected).
 - Parity:** Radio buttons for NONE, EVEN (selected), and ODD.
 - Stop Bit:** Radio buttons for 1 (selected) and 2.
 - Flow Control:** Radio buttons for NONE (selected), ER(DTR/GTS), and XON/XOFF.
- Wait To Send:** A numeric field set to 3 (ms) with a 'Default Value' checkbox checked.
- Equipment Address:** A field for 'Slave Equipment Address' set to 1.
- RI / VCC:** Radio buttons for RI (selected) and VCC. A note below explains the selection criteria for RS232C.
- Default:** A button to reset settings.
- Device-Specific Settings:**
 - Allowable No. of Device/PLCs:** 1 Unit(s).
 - No.:** 1
 - Device Name:** PLC1
 - Settings:** IEC61131 Syntax=OFF, Double Word word order=Low word first(L/H)

Setup Items	Setup Description
SIO Type	Select the SIO type to communicate with the External Device.
Speed	Select speed between the External Device and the Display.
Data Length	Select data length.
Parity	Select how to check parity.
Stop Bit	Select stop bit length.

Setup Items	Setup Description
Flow Control	Display the communication control method to prevent overflow of transmission and reception data.
Wait To Send	<p>Use an integer from "1 to 255" to enter standby time (ms) for the Display from receiving packets to transmitting next commands.</p> <p>When the check box of the default value is checked, the Wait To Send value automatically changes in the formula below by changing each value for Speed/Data Length/Parity/Stop Bit.</p> $\text{Wait To Send (ms)} = \frac{3500 \times (1 + \text{Data Length} + \text{Stop Bit} + \text{Parity})}{\text{Speed (bps)}}$ <p>Value for the parity setting is shown below. No Parity = 0 Parity Even = 1 Parity Odd = 1</p>
Slave Equipment Address	Use an integer from "1 to 247" to enter the slave address of the External Device.
RI/VCC	<p>You can switch RI/VCC of the 9th pin when you select RS232C for SIO type.</p> <p>It is necessary to change RI/5V by changeover switch of IPC when connect with IPC. Please refer to the manual of the IPC for more detail.</p>

◆ Device Setting

To display the setting screen, click ([Setting]) of the External Device you want to set from [Device-Specific Settings] of [Device/PLC Settings].

When you connect multiple External Device, click from [Device-Specific Settings] of [Device/PLC Settings] to add the External Device which is available to set.

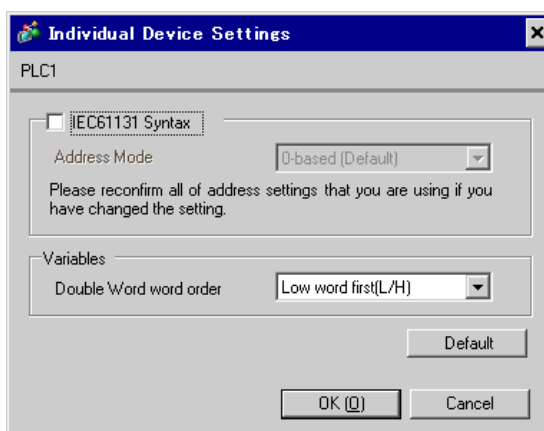

Setup Items	Setup Description
IEC61131 Syntax	Check this item when you use the IEC61131 grammar for variables.
Address Mode	If you check the IEC61131 Syntax check box, select the address mode from "0-based" or "1-based".
Double Word word order	Select the order of storing double word data from "Low word first" or "High word first".

■ Settings in Off-Line Mode

NOTE • Please refer to Maintenance/Troubleshooting for more information on how to enter off-line mode or about operation.

Cf. Maintenance/Troubleshooting "2.2 Offline Mode"

◆ Communication Settings

To display the setting screen, touch [Device/PLC Settings] from [Peripheral Equipment Settings] in the off-line mode. Touch the External Device you want to set from the displayed list.

Comm.	Device	Option		
MODBUS SLAVE		[COM1]	Page 1/1	
SIO Type	RS232C			
Speed	19200			
Data Length	<input type="radio"/> 7 <input checked="" type="radio"/> 8			
Parity	<input type="radio"/> NONE <input checked="" type="radio"/> EVEN <input type="radio"/> ODD			
Stop Bit	<input checked="" type="radio"/> 1 <input type="radio"/> 2			
Flow Control	NONE			
Wait To Send(ms)	3			
Slave Address	1			
Exit		Back		2006/10/19 09:18:19

Setup Items	Setup Description
SIO Type	Select the SIO type to communicate with the External Device. IMPORTANT To make the communication settings correctly, confirm the serial interface specifications of Display unit for [SIO Type]. We cannot guarantee the operation if a communication type that the serial interface does not support is specified. For details concerning the serial interface specifications, refer to the manual for Display unit.
Speed	Select speed between the External Device and the Display.
Data Length	Select data length.
Parity	Select how to check parity.
Stop Bit	Select stop bit length.
Flow Control	Display the communication control method to prevent overflow of transmission and reception data.

Setup Items	Setup Description
Wait To Send	<p>Use an integer from "1 to 255" to enter standby time (ms) for the Display from receiving packets to transmitting next commands. After changing the values of Speed/Data Length/Parity/Stop Bit, set the Wait To Send value using the following formula.</p> $\text{Wait To Send (ms)} = \frac{3500 \times (1 + \text{Data Length} + \text{Stop Bit} + \text{Parity})}{\text{Speed (bps)}}$ <p>Value for the parity setting is shown below. No Parity = 0 Parity Even = 1 Parity Odd = 1</p>
Slave Address	Use an integer from "1 to 247" to enter the slave address of the External Device.

◆ Device Setting

To display the setting screen, touch [Device/PLC Settings] from [Peripheral Equipment Settings]. Touch the External Device you want to set from the displayed list, and touch [Device Settings].

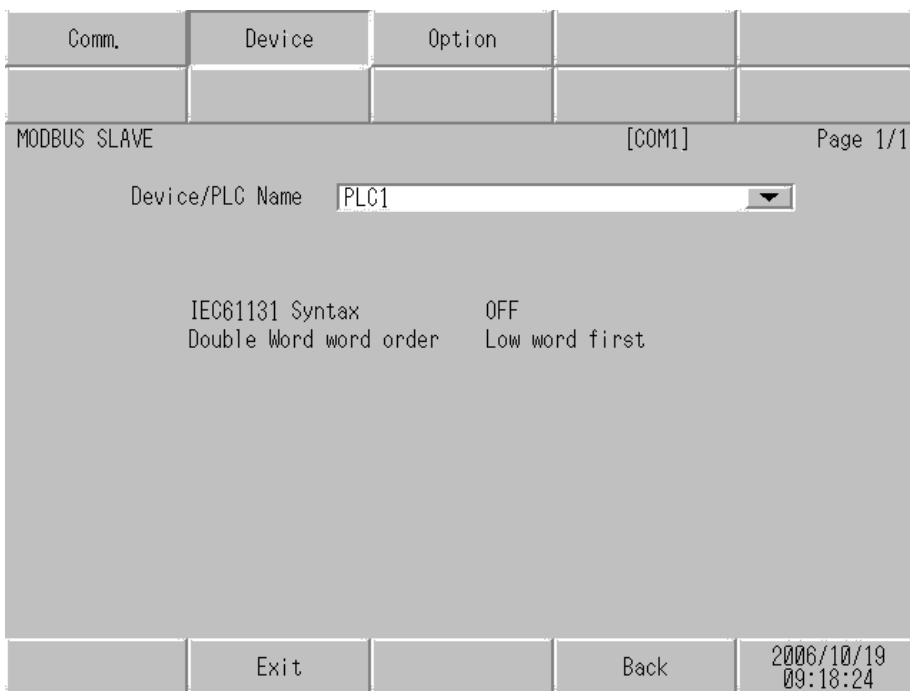

Setup Items	Setup Description
Device/PLC name	Select the External Device to set. Device name is a title of the External Device set with GP-Pro EX. (Initial value [PLC])
IEC61131 Syntax	Displays whether IEC61131 syntax is used or not.
DWord Word Order	Displays the order in which double word data is stored.

◆ Option

To display the setting screen, touch [Device/PLC Settings] from [Peripheral Equipment Settings]. Touch the External Device you want to set from the displayed list, and touch [Option].

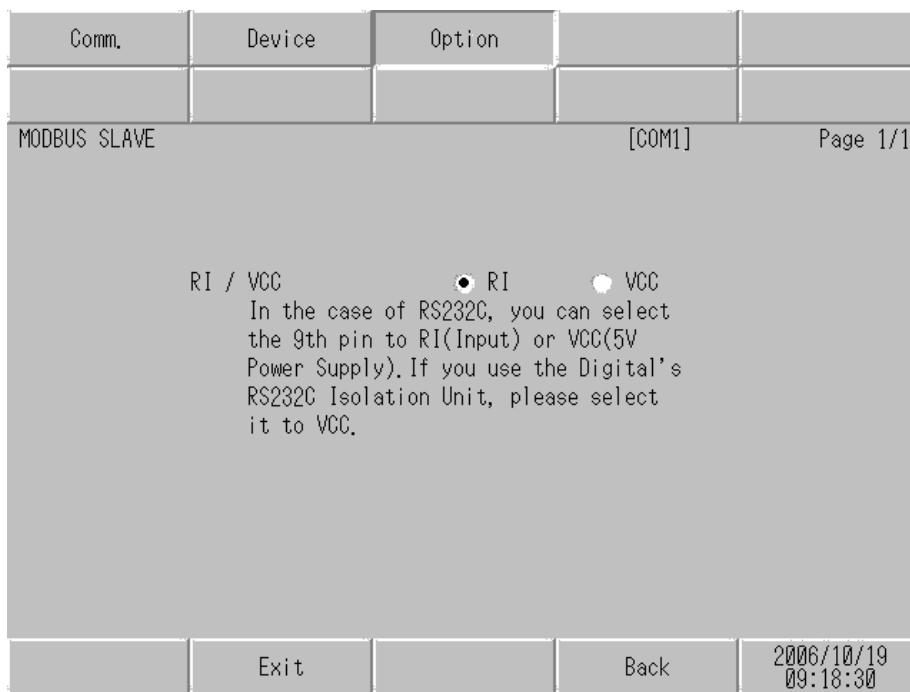

Setup Items	Setup Description
RI/VCC	Switches RI/VCC of the 9th pin. It is necessary to change RI/5V by changeover switch of IPC when connect with IPC. Please refer to the manual of the IPC for more detail.

4.2 Ethernet (TCP) Connection

■ Setup Items in GP-Pro EX

◆ Communication Settings

To display the setting screen, select [Device/PLC Settings] from [System setting window] in workspace.

Device/PLC 1

Summary [Change Device/PLC](#)

Maker Schneider Electric Industries Driver MODBUS SLAVE Port Ethernet (TCP)

Text Data Mode 1 [Change](#)

Communication Settings

Port No. 502

Wait To Send 0 (ms)

Unit ID 255

Default

Device-Specific Settings

Allowable No. of Device/PLCs 1 Unit(s)

No.	Device Name	Settings
1	PLC1	IEC61131 Syntax=OFF,Double Word word order=Low word first(L/H)

Setup Items	Setup Description
Port No.	Use an integer "502" or from "1024 to 65535" to enter the port No. of the Display.
Wait To Send	Use an integer from "0 to 255" to enter standby time (ms) for the Display from receiving packets to transmitting next commands.
Unit ID	Use an integer from "1 to 247" or "255" to enter the slave address.

◆ Device Setting

To display the setting screen, click  ([Setting]) of the External Device you want to set from [Device-Specific Settings] of [Device/PLC Settings].

When you connect multiple External Device, click  from [Device-Specific Settings] of [Device/PLC Settings] to add the External Device which is available to set.

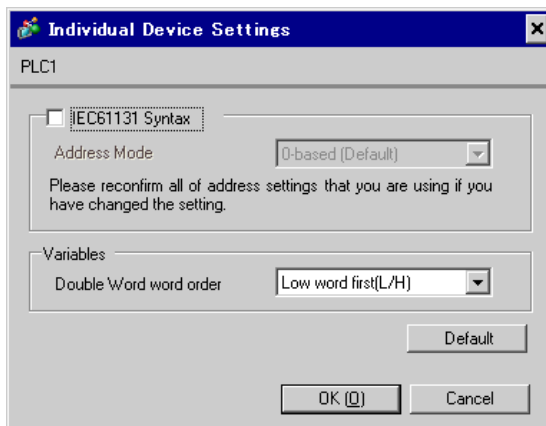

Setup Items	Setup Description
IEC61131 Syntax	Check this item when you use the IEC61131 grammar for variables.
Address Mode	If you check the IEC61131 Syntax check box, select the address mode from "0-based" or "1-based".
Double Word word order	Select the order of storing double word data from "Low word first" or "High word first".

■ Settings in Off-Line Mode

NOTE • Please refer to Maintenance/Troubleshooting for more information on how to enter off-line mode or about operation.

Cf. Maintenance/Troubleshooting "2.2 Offline Mode"

◆ Communication Settings

To display the setting screen, touch [Device/PLC Settings] from [Peripheral Equipment Settings] in the off-line mode. Touch the External Device you want to set from the displayed list.

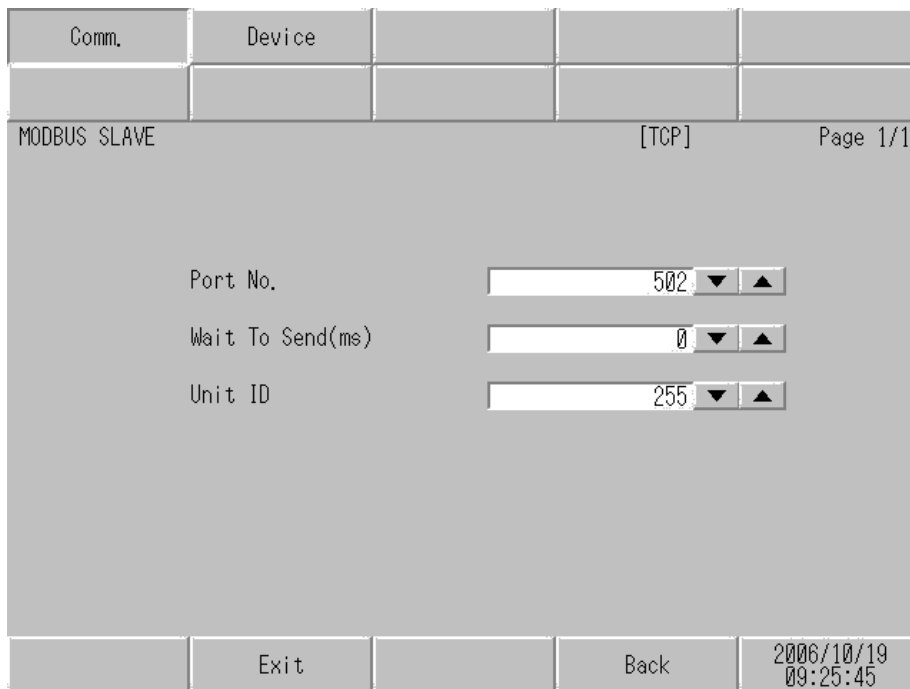

Setup Items	Setup Description
Port No.	Use an integer "502" or from "1024 to 65535" to enter the port No. of the Display.
Wait To Send	Use an integer from "0 to 255" to enter standby time (ms) for the Display from receiving packets to transmitting next commands.
Unit ID	Use an integer from "1 to 247" or "255" to enter the slave address.

◆ Device Setting

To display the setting screen, touch [Device/PLC Settings] from [Peripheral Equipment Settings]. Touch the External Device you want to set from the displayed list, and touch [Device Settings].

Comm.	Device			
MODBUS SLAVE		[TCP]	Page 1/1	
Device/PLC Name		PLC1		
IEC61131 Syntax		OFF		
Double Word word order		Low word first		
Exit		Back		2006/10/19 09:25:48

Setup Items	Setup Description
Device/PLC name	Select the External Device to set. Device name is a title of the External Device set with GP-Pro EX. (Initial value [PLC])
IEC61131 Syntax	Displays whether IEC61131 syntax is used or not.
DWord Word Order	Displays the order in which double word data is stored.

5 Cable Diagram

The cable diagram shown below may be different from the cable diagram recommended by Schneider Electric Industries. Please be assured there is no operational problem in applying the cable diagram shown in this manual.

- The FG pin of the main body of the External Device must be D-class grounded. Please refer to the manual of the External Device for more details.
- SG and FG are connected inside the Display. When connecting SG to the External Device, design the system not to form short-circuit loop.
- Connect the isolation unit, when communication is not stabilized under the influence of a noise etc..

Cable Diagram 1

Display (Connection Port)	Cable		Remarks
GP ^{*1} (COM1) AGP-3302B (COM2) ST ^{*2} (COM2)	A	COM port conversion adapter by Pro-face CA3-ADPCOM-01 + Terminal block conversion adapter by Pro-face CA3-ADPTRM-01 + Your own cable	Cable length: 1,000m or less (Depends on master's capacity)
	B	Your own cable	
GP ^{*3} (COM2)	C	Online adapter by Pro-face CA4-ADPONL-01 + Terminal block conversion adapter by Pro-face CA3-ADPTRM-01 + Your own cable	
	D	Online adapter by Pro-face CA4-ADPONL-01 + Your own cable	
IPC ^{*4}	F	COM port conversion adapter by Pro-face CA3-ADPCOM-01 + Terminal block conversion adapter by Pro-face CA3-ADPTRM-01 + Your own cable	
	F	Your own cable	

*1 All GP models except AGP-3302B

*2 All ST models except AST-3211A

*3 All GP models except GP-3200 series and AGP-3302B

*4 Only the COM port which can communicate by RS-422/485 (2 wire) can be used.
 " ■ IPC COM Port" (page 7)

A. When using the COM port conversion adapter (CA3-ADPCOM-01), the terminal block conversion adapter (CA3-ADPTRM-01) by Pro-face and your own cable

- 1:1 Connection

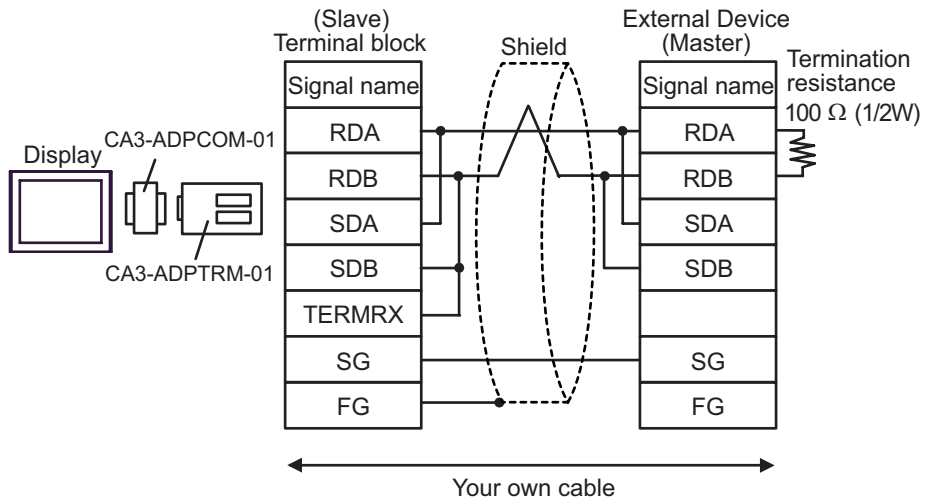

- n:1 Connection

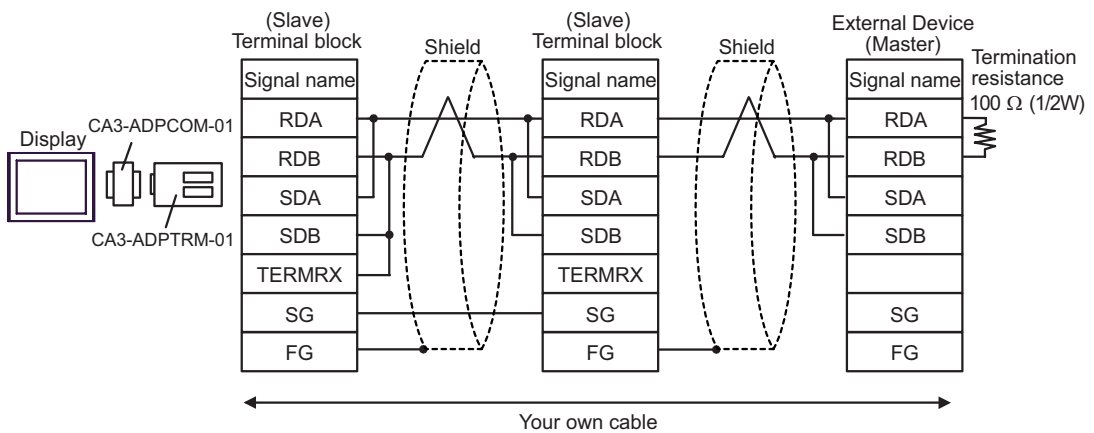

B. When your own cable is used

- 1:1 Connection

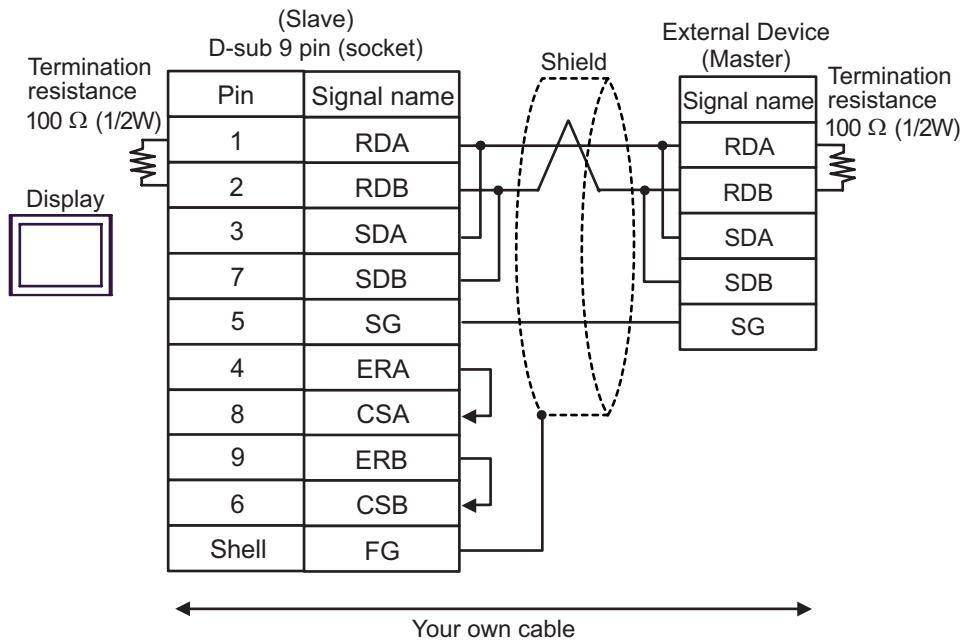

- n:1 Connection

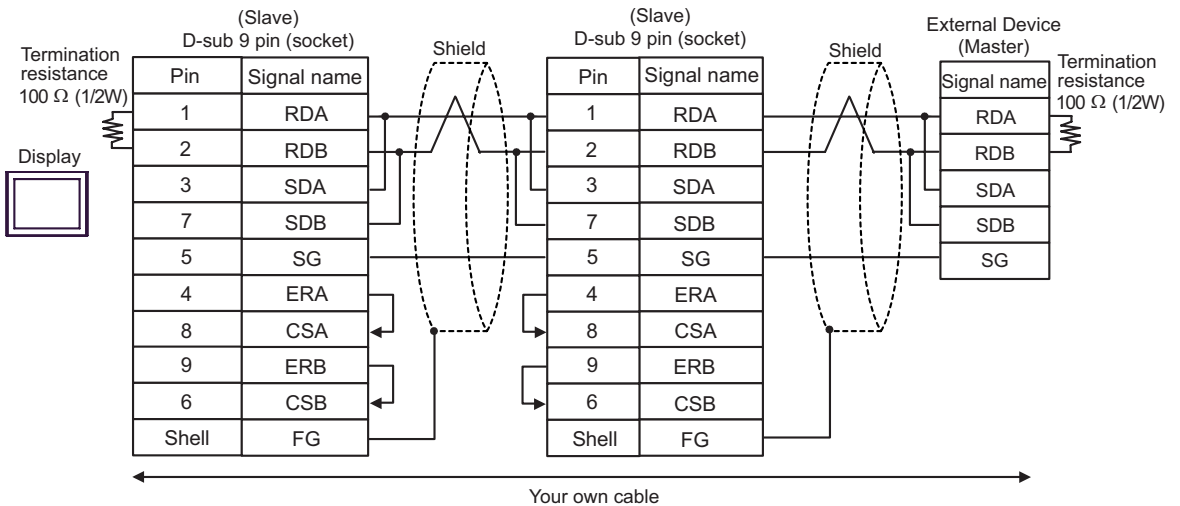

C. When using the online adapter (CA4-ADPONL-01), the terminal block conversion adapter (CA3-ADPTRM-01) by Pro-face and your own cable

- 1:1 Connection

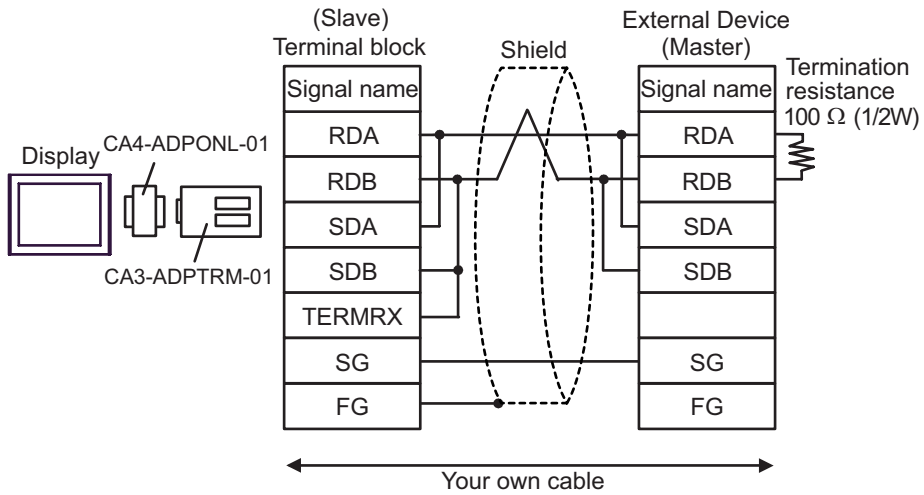

- n:1 Connection

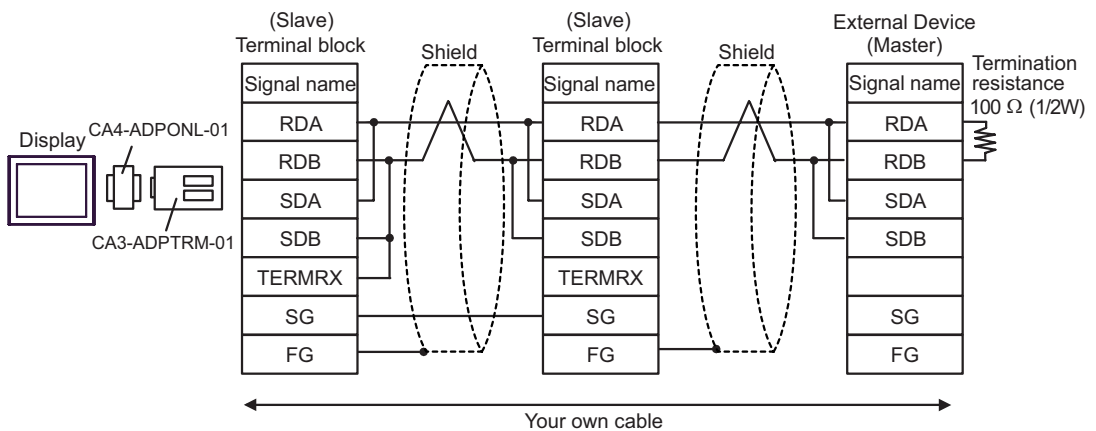

D. When using the online adapter (CA4-ADPONL-01) by Pro-face and your own cable

- 1:1 Connection

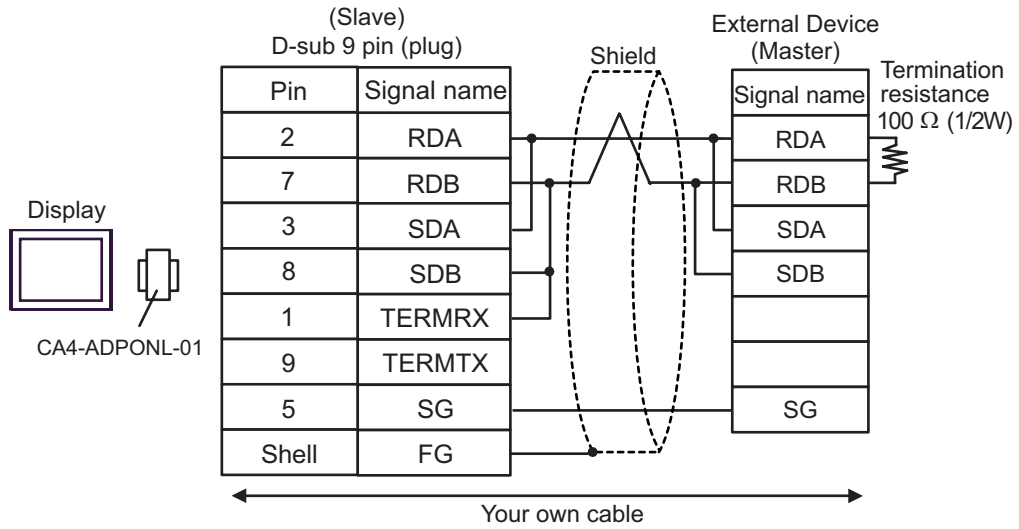

- n:1 Connection

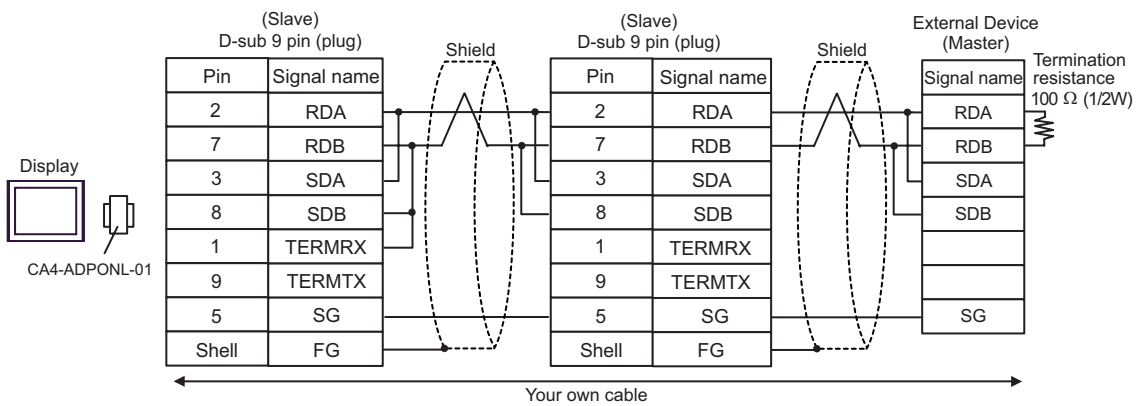

E. When using the COM port conversion adapter (CA3-ADPCOM-01), the terminal block conversion adapter (CA3-ADPTRM-01) by Pro-face and your own cable

- 1:1 Connection

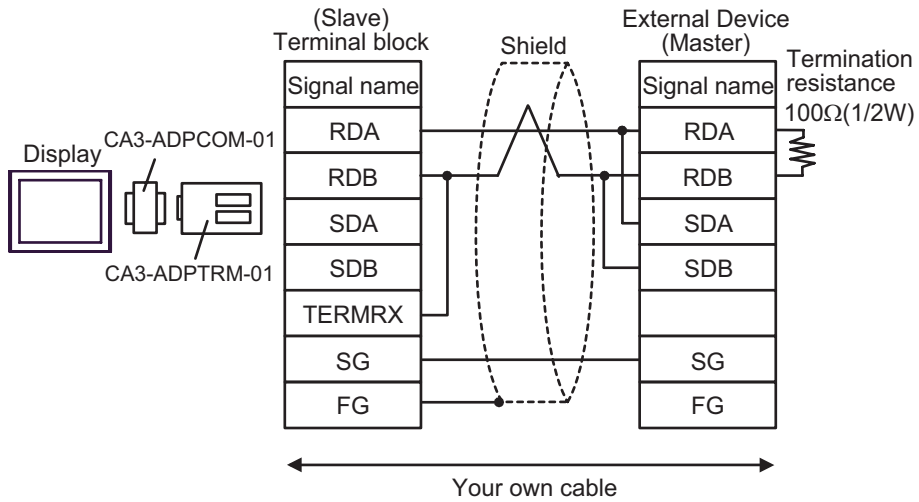

- n:1 Connection

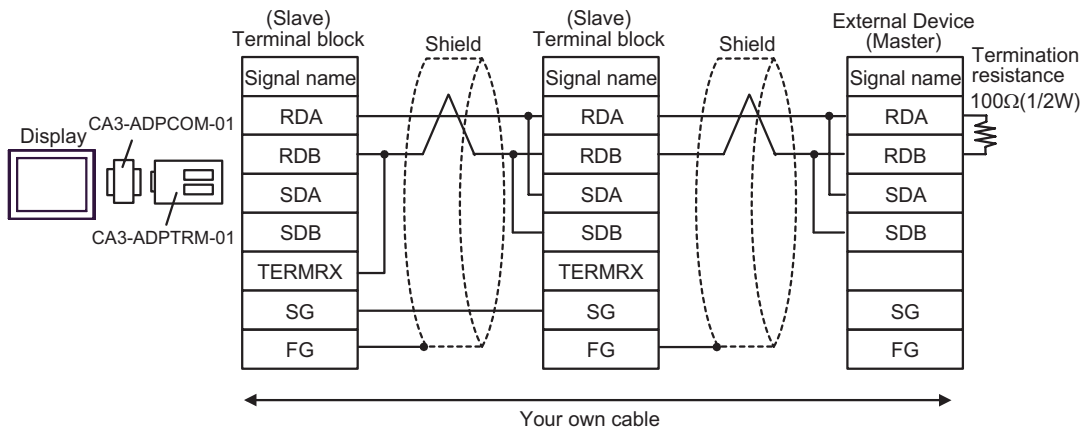

F. When your own cable is used

- 1:1 Connection

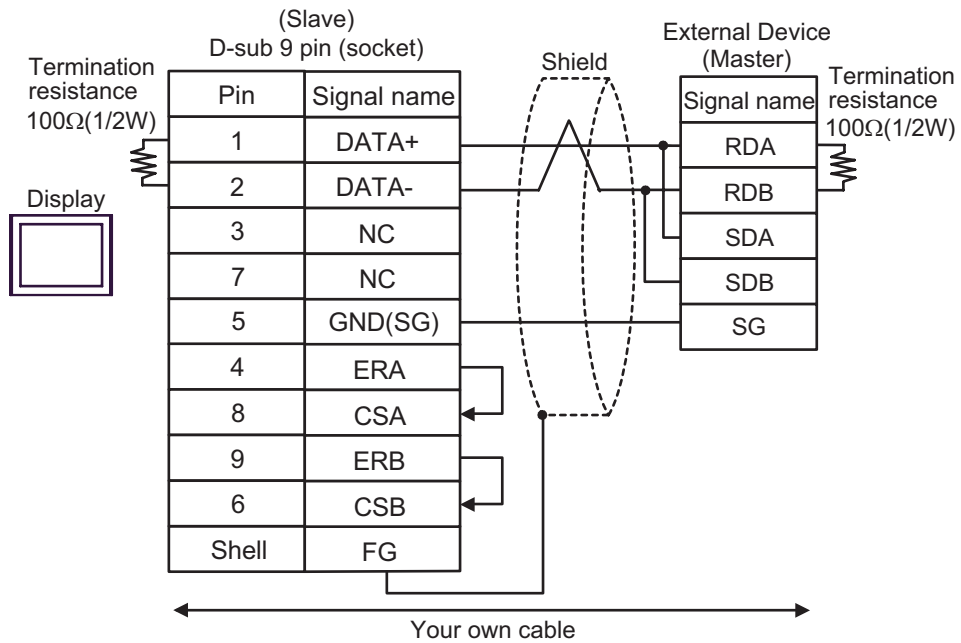

- n:1 Connection

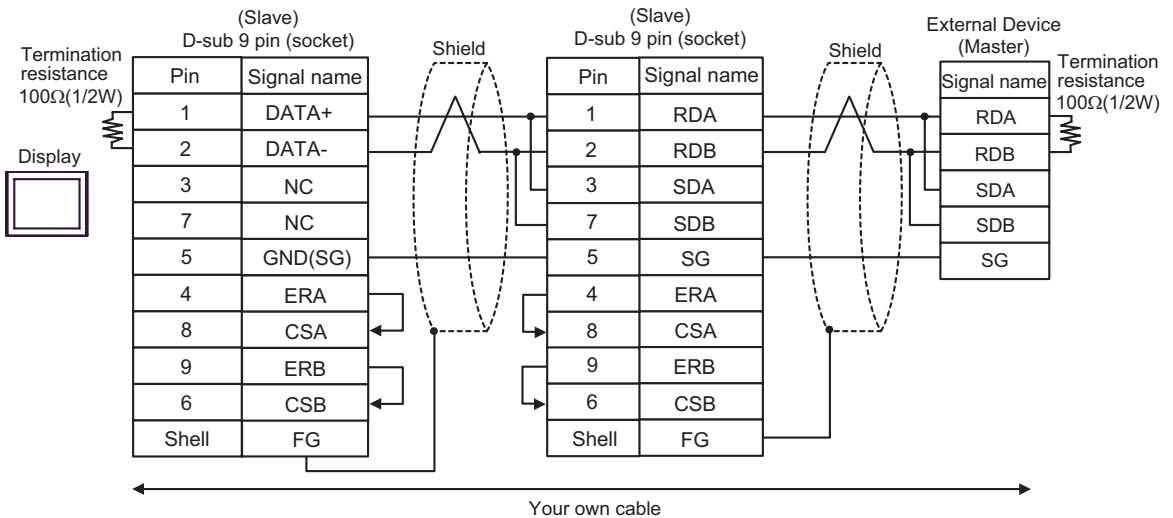

Cable Diagram 2

Display (Connection Port)	Cable		Remarks
GP (COM1) ST (COM1) IPC*1 PC/AT	A	Your own cable	Cable length: 15m or less
	B	Your own cable	

*1 Only the COM port which can communicate by RS-232C can be used.
 ☞ " ■ IPC COM Port" (page 7)

A. When using your own cable (flow control: none)

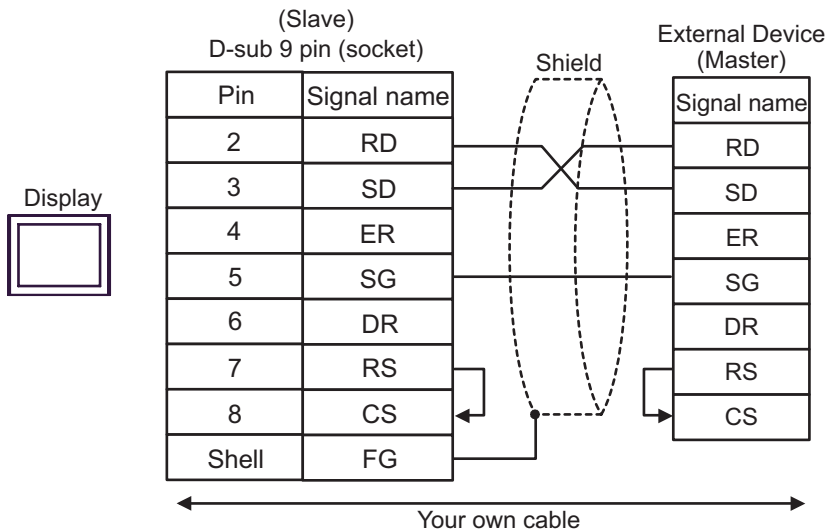

B. When using your own cable (flow control: DTR/CTS)

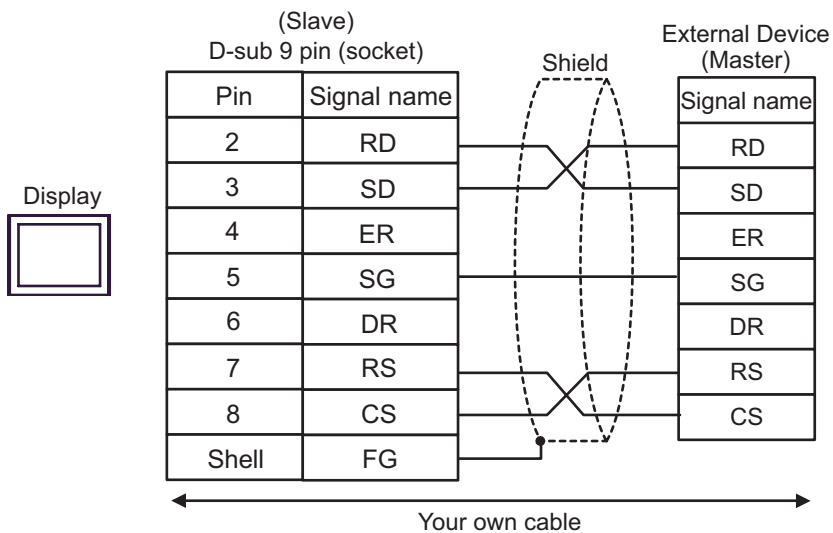

Cable Diagram 3

Display (Connection Port)	Cable		Remarks
GP* ¹ (COM1) AGP-3302B (COM2) ST* ² (COM2) IPC* ³	A	COM port conversion adapter by Pro-face CA3-ADPCOM-01 + Terminal block conversion adapter by Pro-face CA3-ADPTRM-01 + Your own cable	Cable length: 1,000m or less (Depends on master's capacity)
	B	Your own cable	
GP* ⁴ (COM2)	C	Online adapter by Pro-face CA4-ADPONL-01 + Terminal block conversion adapter by Pro-face CA3-ADPTRM-01 + Your own cable	
	D	Online adapter by Pro-face CA4-ADPONL-01 + Your own cable	

*1 All GP models except AGP-3302B

*2 All ST models except AST-3211A

*3 Only the COM port which can communicate by RS-422/485 (4 wire) can be used.
 " ■ IPC COM Port" (page 7)

*4 All GP models except GP-3200 series and AGP-3302B

A. When using the COM port conversion adapter (CA3-ADPCOM-01), the terminal block conversion adapter (CA3-ADPTRM-01) by Pro-face and your own cable

- 1:1 Connection

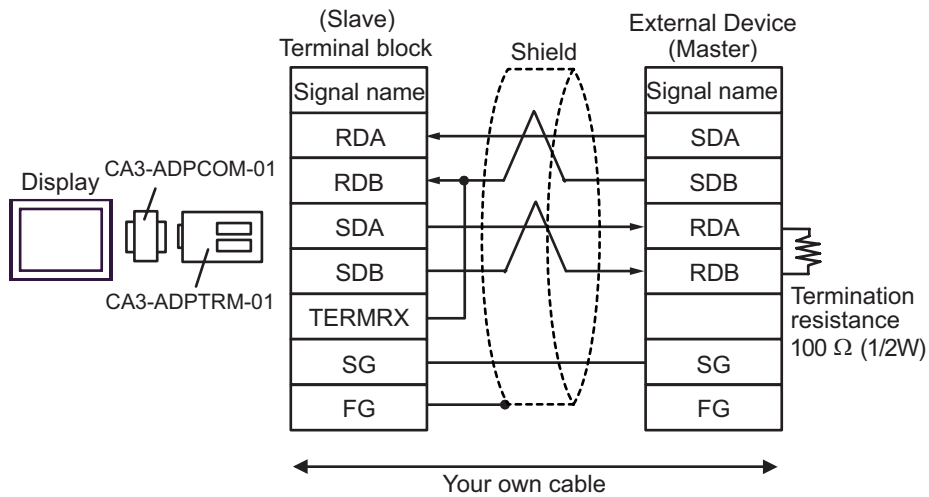

- n:1 Connection

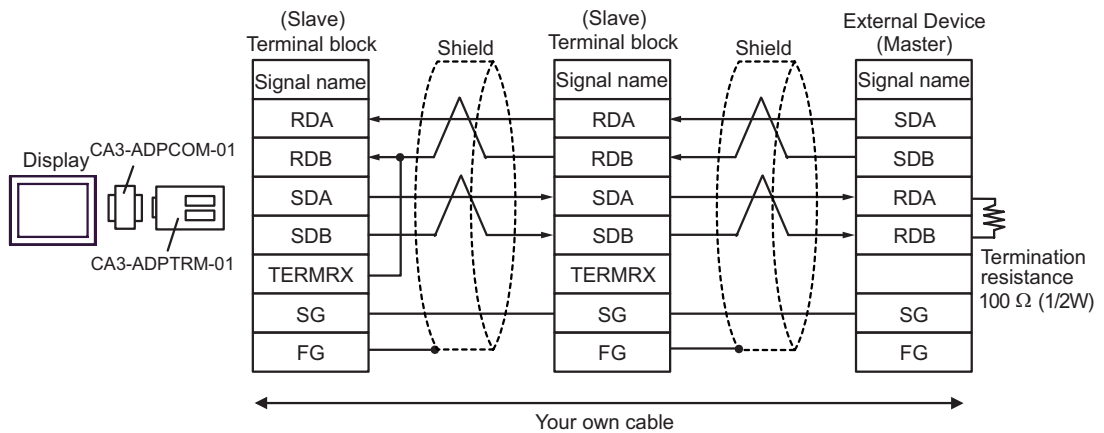

B. When your own cable is used

- 1:1 Connection

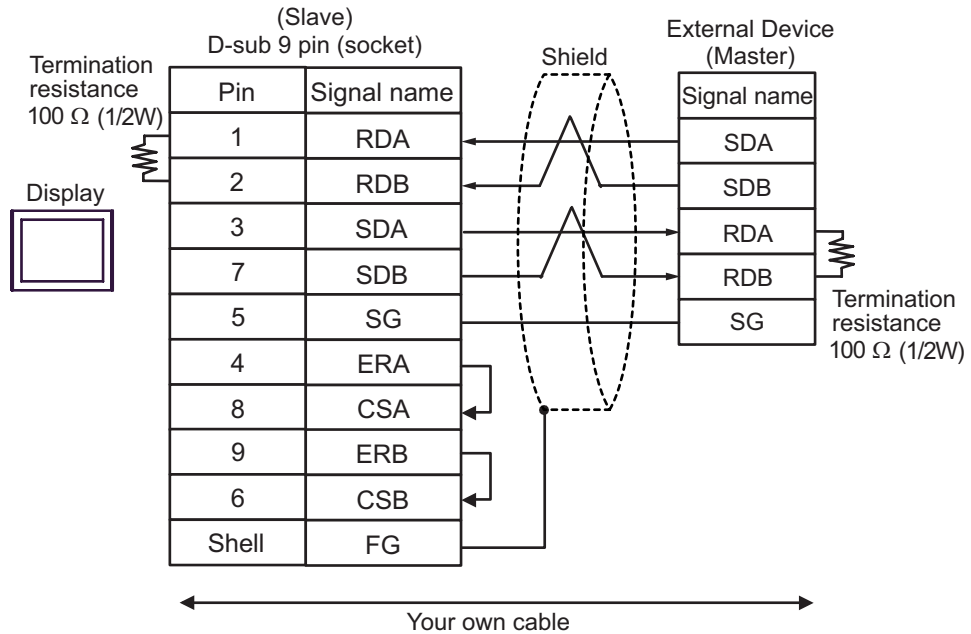

- n:1 Connection

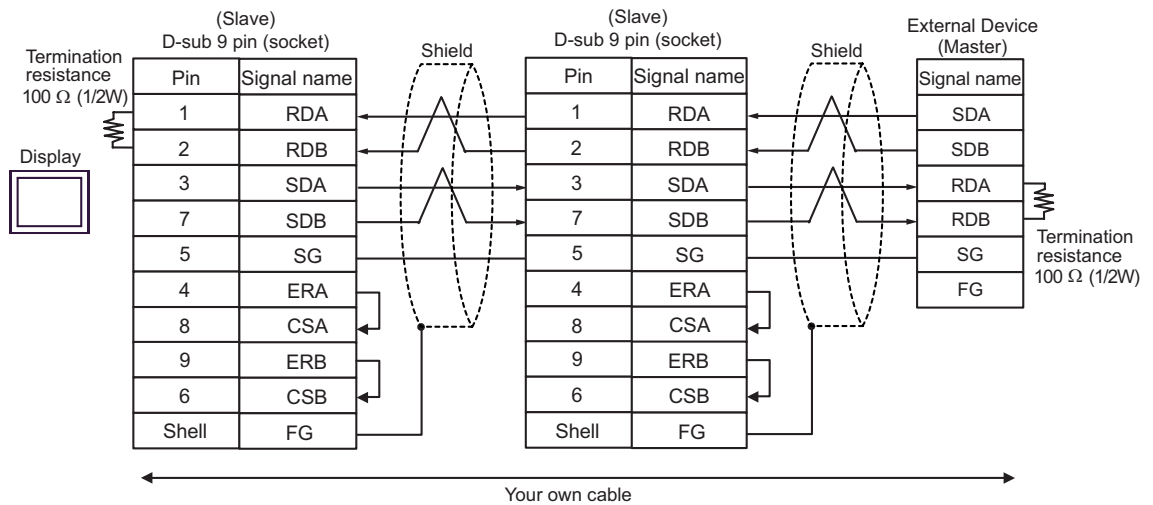

C. When using the online adapter (CA4-ADPONL-01), the terminal block conversion adapter (CA3-ADPTRM-01) by Pro-face and your own cable

- 1:1 Connection

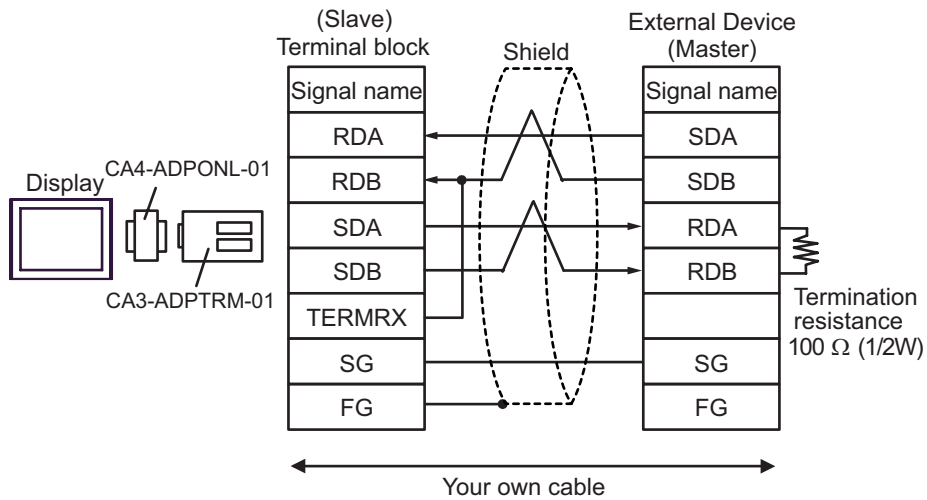

- n:1 Connection

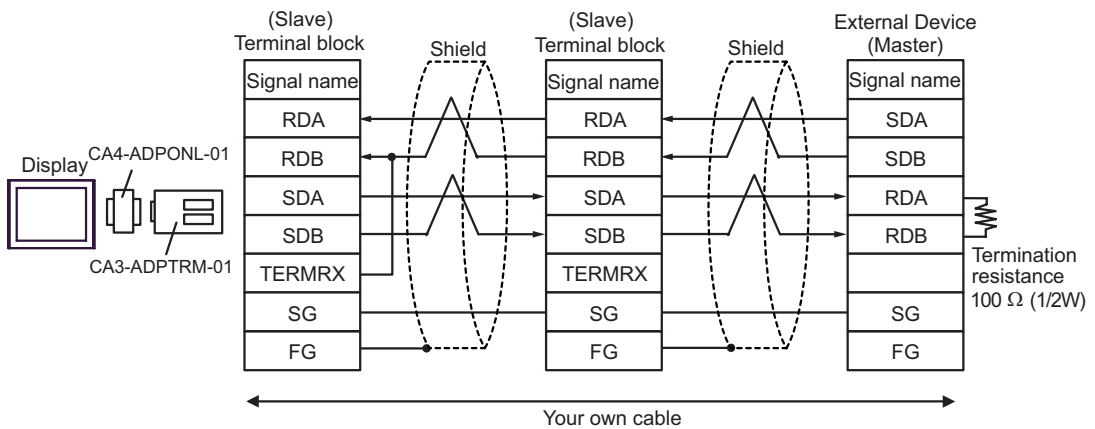

D. When using the online adapter (CA4-ADPONL-01) by Pro-face and your own cable

- 1:1 Connection

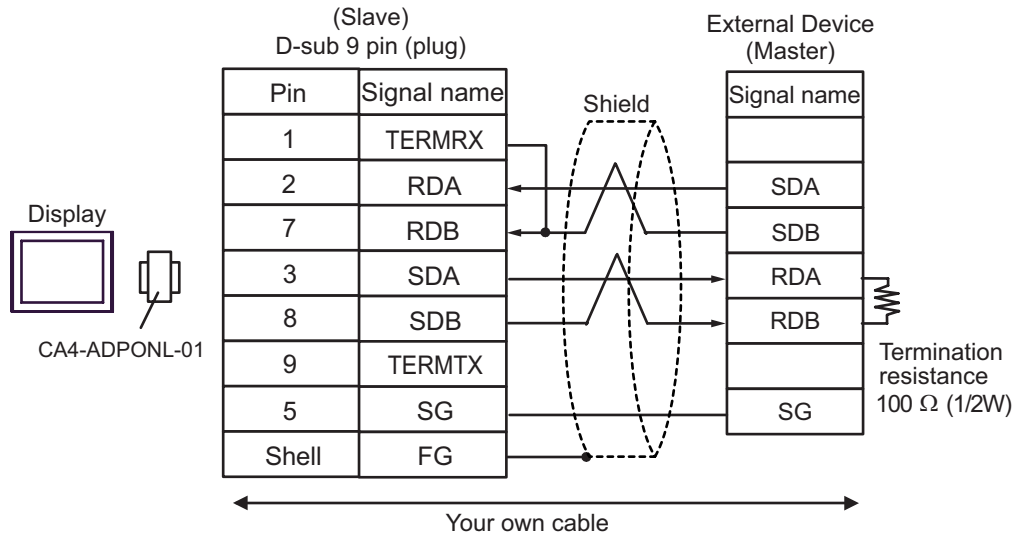



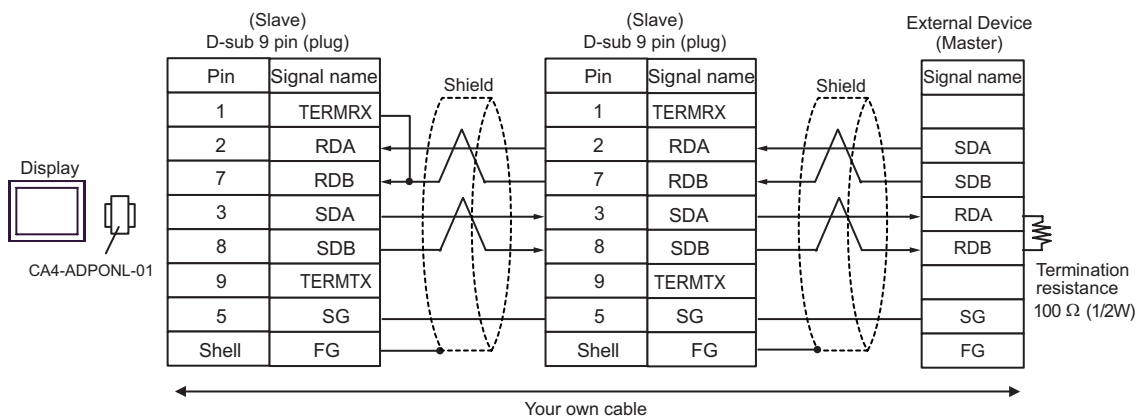

- n:1 Connection



6 Supported Device

Range of supported device address is shown in the table below. Please note that the actually supported range of the devices varies depending on the External Device to be used. Please check the actual range in the manual of your External Device.

 This address can be specified as system data area.

Device	Bit Address	Word Address	32 bits	Remarks
Coil	000001-008192	000001-008177	<div style="border: 1px solid black; padding: 2px; display: inline-block;">L/H</div> or <div style="border: 1px solid black; padding: 2px; display: inline-block;">H/L</div> *1	
Discrete Input	100001-108192	100001-108177		 *2
Input Register	300001,00-310000.15	300001-310000		 *2
Holding Register	400001,00-410000,15	400001-410000		

*1 You can set the data storing order in word unit of 32-bit data in the Device Setting dialog box.

*2 Write disable

IEC61131 Syntax Address Description

The following is a corresponding table for IEC61131 syntax and MODBUS syntax address descriptions.

Device	MODBUS Syntax			IEC61131 Syntax				
	Format	Range	First element	Format	0-based		1-based	
					Range	First element	Range	First element
Coil	000001+i	i = 0 to 8191	000001	%Mi	i = 0 to 8191	%M00000	i = 1 to 8192	%M00001
Discrete Input	100001+i	i = 0 to 8191	100001	-	-	-	-	-
Input Register (Word)	300001+i	i = 0 to 9999	300001	-	-	-	-	-
Input Register (Word bit)	300001+i, j	i = 0 to 9999 j = 0 to 15	300001,0 0	-	-	-	-	-
Holding Register (Word)	400001+i	i = 0 to 9999	400001	%MWi	i = 0 to 9999	%MW00000	i = 1 to 10000	%MW00001
Holding Register (Word bit)	400001+i, j	i = 0 to 9999 j = 0 to 15	400001,0 0	%MWi: Xj	i = 0 to 9999 j = 0 to 15	%MW00000 :X00	i = 1 to 10000 j = 0 to 15	%MW00001 :X00

NOTE

- The addresses 100000 and 300000 cannot be accessed using IEC61131 syntax.
- If you apply IEC61131 syntax to a project which has a discrete input or input register already set, the addresses become "-Undefined-".

NOTE

- Please refer to the GP-Pro EX Reference Manual for system data area.
Cf. GP-Pro EX Reference Manual "Appendix 1.4 LS Area (Direct Access Method)"
- Please refer to the precautions on manual notation for icons in the table.
 "Manual Symbols and Terminology"

7 Device Code and Address Code

Use device code and address code when you select "Device Type & Address" for the address type in data displays.

7.1 Modicon Syntax

Device	Device Name	Device Code (HEX)	Address Code
Coil	0	0080	(Word Address - 1) /16
Discrete Input	1	0081	(Word Address - 1) /16
Input Register	3	0001	Word Address - 1
Holding Register	4	0000	Word Address - 1

7.2 IEC61131 Syntax

- Address Mode: 0-based

Device	Device Name	Device Code (HEX)	Address Code
Coil	%M	0080	Word Address /16
Holding Register	%MW	0000	Word Address

- Address Mode: 1-based

Device	Device Name	Device Code (HEX)	Address Code
Coil	%M	0080	(Word Address - 1) /16
Holding Register	%MW	0000	Word Address - 1

8 Error Messages

Error messages are displayed on the screen of the Display as follows: "No. : Device Name: Error Message(Error Occurrence Area)". Each description is shown below.

Item	Description
No.	Error No.
Device Name	Name of the External Device where error occurs. Device name is a title of the External Device set with GP-Pro EX.((Initial value[PLC1])
Error Message	Displays messages related to the error which occurs.
Error Occurrence Area	<p>Displays IP address or device address of the External Device where error occurs, or error codes received from the External Device.</p> <p>NOTE</p> <ul style="list-style-type: none"> • IP address is displayed such as "IP address(Decimal): MAC address(Hex)". • Device address is displayed such as "Address: Device address". • Received error codes are displayed such as "Decimal[Hex]".

Display Examples of Error Messages

"RHAA035: PLC1: Error has been responded for device write command (Error Code: 2[02H])"

NOTE

- Please refer to the manual of the External Device for more detail of received error codes.
- Please refer to "When an error message is displayed (Error Code List)" of "Maintenance/Troubleshooting manual" for cross-driver error message.

■ Error Codes Specific to the External Device

Error codes specific to the External Device are shown below.

Error Code	Description
RHxx128	Checksum does not match the packet actually received.
RHxx129	The MODBUS slave driver cannot be shared between COM1 and COM2.
RHxx130	The MODBUS slave driver cannot be used with the driver for COM%d.

9 Command Format

This driver supports the commands below.

Command	Function code		Minimum Points	Maximum Points	Device
Bit Block Read	Read Coil Status	0x01	16 Bits	2000 Bits	Coil
	Read Input Status	0x02			Discrete Input
Word Block Read	Read Holding Register	0x03	1 Word	125 Words	Holding Register
	Read Input Register	0x04			Input Register
Bit Block Write	Force Single Coil	0x05	1 Bit	1 Bit	Coil
	Force Multiple Coils	0x0F	1 Bit	800 Bits	
Word Block Write	Preset Single Register	0x06	1 Word	1 Word	Holding Register
	Preset Multiple Registers	0x10	1 Word	100 Words	
Diagnostics ^{*1 *2}	Preset Loop Back	0x08	-	-	-

*1 Diagnostics command is supported by the driver of which version is V1.12.02 or later.

*2 Diagnostics command is only supported by serial communication.