



Series 90-30/70 SNP Driver

1	System Configuration.....	3
2	Selection of External Device	5
3	Example of Communication Setting	6
4	Setup Items	10
5	Cable Diagram	14
6	Supported Device.....	20
7	Device Code and Address Code.....	21
8	Error Messages.....	22

Introduction

This manual describes how to connect the Display and the External Device (target PLC).

In this manual, the connection procedure will be described by following the below sections:

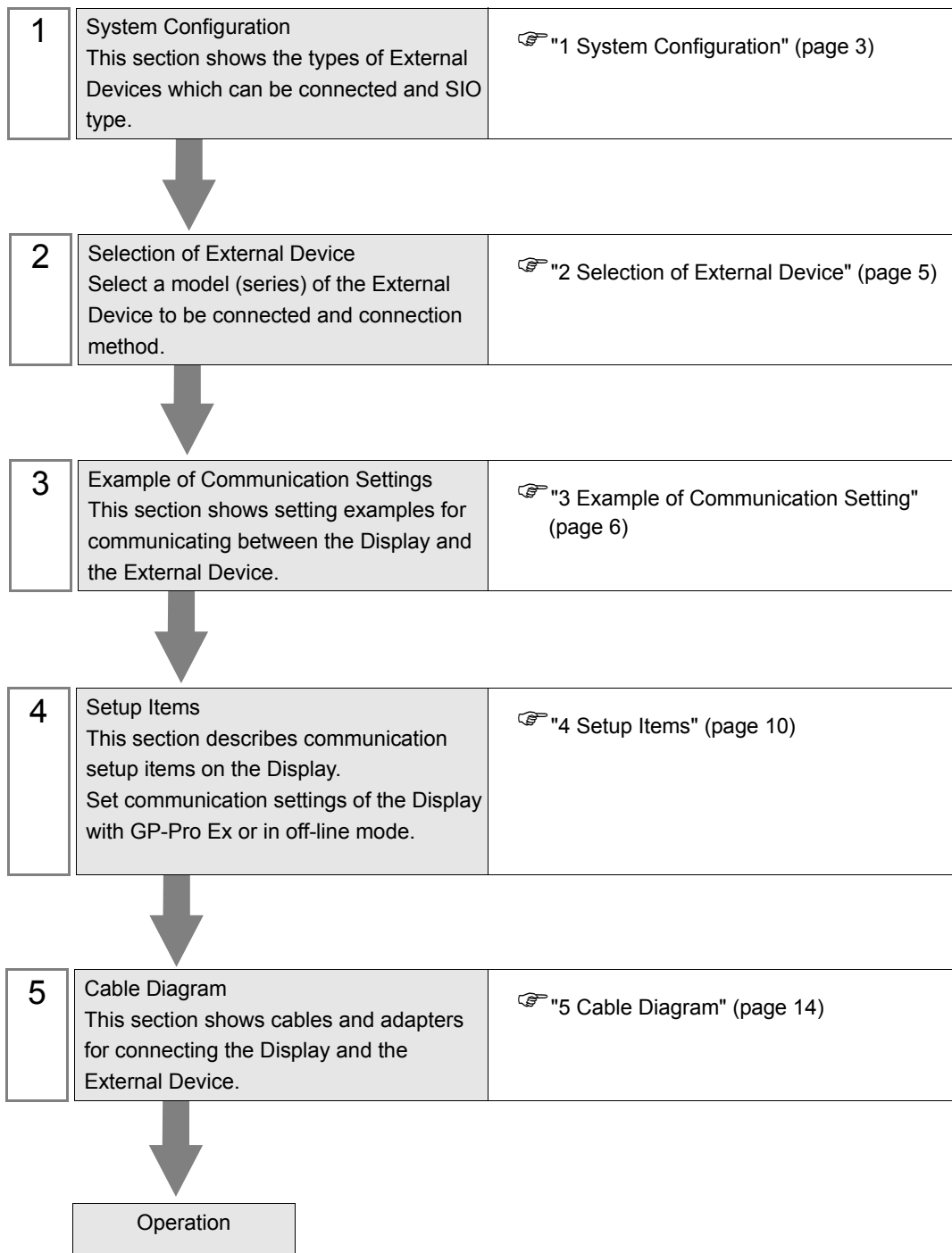

1 System Configuration

The system configuration in the case when the External Device of GE Fanuc Automation and the Display are connected is shown.

Series	CPU	Link I/F	SIO Type	Setting Example	Cable Diagram
Series 90-30	IC693CPU311 IC693CPU313 IC693CPU321 IC693CPU323 IC693CPU331 IC693CPU340 IC693CPU341 IC693CPU350 IC693CPU351 IC693CPU352 IC693CPU360 IC693CPU363 IC693CPU364 IC693CPU374 IC693CSE311 IC693CSE313 IC693CSE323 IC693CSE331 IC693CSE340	SNP serial port on power supply unit	RS422/485 (4wire)	Setting Example 1 (page 6)	Cable Diagram 1 (page 15)
Series 90-70	IC697CPU731 IC697CPU771 IC697CPU772 IC697CPU780 IC697CPU781 IC697CPU782 IC697CPU788 IC697CPU789 IC697CPM790 IC697CPM915 IC697CPM925 IC697CPX722 IC697CPX782 IC697CPX928 IC697CPX935 IC697CGR772 IC697CGR935 IC697CSE784 IC697CSE924 IC697CSE925	SNP serial port on CPU	RS422/485 (4wire)	Setting Example 2 (page 8)	

■ Connection Configuration

Series 90-30: SNP Serial Port on the PLC power supply

Series 90-70: SNP Serial Port on the PLC CPU Unit

- 1:1 Connection



- 1:n Connection

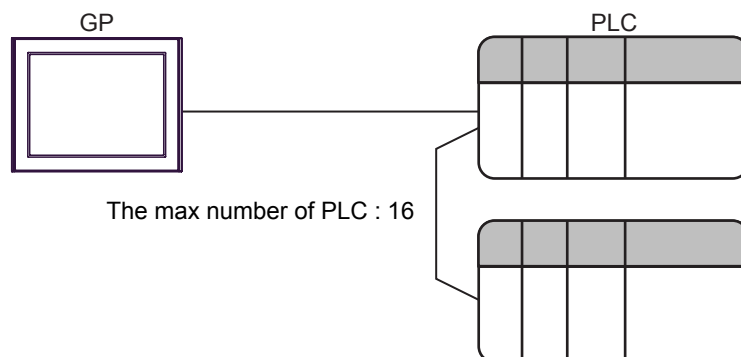

2 Selection of External Device

Select the External Device to be connected to the Display.

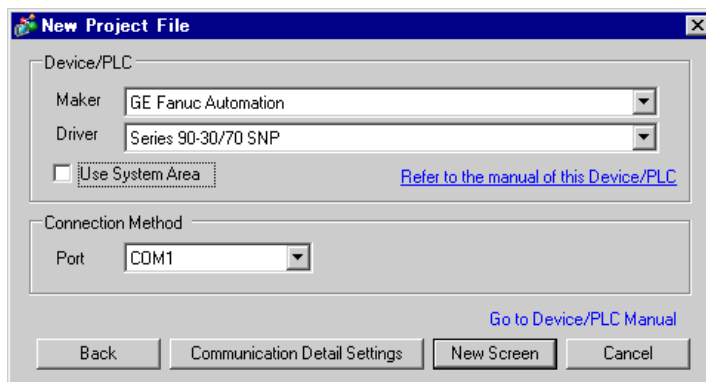

Setup Items	Setup Description
Maker	Select the maker of the External Device to be connected. Select "GE Fanuc Automation".
Driver	Select a model (series) of the External Device to be connected and connection method. Select "Series 90-30/70 SNP". Check the External Device which can be connected in "Series 90-30/70 SNP" in system configuration. ☞ "1 System Configuration" (page 3)
Use System Area	Check this option when you synchronize the system data area of Display and the device (memory) of External Device. When synchronized, you can use the ladder program of External Device to switch the display or display the window on the display. Cf. GP-Pro EX Reference Manual "Appendix 1.4 LS Area (only for direct access method)" This can be also set with GP-Pro EX or in off-line mode of Display. Cf. GP-Pro EX Reference Manual " 5.14.6 Setting Guide of [System Setting Window]■[Main Unit Settings] Settings Guide◆System Area Setting" Cf. Maintenance/Troubleshooting "2.14.1 Settings common to all Display models ◆System Area Settings"
Port	Select the Display port to be connected to the External Device.

3 Example of Communication Setting

Examples of communication settings of the Display and the External Device, recommended by Pro-face, are shown.

3.1 Setting Example 1

■ Settings of GP-Pro EX

◆ Communication Settings

To display the setting screen, select [Device/PLC Settings] from [System setting window] in workspace.

◆ Device Setting

To display the setting screen, click  ([Setting]) of External Device you want to set from [Device-Specific Settings] of [Device/PLC Settings].

When you connect multiple External Device, click  from [Device-Specific Settings] of [Device/PLC Settings] to add another External Device.

■ Settings of External Device

Use the ladder software for communication settings. (Check the operation in CIMPLICITY Machine Edition V4.50)

- 1 Select "Add Target" -> "GE Fanuc PLC" among "Project" of tool bar and select the series to be connected.
The selected series is added as "Target" in the project.
- 2 Allocate the power supply module and the CPU module in "Hardware Configuration" -> "Main Rack" of added Target.

NOTE • The Rack number and Slot number to allocate by environment using are different.
Check the environment, and allocate the Rack number and Slot number.

- 3 Double-click the CPU module, display the setting window.
- 4 Click the [Settings] tab and set the communication settings.
- 5 Forward the communication settings to the external device and spend a power supply of the external device again.

◆ Setup Items

Setup Items	Setup Description
Data Rate [bps]	19200
Parity	Odd
Stop Bits	1
SNP ID	1

◆ Notes

- Please refer to the manual of the ladder software for more detail on other setting description.

3.2 Setting Example 2

■ Settings of GP-Pro EX

◆ Communication Settings

To display the setting screen, select [Device/PLC Settings] from [System setting window] in workspace.

◆ Device Setting

To display the setting screen, click  ([Setting]) of External Device you want to set from [Device-Specific Settings] of [Device/PLC Settings].

When you connect multiple External Device, click  from [Device-Specific Settings] of [Device/PLC Settings] to add another External Device.

■ Settings of External Device

Use the ladder software for communication settings. (Check the operation in CIMPLICITY Machine Edition V4.50)

- 1 Select "Add Target" -> "GE Fanuc PLC" among "Project" of tool bar and select the series to be connected.
The selected series is added as "Target" in the project.
- 2 Allocate the power supply module and the CPU module in "Hardware Configuration" -> "Main Rack" of added Target.

NOTE • The Rack number and Slot number to allocate by environment using are different.
Check the environment, and allocate the Rack number and Slot number.

- 3 Double-click the CPU module, display the setting window.
- 4 Click the [Settings] tab and set the communication settings.
- 5 Forward the communication settings to the external device and spend a power supply of the external device again.

◆ Setup Items

Setup Items	Setup Description
Data Rate [bps]	19200
Data Bits	8
Parity	Odd
Stop Bits	1
SNP ID	1

◆ Notes

Please refer to the manual of the ladder software for more detail on other setting description.

4 Setup Items

Set communication settings of the Display with GP-Pro EX or in off-line mode of the Display.

The setting of each parameter must be identical to that of External Device.

☞ "3 Example of Communication Setting" (page 6)

4.1 Setup Items in GP-Pro EX

■ Communication Settings

To display the setting screen, select [Device/PLC Settings] from [System setting window] in workspace.

Setup Items	Setup Description
SIO Type	Display the SIO type to communicate with the External Device.
Speed	Select speed between the External Device and the Display.
Data Length	Display data length.
Parity	Select how to check parity.
Stop Bit	Select stop bit length.
Flow Control	Display the communication control method to prevent overflow of transmission and reception data.
Timeout	Use an integer from 1 to 127 to enter the time (s) for which the Display waits for the response from the External Device.
Retry	In case of no response from the External Device, use an integer from 0 to 255 to enter how many times the Display retransmits the command.
Wait To Send	Use an integer from 0 to 255 to enter standby time (ms) for the Display from receiving packets to transmitting next commands.

◆ Device Setting

To display the setting screen, click  ([Setting]) of External Device you want to set from [Device-Specific Settings] of [Device/PLC Settings].

When you connect multiple External Device, click  from [Device-Specific Settings] of [Device/PLC Settings] to add another External Device.

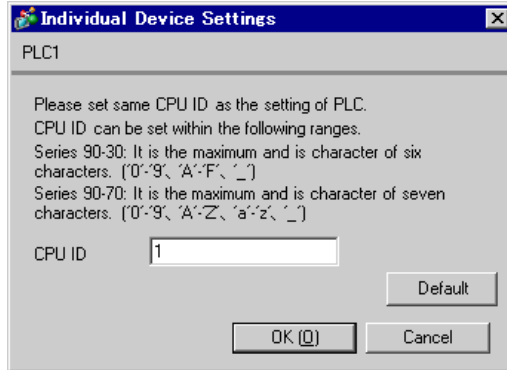

Setup Items	Setup Description
CPU ID	Set the CPU ID of PLC. Please set same CPU ID as the setting of PLC. CPU ID can be set within the following ranges. Series 90-30: It is the maximum and is character of six characters. ['0'-'9', 'A'-'F', '_'] Series 90-70: It is the maximum and is character of seven characters. ['0'-'9', 'A'-'Z', 'a'-'z', '_']

4.2 Setup Items in Off-Line Mode

- NOTE** • Please refer to Maintenance/Troubleshooting for more information on how to enter off-line mode or about operation.
Cf. Maintenance/Troubleshooting "2.2 Offline Mode"

◆ Communication Settings

To display the setting screen, touch [Device/PLC Settings] from [Peripheral Settings] in off-line mode. Touch the External Device you want to set from the displayed list.

Comm.	Device	Option		
Series 90-30/70 SNP		[COM1]	Page 1/1	
SIO Type	RS422/485(4wire)			
Speed	19200			
Data Length	8			
Parity	<input type="radio"/> NONE <input type="radio"/> EVEN <input checked="" type="radio"/> ODD			
Stop Bit	<input checked="" type="radio"/> 1 <input type="radio"/> 2			
Flow Control	NONE			
Timeout(s)	3			
Retry	2			
Wait To Send(ms)	0			
Exit		Back		2006/02/28 17:38:06

Setup Items	Setup Description
SIO Type	Display the SIO type to communicate with the External Device.
Speed	Select speed between the External Device and the Display.
Data Length	Display data length.
Parity	Select how to check parity.
Stop Bit	Select stop bit length.
Flow Control	Display the communication control method to prevent overflow of transmission and reception data.
Timeout	Use an integer from 1 to 127 to enter the time (s) for which the Display waits for the response from the External Device.
Retry	In case of no response from the External Device, use an integer from 0 to 255 to enter how many times the Display retransmits the command.
Wait To Send	Use an integer from 0 to 255 to enter standby time (ms) for the Display from receiving packets to transmitting next commands.

◆ Device Setting

To display the setting screen, touch [Device/PLC Settings] from [Peripheral Settings]. Touch the External Device you want to set from the displayed list, and touch [Device]..

Comm.	Device	Option		
Series 90-30/70 SNP		[COM1]	Page 1/1	
Device/PLC Name	PLC1			▼
CPU ID	1			
	Exit		Back	2006/02/20 17:18:09

Setup Items	Setup Description
Device/PLC Name	Select the External Device for device setting. Device name is a title of External Device set with GP-Pro EX.(Initial value [PLC1])
CPU ID	Set the CPU ID of PLC. Please set same CPU ID as the setting of PLC. CPU ID can be set within the following ranges. Series 90-30: It is the maximum and is character of six characters. ['0'-'9', 'A'-'F', '_'] Series 90-70: It is the maximum and is character of seven characters. ['0'-'9', 'A'-'Z', 'a'-'z', '_']

5 Cable Diagram

The cable diagram shown below may be different from the cable diagram recommended by Schneider Electric Industries. Please be assured there is no operational problem in applying the cable diagram shown in this manual.

- The FG pin of the External Device body must be D-class grounded. Please refer to the manual of the External Device for more details.
- SG and FG are connected inside the Display. When connecting SG to the External Device, design the system not to form short-circuit loop.
- Connect the isolation unit, when communication is not stabilized under the influence of a noise etc..
- When connecting to the COM3 of PS-3700A (Pentium®4-M) with External Device, it is necessary to set up the SIO type of COM3 with a Dip switch. Please refer to the manual of PS-3700A (Pentium®4-M) for details.

Dip switch setting: RS-422/485 (4 wire)

Dip switch	Setting	Description
1	OFF	Reserve (always OFF)
2	ON	SIO type of COM3: RS-422/485
3	ON	
4	OFF	Output mode of TX data: Always output
5	OFF	Terminal resistance insertion to TX (220Ω): None
6	OFF	Terminal resistance insertion to RX (220Ω): None
7	OFF	Short-circuit of TXA and RXA: Does not Exist
8	OFF	Short-circuit of TXB and RXB: Does not Exist
9	OFF	Auto Detection: Disable
10	OFF	

Cable Diagram 1

Display (Connection Port)	Cable		Notes
GP* ¹ (COM1) AGP-3302B (COM2) IPC* ² (COM3)	A	COM port conversion adapter by Pro-face CA3-ADPCOM-01 + Terminal block conversion adapter by Pro-face CA3-ADPTRM-01 + Your own cable	The cable length must be 1000m or less.
	B	Your own cable	
GP* ³ (COM2)	C	Online adapter by Pro-face CA4-ADPONL-01 + Terminal block conversion adapter by Pro-face CA3-ADPTRM-01 + Your own cable	
	D	Online adapter by Pro-face CA4-ADPONL-01 + Your own cable	

*1 All GP models except AGP-3302B

*2 Only COM3 of PS -3700A (Pentium®4-M) can be used. When use the COM3, set the SIO type of COM3 with Dip switch.

 Dip switch setting: RS-422/485 (4 wire) (page 14)

*3 All GP models except GP-3200 series and AGP-3302B

A) When using the COM port conversion adapter (CA3-ADPCOM-01), the terminal block conversion adapter (CA3-ADPTRM-01) by Pro-face and your own cable

- 1:1 Connection

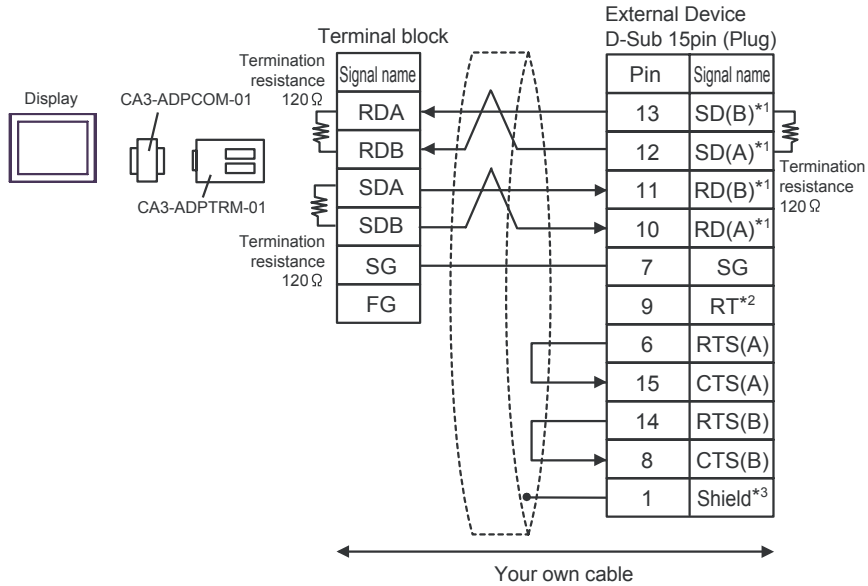

- 1:n Connection

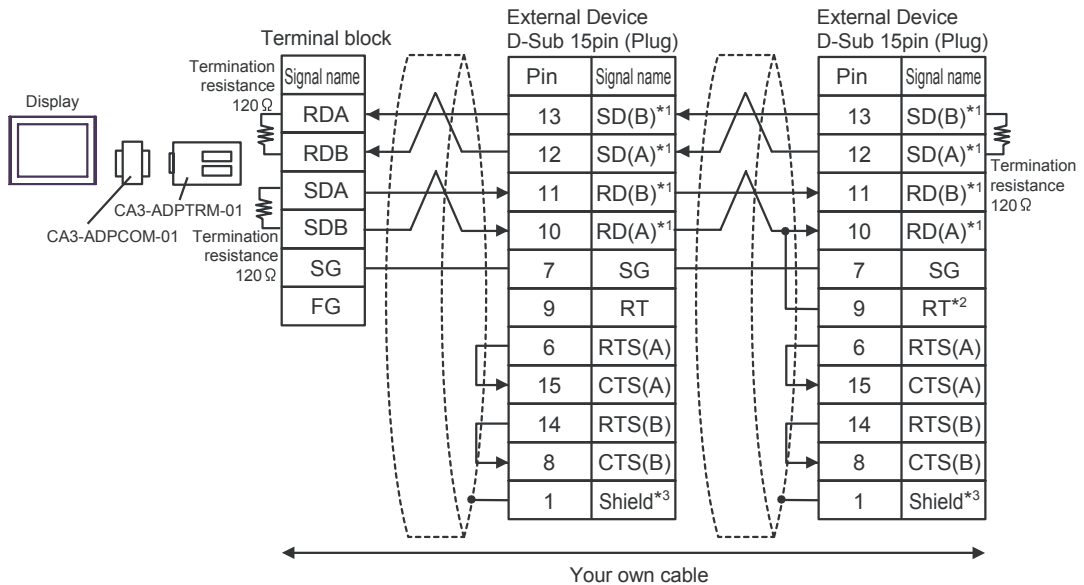

- *1: Notation of RD(A), RD(B), SD(A) and SD(B) are different by the external device. Please refer to the manual of the external device. In addition, please warn the naming of A class and B class is reversed to the display with the external device.
- *2: Insert the termination resistance of the external device side. The 120Ω termination resistance is inserted between RDA - RDB by connecting the 9th pin to the 10th pin of serial interface at the external device side. But termination resistance is inserted in CPU731 and CPU771 by connecting the 9th pin to the 11th pin.
- *3: FG of the external device ground the D class grounding. In addition, FG connection to a shield line select the external device side, either display side by location environment.

B) When using your own cable

- 1:1 Connection

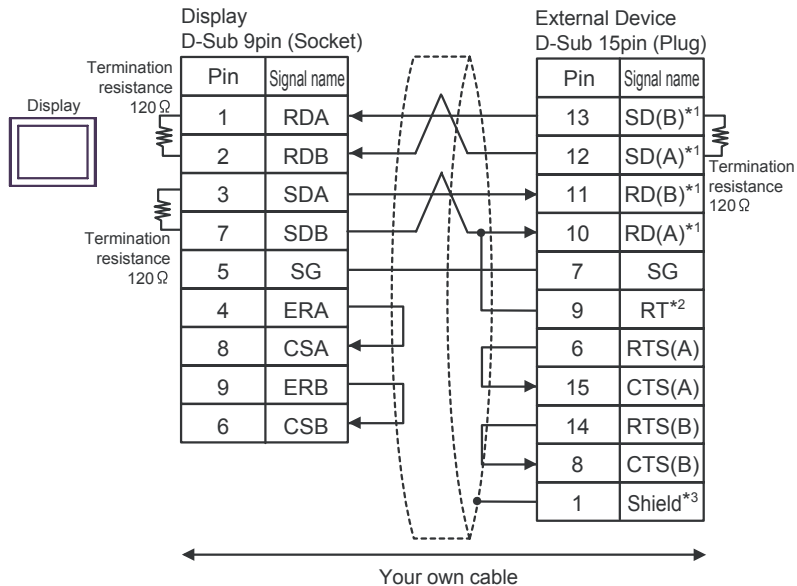

- 1:n Connection

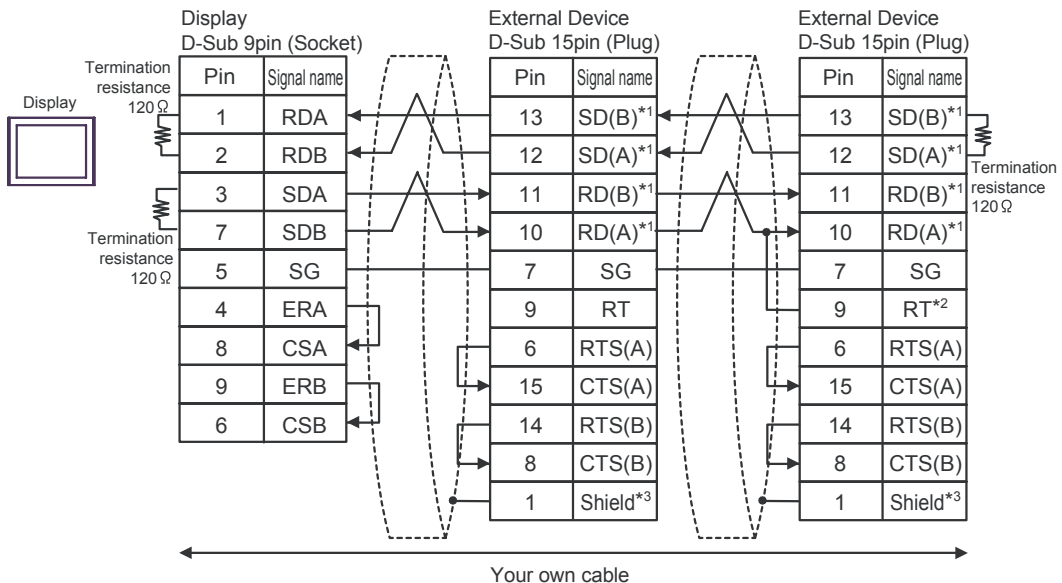

*1: Notation of RD(A), RD(B), SD(A) and SD(B) are different by the external device.

Please refer to the manual of the external device.

In addition, please warn the naming of A class and B class is reversed to the display with the external device.

*2: Insert the termination resistance of the external device side. The 120 Ω termination resistance is inserted between RDA - RDB by connecting the 9th pin to the 10th pin of serial interface at the external device side. But termination resistance is inserted in CPU731 and CPU771 by connecting the 9th pin to the 11th pin.

*3: FG of the external device ground the D class grounding. In addition, FG connection to a shield line select the external device side, either display side by location environment.

C) When using the online adapter (CA4-ADPONL-01), the terminal block conversion adapter (CA3-ADPTRM-01) by Pro-face and your own cable

- 1:1 Connection

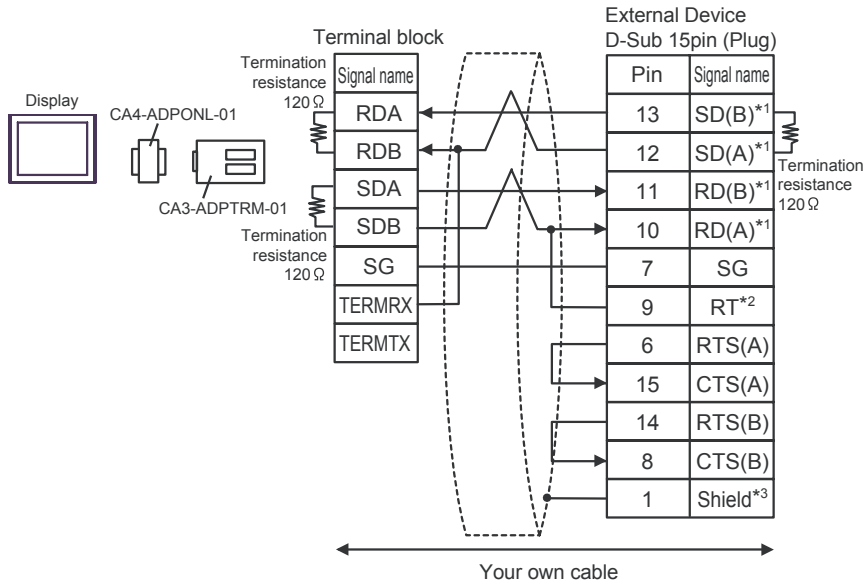

- 1:n Connection

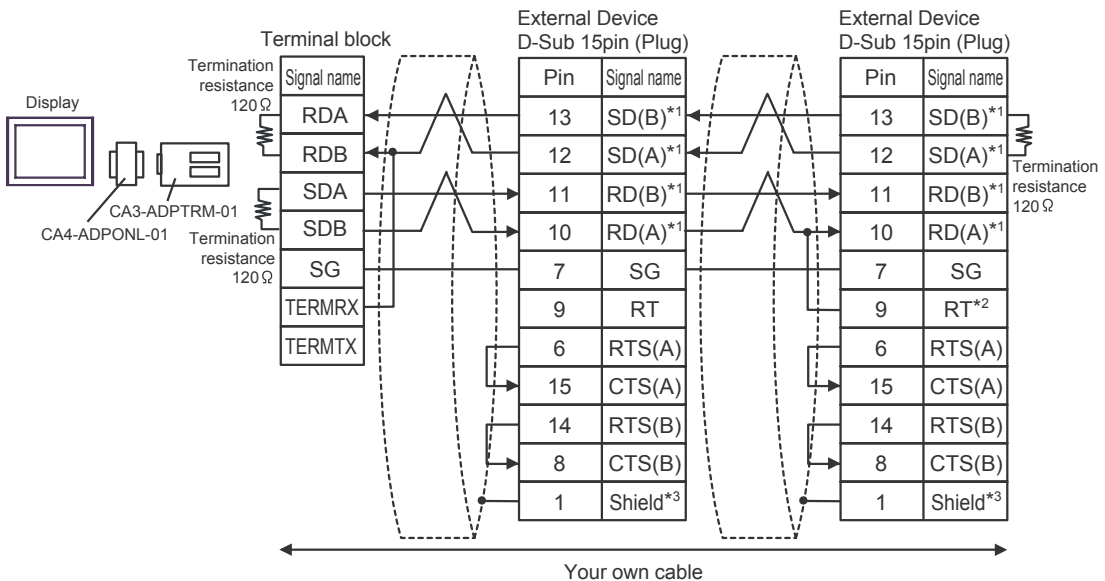

*1: Notation of RD(A), RD(B), SD(A) and SD(B) are different by the external device.

Please refer to the manual of the external device.

In addition, please warn the naming of A class and B class is reversed to the display with the external device.

*2: Insert the termination resistance of the external device side. The 120Ω termination resistance is inserted between RDA - RDB by connecting the 9th pin to the 10th pin of serial interface at the external device side. But termination resistance is inserted in CPU731 and CPU771 by connecting the 9th pin to the 11th pin.

*3: FG of the external device ground the D class grounding. In addition, FG connection to a shield line select the external device side, either display side by location environment.

D) When using the online adapter (CA4-ADPONL-01) by Pro-face and your own cable

• 1:1 Connection

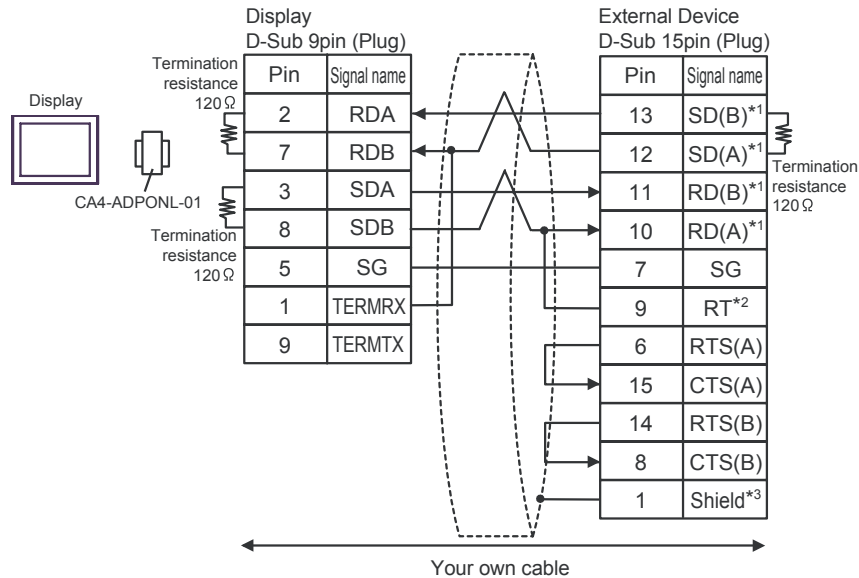

• 1:n Connection

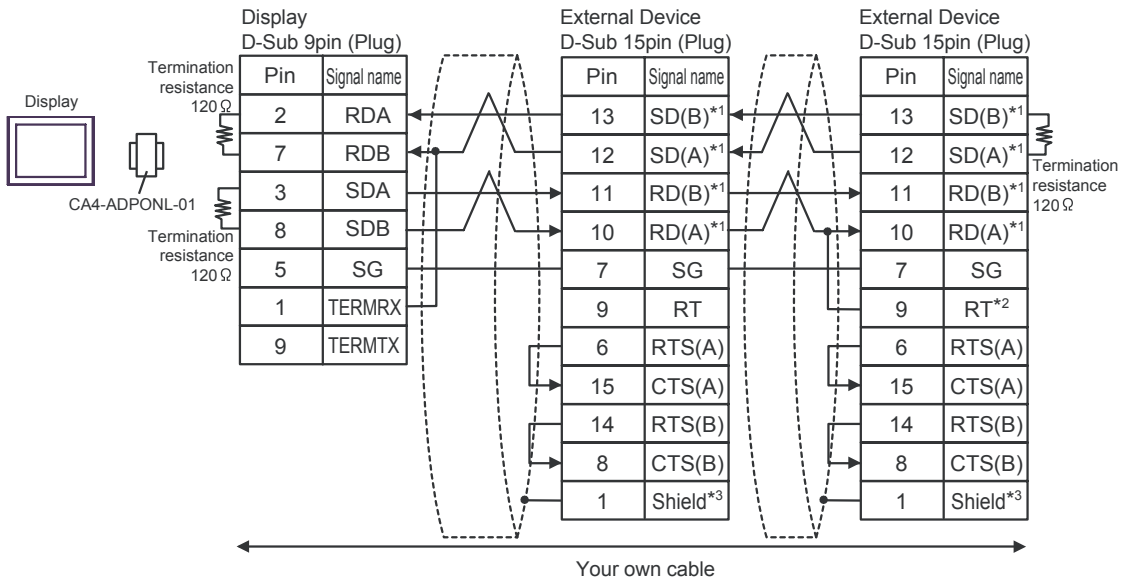

*1: Notation of RD(A), RD(B), SD(A) and SD(B) are different by the external device.

Please refer to the manual of the external device.

In addition, please warn the naming of A class and B class is reversed to the display with the external device.







*2: Insert the termination resistance of the external device side. The 120 Ω termination resistance is inserted between RDA - RDB by connecting the 9th pin to the 10th pin of serial interface at the external device side. But termination resistance is inserted in CPU731 and CPU771 by connecting the 9th pin to the 11th pin.

*3: FG of the external device ground the D class grounding. In addition, FG connection to a shield line select the external device side, either display side by location environment.

6 Supported Device

Range of supported device address is shown in the table below. Please note that the actually supported range of the devices varies depending on the External Device to be used. Please check the actual range in the manual of your connecting equipment.

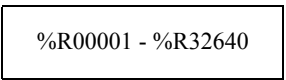
 This address can be specified as system data area.

Device	Bit Address	Word Address	32 bits	Notes
Discrete inputs	%I00001 - %I12288	%I00001 - %I12273		
Discrete outputs	%Q00001 - %Q12288	%Q00001 - %Q12273		
Discrete Globals	%G00001 - %G07680	%G00001 - %G07665		
Internal coils	%M00001 - %M12288	%M00001 - %M12273		
Temporary coils	%T00001 - %T00256	%T00001 - %T00241		
System status references	%S00001 - %S00128	%S00001 - %S00113		 *1
	%SA00001 - %SA00128	%SA00001 - %SA00113		
	%SB00001 - %SB00128	%SB00001 - %SB00113		
	%SC00001 - %SC00128	%SC00001 - %SC00113		
System register references	-----	 %R00001 - %R32640		
Analog inputs	-----	%AI00001 - %AI32640		
Analog outputs	-----	%AQ00001 - %AQ32640		

*1 Write disable

NOTE

- Please refer to the GP-Pro EX Reference Manual for system data area.
Cf. GP-Pro EX Reference Manual "Appendix 1.4 LS Area (only for direct access method)"
- Please refer to the precautions on manual notation for icons in the table.
 "Manual Symbols and Terminology"

7 Device Code and Address Code

Use device code and address code when you select "Device Type & Address" for the address type in data displays.

Device	Device Name	Device Code (HEX)	Address Code
Discrete inputs	%I	0080	(Word address - 1) / 16
Discrete outputs	%Q	0081	(Word address - 1) / 16
Discrete Globals	%M	0083	(Word address - 1) / 16
Internal coils	%G	0082	(Word address - 1) / 16
Temporary coils	%T	0084	(Word address - 1) / 16
System status references	%SA	0086	(Word address - 1) / 16
	%SB	0087	(Word address - 1) / 16
	%SC	0088	(Word address - 1) / 16
	%S	0085	(Word address - 1) / 16
System register references	%R	0000	Word address - 1
Analog inputs	%AI	0001	Word address - 1
Analog outputs	%AQ	0002	Word address - 1

8 Error Messages

Error messages are displayed on the screen of Display as follows: "No. : Device Name: Error Message (Error Occurrence Area)". Each description is shown below.

Item	Description
No.	Error No.
Device Name	Name of External Device where error occurs. Device name is a title of External Device set with GP-Pro EX. (Initial value [PLC1])
Error Message	Displays messages related to the error which occurs.
Error Occurrence Area	Displays IP address or device address of External Device where error occurs, or error codes received from External Device. NOTE <ul style="list-style-type: none"> • IP address is displayed such as "IP address (Decimal): MAC address (Hex)". • Device address is displayed such as "Address: Device address". • Received error codes are displayed such as "Decimal [Hex]".

Display Examples of Error Messages

"RHAA035: PLC1: Error has been responded for device write command (Error Code: 2 [02H])"

NOTE

- Please refer to the manual of External Device for more detail of received error codes.
- Please refer to "When an error message is displayed (Error code list)" of "Maintenance/Troubleshooting" for a common error message to the driver.

■ Error Code Peculiar to External Device

The error code characteristic of the external device is displayed in 2 Byte of "Major Error Status Code (1 Byte)" and "Minor Error Status Code (1 Byte)".

When received the error code from the external device, add to the below message. "Major Error Status Code" is displayed continuously "Major" and "Minor Error Status Code" is displayed continuously "Minor".

For details of the error code, please refer to the manual of the external device.

The error code peculiar to the external device is as follows.

Message ID	Error Message	Description
RHxx128	(Node Name): Error has been responded for initial communication command (Major:[%02Xh], Minor:[%02Xh])	Display the error message, when the error occurred by the reading demand.
RHxx129	(Node Name): Error has been responded for device read command (Major:[%02Xh], Minor:[%02Xh])	Display the error message, when the error occurred by the reading demand.
RHxx130	(Node Name): Error has been responded for device write command (Major:[%02Xh], Minor:[%02Xh])	Display the error message, when the error occurred by the write demand.
RHxx131	(Node Name): Error has been responded for device write command (Major:[%02Xh], Minor:[%02Xh] There are read only devises)	Display the error message, when write for the read only device.

